

1
2
3
4
5
6
7
8
9
10
11
12
13
14
15
16
17
18
19
20
21
22
23
24
25
26
27
28

BEFORE THE PUBLIC UTILITIES COMMISSION OF NEVADA

oo0oo

In the Matter of:

Docket No. 24-_____

Application of Great Basin Water Co., Pahrump, Spring Creek, Cold Springs, Pahrump, and Spanish Springs Divisions for Approval of its 2024 Integrated Resource Plan and to designate certain system improvement projects as eligible projects for which a system improvement rate may be established, and for relief properly related thereto.

VOLUME 16 OF 18

Document Description

Page No.

Appendix M, Part 3

2

- C. Clean up remove all excess soil, concrete, etc. from the premises. Leave job site in a neat and clean conditions.

3.015 PROTECTION AND RESTORATION OF EXISTING IMPROVEMENTS

- A. Protect all trees, plants and lawns that are not specified or shown on the Drawings to be removed for the performance of the Work, from injury or damage resulting from the construction operations.
- B. Signs, trees, plants and lawns which are removed, injured or damaged by the Contractor's operations shall be replaced or restored to their former state, or better, at the Contractor's expense.

END OF SECTION

SECTION 02340

BORING AND JACKING

PART 1 GENERAL

1.01 WORK OF THIS SECTION

- A. The Work of this Section includes providing bored or jacked steel casing and carrier piping installation within the steel casing, complete and in place. The carrier pipe shall be properly installed and supported within the casing. The casing shall be sealed at both ends.

1.02 RELATED SECTIONS

- A. The Work of the following Sections also apply to the Work of this Section. Other Sections, not referenced below, shall also apply to the extent required for proper performance of this Work.
 - 1. Section 02200 Earthwork
 - 2. Section 02401 Sanitary Sewer Pipe
 - 3. Section 02625 Pressure Piping, Valves and Fittings

1.03 REFERENCE SPECIFICATIONS AND STANDARDS

- A. Except as otherwise indicated in this Section, the CONTRACTOR shall comply with the latest adopted edition of the Standard Specifications for Public Works Construction (Orange Book).
- B. Except as otherwise indicated, the current editions of the following apply to the Work of this Section:
 - 1. ASTM A 283 Specification for Low and Intermediate Tensile Strength Carbon Steel Plates
 - 2. ANSI/AWS D1.1 Structural Welding Code
 - 3. ANSI/AWWA C200 Steel Water Pipe 6 Inches and Larger

1.04 CONTRACTOR SUBMITTALS

- A. Shop Drawings: The CONTRACTOR shall submit shop drawings of pipe casing in accordance with the project requirements and the following. Submittals shall include the following supplemental requirements as applicable:
 - 1. Casing installation schedules, which include schedules of excavation, pipeline installation, pipeline support, and backfill operations.
 - 2. Material list including diameter, thickness, and class of steel casing, any lubricant proposed outside the casing, and pipeline supports.

3. Detailed locations and sizes of all boring or jacking and receiving pits.
 4. Permits associated with the boring or jacking operations.
- B. Certifications: The CONTRACTOR shall furnish a certified affidavit of compliance for all pipe and other products or materials furnished under this Section, including physical and chemical properties of all steel.
- C. All expenses incurred in making samples for certification of tests shall be borne by the CONTRACTOR.

1.05 QUALITY ASSURANCE

- A. All boring or jacking operations shall be done by a qualified contractor with at least 5 years experience involving work of a similar nature.
- B. The CONTRACTOR shall furnish the OWNER a minimum of 3 days' advance notice of the start of an excavation or boring operations.
- C. All Work shall be performed in the presence of the OWNER, unless the OWNER has granted prior approval to perform such work in its absence.
- D. Welding Requirements: All welding procedures used to fabricate steel casings shall be prequalified under the provisions of ANSI/AWS D1.1. Welding procedures shall be required for, but not necessarily limited to, longitudinal and girth or special welds for pipe cylinders, casing joint welds, reinforcing plates and grout coupling connections.
- E. Welders' Qualifications: All welding shall be done by skilled welders, welding operators, and tackers who have had adequate experience in the type of materials to be used. Welders shall be qualified under the provisions of ANSI/AWS D1.1 by an independent local, approved testing agency not more than 6 months prior to commencing work on the casing or pipeline. Machines and electrodes similar to those used in the Work shall be used in qualification tests. Furnish all material and bear the expense of qualifying welders.

1.06 SAFETY

- A. The CONTRACTOR shall provide flagmen, barricades, lights, warning signs, ventilation, air quality monitoring, and other safety devices and equipment as may be required to ensure the safety of all people who may enter the area. The CONTRACTOR shall establish a procedure to log all persons into and out of the bore shaft and shall take necessary steps to prevent unauthorized entry.
- B. All boring and jacking work shall be performed in accordance with all applicable safety provisions in the Reference Specifications and Standards identified herein.

PART 2 PRODUCTS

2.01 GENERAL

- A. Steel casings shall be welded steel pipe of the diameters and plate thicknesses indicated. The steel pipe casings shall conform to ANSI/AWWA C200, subject to the following supplemental requirements. The casing shall be furnished complete with welded joint ends and pressure grout couplings as indicated. The CONTRACTOR may select a greater diameter or thickness for the method of work and loadings involved, site conditions, and possible interferences at no additional cost to the OWNER.

2.02 MATERIALS

- A. Steel Casing: The steel casing pipe shall be in accordance with ASTM A 283, Grade C, unless indicated otherwise. The minimum casing inside diameter shall be at least 4 inches larger than maximum outside diameter of the carrier pipe. The casing wall thickness shall be designed to accommodate the maximum jacking load allowed, as well as expected earth and live loads. Thickness shall be no less than 3/8 inch and the CONTRACTOR shall be fully responsible for the sufficiency of the casing provided. Casing section joints shall be of the interlocking type or butt-welded, lap welded, or welded using butt straps in the field. Each end of the casing for butt-welding shall be prepared by providing 1/4-inch by 45-degree chamfer on the outside edges.
- B. Carrier Pipe Support: The CONTRACTOR shall provide Calipco Model PX or approved equal casing spacers to support the carrier pipe within the casing, to prevent the carrier pipe from floating, and to electrically insulate the carrier pipe from the casing. Skids or spacers shall be designed and spaced to support the carrier pipe when full, with no water in the annular space. The skids or casing spacer risers on the underside of the carrier pipe shall be high enough so that the carrier pipe shall clear the invert of the casing pipe by one inch minimum. There shall also be a maximum of one-inch clear space between the top of this top skid or riser and the crown of the casing.
- C. Casing End Seals: Seals shall be standard wrap around end seals, made of synthetic rubber, with self curing rubber sealing strips and provided with Type 316 stainless steel bands and clamps. End seals shall be manufactured by APS, Model AC or approved equal.

PART 3 EXECUTION

3.01 GENERAL

- A. The CONTRACTOR shall comply with the lawful requirements of the affected railway companies, Nevada DOT, public agencies, and owners of public utilities or other facilities respecting the safeguarding of traffic and improvements that might be endangered by the boring and jacking operations. The approach trenches in public streets will not be permitted to remain open for extended periods of time.
- B. If the CONTRACTOR is not ready to place the pipe in the casing at the time of completion of boring and jacking operations, the ends shall be bulkheaded, and the approach trenches in public streets shall be backfilled, temporary surfacing placed thereon, and the affected portion of the street reopened to traffic.

- C. The CONTRACTOR shall be responsible for maintaining the specified line and grade, and for preventing settlement of overlying structures, or other damage due to the boring and jacking operations.
- D. Unless soil borings in the immediate vicinity of the jacking location are made available by the OWNER, CONTRACTOR shall investigate the existing soils and subsurface conditions so the appropriate equipment is provided to counter conditions which can cause delay such as groundwater, running sand, boulders, etc.
- E. The CONTRACTOR shall obtain all necessary permits from governing agencies having jurisdiction over the location of the boring and jacking location and furnish two copies to the OWNER before the start of excavation.
- F. The CONTRACTOR shall abide by all permit conditions.
- G. The CONTRACTOR shall obtain insurance required under the terms of the permit.

3.02 INSTALLATION OF CASING

- A. Installation: The installation of the casing shall be in accordance with Orange Book and subject to the approval of the agency having jurisdiction over the area containing the boring or jacking operations. The CONTRACTOR shall obtain all necessary permits and furnish two copies to the OWNER before the start of excavation.
- B. Potholing: The CONTRACTOR shall pothole all existing utilities within and adjacent to the proposed location of the bored and jacked casing prior to excavating the boring/jacking and receiving pits. The CONTRACTOR shall coordinate all potholing with the respective utility owners.
- C. Jacking Head: A steel jacking head shall be fitted to the lead section of the casing in such a manner that it extends around the entire outer surface of the steel casing and projects at least 18 inches beyond the driving end of the casing. The jacking head shall not protrude more than ½-inch outside of the outer casing surface. The head shall be securely anchored to prevent any wobble or alignment variation during the boring or jacking operations. To minimize voids outside the casing, excavation shall be entirely within the jacking head and not in advance of the head. Excavated materials shall be removed from the casing as the boring or jacking operation progresses and accumulation of excavated materials within the casing shall not be permitted.
- D. Jacking Pit: The excavations for the boring or jacking operations shall be adequately shored to safeguard existing substructures and surface improvements and to ensure against ground movement in the vicinity of the jack supports. Heavy guide timber, structural steel, or concrete cradles of sufficient length shall be provided to assure accurate control of boring or jacking alignment. Adequate space shall be provided within the excavation to permit the insertion of the lengths of casing to be bored or jacked. Timbers and structural steel sections shall be anchored to ensure action of the jacks in line with the axis of the casing. A bearing block, consisting of a timber or structural steel framework, shall be constructed between the jacks and the end of the casing to provide uniform end bearing over the perimeter of the casing and distribute the jacking pressure evenly.

- E. Control of Alignment and Grade: The CONTRACTOR shall control the application of the jacking pressure and excavation of materials ahead of the casing but within the jacking head as it advances to prevent the casing from becoming earthbound or deviating from the required line and grade. The CONTRACTOR shall restrict the excavation of the materials to the least clearance necessary to prevent binding in order to avoid loss of ground and consequent settlement or possible damage to overlying structures. Allowable grade deviations in horizontal and vertical alignments shall be no greater than 0.2 feet per 100 feet in any direction over the length of the jacking or boring to a maximum deviation of 0.5 feet. Final installation shall be without a sag in the pipe. A lubricant such as bentonite may be used to reduce the friction between the casing and the borehole after first reviewing the procedure with the OWNER. Survey control shall be provided by a Nevada licensed land surveyor who shall also monitor for any settlement over the casing. The CONTRACTOR shall provide two copies of the controls and monitoring record to the OWNER at completion.

3.03 INSTALLATION OF CARRIER PIPE

- A. Joints: All joints of the carrier pipe within the casing shall be restrained in accordance with the Specification Sections for the type of carrier pipe material installed.
- B. Carrier Pipe Support: The CONTRACTOR shall position casing spacers to prevent excessive sag, bending and shear stresses in the piping. A casing spacers or skids shall be placed within 6 inches of each end of the conductor casing. There shall be a minimum of two casing spacers installed on each section of pipe.
- C. Testing of the Carrier Pipe: Testing of the carrier pipe shall be completed in accordance with specification Section 02401 – Sanitary Sewer Pipe or Section 02625 – Pressure Pipe, Valves and Fittings.
- D. Installation of Conductor Casing End Seals: The CONTRACTOR shall secure the casing seals in place with stainless steel bands in accordance with the manufacturer’s recommended procedures. The installation shall be made watertight by bonding together the exposed overlapping surfaces with a permanent sealing adhesive.
- E. Closing of Pits: After jacking equipment and excavated materials from boring or jacking operations have been removed from the jacking pit, the CONTRACTOR shall prepare the bottom of the jacking pit as a pipe foundation. All loose and disturbed materials below pipe grade shall be removed to undisturbed earth and shall be filled and recompact in accordance with Specification Section 02200 - Earthwork.

END OF SECTION

SECTION 02401

SANITARY SEWER PIPE

PART 1 GENERAL

1.01 DESCRIPTION

- A. The WORK under this Section includes providing all labor, materials, tools and equipment necessary for furnishing and installing sanitary sewer pipe, in accordance with these Specifications and the Plans or established by the ENGINEER.
- B. This WORK includes furnishings and installing connecting bands, branch connections, elbows or other fittings, and all appurtenances required to complete the sanitary sewer.

1.02 SUBMITTALS

- A. Sanitary Sewer Pipe: Material certifications stating conformance with the requirements of this Section.
- B. Submittal shall be delivered to Engineer in accordance with Section 01300 - Submittals of the Technical Specifications.

1.03 REFERENCES

- A. ASTM D2680 Standard Specification for Acrylonitrile-Butadiene-Styrene (ABS) and Poly(Vinyl Chloride) (PVC) Composite Sewer Piping
- B. ASTM D2751 Standard Specification for Acrylonitrile-Butadiene-Styrene(ABS) Sewer Pipe and Fittings
- C. ASTM D3034 Standard Specification for Type PSM Poly(Vinyl Chloride) (PVC) Sewer Pipe and Fittings
- D. ASTM D3350 Standard Specification for Polyethylene Plastics Pipe and Fittings Materials
- E. ASTM F 679 Standard Specification for Poly(Vinyl Chloride) (PVC) Large-Diameter Plastic Gravity Sewer Pipe and Fittings
- F. ASTM F714 Standard Specification for Polyethylene (PE) Plastic Pipe (SDR-PR) Based on Outside Diameter
- G. ASTM D3212 Standard Specification for Joints for Drain and Sewer Plastic Pipes Using Flexible Elastomeric Seals
- H. Orange Book Standard Specifications for Public Works Construction, Regional Transportation Commission of Washoe County et al., 1996 Edition and current revisions.

PART 2 PRODUCTS

2.01 PVC SEWER PIPE

- A. PVC Sewer Pipe, four inches through 15 inches in diameter, inclusive, shall have a standard dimension ratio (SDR) of 35, and conform to ASTM D 3034. Before any PVC pipe is used on this project, the CONTRACTOR shall supply certifications, signed by an authorized agent of the seller or manufacturer, stating that the material has been sampled, tested, and inspected in accordance with ASTM D 3034.
- B. PVC Sewer Pipe greater than 15 inches in diameter shall conform to ASTM F 679. Before any PVC pipe is used, the CONTRACTOR shall supply certifications, signed by an authorized agent of the seller or manufacturer, stating that the material has been sampled, tested, and inspected in accordance with ASTM F 679.
- C. The pipe shall have integral wall bell and spigot joints conforming to ASTM D 3212. The bell shall consist of an integral wall section with a solid cross-section elastomeric ring, factory assembled, securely locked in place to prevent displacement.
- D. Flexible water-tight connections, approved by the ENGINEER, shall be used at PVC pipe connections to manholes and other rigid structures.

2.02 UNDERGROUND MARKING TAPE

- A. Underground marking tape shall be green, at least four (4) inches wide, four mil thick, polyethylene tape, with a metallic backing capable of being traced with locators. The tape shall have black letters with the following wording: "Caution: Sewer Line Buried Below" in letters a minimum 1-1/4" tall. The marking tape shall be installed 12 inches above the top of all sewer mains and services.

PART 3 EXECUTION

3.01 CONSTRUCTION

- A. Excavation, bedding, and backfill shall conform to the requirements of Section 02225 – Trench Excavation and Backfill. Underground marking tape shall be installed as shown on the plans.
- B. Sheeting and bracing required for trenches shall be removed to the elevation of the conduit, but no sheeting will be allowed to be pulled, removed, or disturbed below the conduit. Sheeting and bracing shall meet OSHA requirements.
- C. Before lowering into the trench, the pipe shall be inspected for defects. All cracked, chipped, or broken pipe shall be discarded. The ends and interior of the pipe shall be clean. Belled ends shall be laid upgrade. Handling of the pipe shall be accomplished in a manner that will not damage the pipe. The joint shall be made in the manner recommended by the manufacturer. Care shall be taken not to buckle or disturb previously laid pipe.

- D. Pipe shall be laid accurately to the staked line and grade. All service connections shall be installed as indicated on the Drawings. Where existing service sewers are to be connected, suitable fittings and adapters shall be provided by the CONTRACTOR.
- E. Pipe shall be cleaned of all foreign matter, and water shall be kept out of trenches until joints have been completed. When WORK is not in progress, open ends of pipe and fittings shall be securely closed to keep foreign matter and animals from entering.
- F. Each joint shall be inspected to ensure that it is properly made before backfilling is done. Care shall be taken to prevent any dirt or foreign matter from entering the open end of the pipe. Where it is necessary to cut pipe, such cuts shall be neatly made in an approved manner. The laid pipe shall be true to line and grade and, when completed, the sewer shall have a smooth and uniform invert. No section of gravity sewer, including service connections shall have an adverse grade which would pond water in the invert of the sewer.
- G. Connections to existing sewer mains, service connections, and manholes shall be made in such a manner so as to not damage the existing facility. Such connections shall be made so that no projections or rough surfaces occur within the pipe.
- H. If the CONTRACTOR believes that the WORK at the new location(s) will result in a substantive change, the CONTRACTOR shall notify the ENGINEER prior to beginning the changed WORK. The ENGINEER will evaluate the request and if the relocation is warranted, the change in WORK shall be authorized.
- I. Where gravity flow sanitary sewers cross above or less than 18 inches below waterlines, or approximately parallel water lines within ten feet horizontally, the sewer pipe shall meet the requirements Nevada Administrative Code sections 445A.6715 through 445A.67175.

3.02 TESTING

- A. Prior to testing all manholes, all sections of pipe shall be cleaned using an inflatable rubber ball of a size that will inflate to fit snugly into the pipe. The ball may, at the option of the CONTRACTOR, be used without a tag line; or a rope or cord may be fastened to the ball to enable the CONTRACTOR to know and control its position at all times. The ball shall be placed in the last clean out or manhole on the pipe to be cleaned, and water shall be introduced behind it. The ball shall pass through the pipe with only the force of the water impelling it. All debris flushed out ahead of the ball shall be removed at the first manhole where its presence is noted. In the event cemented or wedged debris, or a damaged pipe, stops the ball, the CONTRACTOR shall remove the obstruction and make any necessary repairs in a manner that is acceptable to the ENGINEER. Any alternate methods of cleaning sewers shall be submitted to the ENGINEER for approval, and shall not be used unless approved.
- B. Prior to testing, the sewer shall be complete with laterals, and trenches shall be fully backfilled and compacted to finish grade, or, if the sewer is under pavement, finish pavement subgrade.
- C. For WORK involving placement of new sanitary sewer collection systems, all sections of pipe shall be tested for leakage using the Exfiltration Test for either air or water as specified hereafter; or, at the sole direction of the ENGINEER, when the normal water table is above the sewer throughout the section under test, the ENGINEER may permit use of the Infiltration Test procedure specified hereafter. Where leakage is in excess of the specified

rate, the sewer shall be repaired by the CONTRACTOR as required to comply with the leakage test requirements. The ENGINEER may require the CONTRACTOR to repair obvious leaks even though the total length of the test section falls within the maximum allowable leakage for the test used.

- D. For WORK involving replacement of existing, active sanitary sewer collection systems, and the new system is not put into service during the same work shift, no Exfiltration/ or Infiltration Tests will be required.
- E. Defective pipe joints shall be repaired in a manner that the repaired pipe joint will have some flexibility and the effectiveness of the repair will not be affected by differential movement of the adjoining pipes. A Fernco Coupling as per the Standard Details, or approved equal, will be acceptable in making such repairs.
- F. The CONTRACTOR will make one complete TV inspection after all sewers have passed the specified watertightness test. All defects regarding sewer alignment and grade, damaged pipe, and visible leaks observed during this inspection, shall be corrected by the CONTRACTOR. The CONTRACTOR shall de-water the sewers as required for the performance of the TV inspection work by the ENGINEER. The CONTRACTOR shall be responsible for all costs associated with any TV inspection required following the initial TV inspection, if any defects were observed during this or any subsequent TV inspections.
- G. Pressure and leakage testing for the pressurized sewer force main shall be conducted in accordance with Section 02675.

3.03 FILTRATION TEST FOR GRAVITY SEWER PIPES (USING AIR)

- A. The CONTRACTOR shall furnish all facilities and personnel for conducting the test under the observation of the ENGINEER. The equipment and personnel shall be subject to the approval of the ENGINEER. Joints only may be tested in pipe 36 inches in diameter or larger, at the option of the CONTRACTOR.
- B. Immediately following the pipe cleaning, the pipe installation shall be tested with low pressure air. Air shall be slowly supplied to the plugged pipe installation until the internal air pressure reaches five pounds per square inch greater than the average back pressure of any ground water that may submerge the pipe. At least two minutes shall be allowed for temperature stabilization before proceeding further.
- C. The pipeline shall be considered acceptable when tested at an average pressure of four psi greater than the average pressure of any ground water that may submerge the pipe if the section under test does not lose air at a rate greater than 0.0030 cubic feet per minute per square foot of internal surface.
- D. The requirements of this Specification shall be considered satisfied if the time required for the pressure to decrease from 4.5 psi to 3.5 psi above average ground water pressure is greater than that shown on the following table:

**TIME FOR PRESSURE TO DROP FROM
4.5 TO 3.5 PSI ABOVE AVERAGE GROUND WATER PRESSURE**

Pipe Diameter	Minutes	Seconds
8"	3	57
10"	4	43
12"	5	40
15"	7	5
18"	8	30
24"	11	20
30"	14	10

E. For other sizes, determine test time using the following formula:

$$T = 28.33 D$$

Where T = time in seconds
D = pipe diameter in inches

- F. For pipes 36 inches in diameter, or larger, if individual joints are tested, they shall hold six psi air pressure over the average back pressure of any ground water for a minimum time of 15 seconds.
- G. Pressure gauges should be incremented in not more than one-half pound increments for accurate tests.
- H. Braces shall be required to hold plugs in place and to prevent the sudden release of the compressed air. Due to the large forces that could be exerted by an escaping plug during the testing of the pipe, no one shall be allowed in the manholes in which plugs have been placed while tests are being conducted. The CONTRACTOR's testing equipment shall have a pressure relief device that will prohibit the pressure in the pipeline from exceeding ten pounds per square inch.

3.04 EXFILTRATION TEST FOR GRAVITY SEWER PIPES (USING WATER)

A. Where groundwater is below the pipe to be tested, a minimum head of eight feet of water above the crown at the upper end of the test section shall be maintained for a period of four hours, during which time it will be presumed that full absorption of the pipe body has taken place, and thereafter for a further period of one hour for the actual test of leakage. During this one hour period, the measured loss shall not exceed the rate given below:

Type of Pipe	Allowable Exfiltration Rate
Ductile Iron	E = 0.00008 DL
PVC	E = 0.0004 DL

E = Allowable leakage in gallons per hour
D = Nominal inside diameter of pipe in inches
L = Length of pipe being tested in feet

B. Where groundwater is above any pipe to be tested, the minimum head of the test will be raised to provide an elevation head of eight feet above the groundwater.

C. The maximum length of sewer in any test section shall be 500 feet.

3.05 INFILTRATION TEST FOR GRAVITY SEWER PIPE

A. Infiltration testing may be allowed at the ENGINEER's option when the natural ground water table is above the crown of the higher end of the test section and the external water pressure exerted on the pipe is equivalent to the exfiltration test. The maximum allowable limit for infiltration shall be as determined by the formulas defined in the above section Exfiltration Test (Using Water).

END OF SECTION

SECTION 02601

MANHOLES

PART 1 GENERAL

1.01 GENERAL

- A. Except as otherwise permitted herein, manholes shall be constructed of precast, reinforced concrete sections on either precast or cast-in-place, reinforced concrete bases. Manholes shall conform to the size, shape, form and details shown on the Plans.

PART 2 PRODUCTS

2.01 PRECAST CONCRETE SECTIONS

- A. All precast cylinder units, precast concrete taper sections and precast base units shall meet the strength requirements for a Precast Reinforced Concrete Manhole Risers and Tops, ASTM C 478. Design and manufacture shall be based on H20 loading. Precast manholes shall be as manufactured by Jensen Precast Inc., or by an approved manufacturer. The Contractor shall submit shop drawings of the precast manhole units he proposes to use.
- B. All concrete manholes shall be inspected by an independent, certified testing laboratory, approved by the City, to establish the strength of the concrete and the adequacy of curing to certify the date that the manholes were cast and to confirm that the steel has been properly placed, all in accordance with the Plans and Specifications. The cost of these tests shall be included in the various unit price Contract Items and no special payment will be made therefore. This testing shall be performed by the laboratory at the contractor's manufacturing plant, prior to shipment.
- C. At least three cylinders shall be taken each day that manholes are cast, with batch samples to be designated by the laboratory representative. At least one set of cylinders shall be taken for each nine cubic yards of concrete used in the construction of the manhole sections. These samples shall be tested for strength. If the samples fail to meet minimum concrete strength requirements set forth in the Specifications, all manhole sections manufactured from the concrete from which the cylinders were made will be considered rejected.
- D. In addition, the Owner reserves the right to core manholes either at the site or point of delivery to validate strength of concrete and placement of steel. If cores fail to demonstrate the required strength or indicate incorrect placement of reinforcing steel, all sections not previously tested will be considered rejected until sufficient additional cores are tested, at the Contractor's expense, to substantiate conformance to these requirements.

2.02 CONCRETE (CAST-IN-PLACE BASES)

A. Curing

1. All precast concrete manhole sections shall be cured in accordance with any one of the methods specified in ASTM 478. The facilities for curing shall, however, be subject to the review and prior approval of the Engineer. No precast concrete manhole sections shall be delivered to the job site until the specified minimum comprehensive strength of 4,000 psi, as determined by crushing tests on cured concrete cylinders, has been obtained.
2. All cast-in-place concrete manhole bases shall be covered and protected from freezing temperatures.

B. Frames and Covers

1. Manhole frames and covers shall be of gray iron, shall meet the requirements ASTM A48-30 and shall conform to the details shown on the Plans.

C. Joint Sealing Compound

1. Precast manhole sections shall be jointed with a preformed joint sealing compound, manhole joint sealant by Jensen Precast Inc., or equivalent, applied in accordance with the manufacturer's instructions.

D. Drop Manhole

1. Drop manholes shall be constructed at the location and in conformance with the details shown on the Plans. Materials and construction of drop manholes shall conform in all respects to the applicable provisions of these Specifications for standard precast manholes (including frames and covers), with modifications for the addition of drop inlet pipe of the diameter noted on the Plans or these Specifications.
2. Drop connections shall be built along the line of the pipe at the points indicated on the Plans. They shall be of precast concrete construction conforming to the Specifications for precast concrete manhole construction.
3. Fittings for drop sewer connections shall be furnished and set in the manner shown on the Plans. In all drop sewer connections. The drop tee and other fittings shall be of polyvinyl chloride pipe encased in concrete as shown on the Plans.
4. The interior of the drop manhole shall be epoxy coated with three coats of a factory or field applied acrylic polymer-base concrete coating and sealant that is neither asphalt nor coal tar based. Acceptable coating is ConSeal CS-55, colors gray or black, as manufactured by Concrete Sealants, New Carlisle, Ohio or equal. The total dry film thickness shall be 3.5 mils. Coating shall be applied to the tongue and groove area of the manhole sections as well.

PART 3 EXECUTION

3.01 TRANSPORTATION AND DELIVERY

- A. Every precaution shall be taken to prevent injury to the precast manhole sections during the transportation and unloading of the sections. The precast sections shall be unloaded using skids, pipe hooks, rope slings, or suitable power equipment, if necessary, and the sections shall be under perfect control at all times. Under no conditions shall the precast sections be dropped, dumped or dragged.
- B. If any precast section is damaged in the process of transportation, or handling, such section shall be rejected and immediately removed from the site and replace at the Contractor's expense.

3.02 EXCAVATION AND BACKFILL

- A. Excavation and backfill shall be done in accordance with the Specifications.

3.03 CAST-IN-PLACE BASES

- A. Manhole bases shall be constructed of Class A concrete to the form and dimension shown on the detailed Plans. Said concrete bases shall be formed and poured on undisturbed soil and/or on pipe bedding material. That portion of the base above the invert elevation of the sewer pipe shall be formed to provide a smooth channel section as shown on the Plans. The forms shall be checked and approved by the Engineer for accuracy of dimensions and relative smoothness prior to pouring the base. Channels shall vary uniformly in size and shape from inlet to outlet if required. The manhole base shall be poured as one monolithic pour.
- B. Joint Sealing Compound
 1. The sealing compound shall be applied as follows:
 2. The joint shall be cleaned with a brush.
 3. The silicon treated protective paper shall be removed from one side of the preformed rope and reformed rope shall be laid paper side up on the cleaned joint surface. The surface shall be pressed firmly end-to-end around the entire joint making 1-inch laps where necessary.
 4. The protective paper shall be removed from the preformed rope and the next section shall be lowered into place.
 5. Sufficient preformed joint sealing compound shall be installed so as to completely fill the joint and show a squeeze-out on the inside and outside of the joint.
- C. Pipe and Fittings

1. All sewer pipe and fittings, including installation at manholes shall conform to the provisions of the specifications of the designated pipe and fittings.

D. Elevation and Installations

1. Each manhole section shall be set perfectly plumb. Section of various heights shall be used in order to bring the top of the manhole ring and cover to the required elevation.
2. The elevations at which manhole frames and covers are to be set shall conform to the requirements set forth on the Plans, but in all cases shall be governed by the Engineer in the field. Manhole frames shall be set at the required grade and shall be securely attached to the top precast manhole shaft unit.

E. Cleaning

1. All manholes shall be thoroughly cleaned of any accumulation of silt, debris, or foreign matter of any kind, and shall be clear of such accumulations at the time of final acceptance.
2. Frames and covers shall be cleaned of foreign matter to ensure a satisfactory fit and appearance prior to final acceptance.

F. Testing

1. It is the intent of the Plans and Specifications that manholes and appurtenances be as watertight and free from infiltration as possible. The adequacy of manholes and appurtenances as to watertightness shall be determined by plugging the sewer pipes and filling the manhole with water. Any evidence of leakage as a result of testing shall be repaired to the satisfaction of the Engineer at the sole expense of the Contractor. When manhole hydrostatic testing is ordered by the Engineer, it shall be at the sole expense of the Contractor.

END OF SECTION

SECTION 02621

GENERAL PIPING SYSTEM AND APPURTENANCES

PART 1 GENERAL

1.01 DESCRIPTION

- A. This section describes the requirements and procedures for piping systems (pressure pipe and gravity pipe) and appurtenances that apply to a number of other complimentary Specification Sections. The items are listed in this section to avoid repetition in sections elsewhere. This section includes, but is not limited to, temporary pipelines, wet taps, flexible pipe couplings, grooved and shouldered end couplings, joint restraint system, field touch up, bolts, nuts, polyethylene wrap, warning/identification tape, tracer wire, gate well and extension stems, meter boxes, abandonment and removal of existing facilities, salvage, and disposal.

1.02 REFERENCE STANDARDS

The publications listed below form part of this specification to the extent referenced and are referred to in the text by the basic designation only. Reference shall be made to the latest edition of said standards unless otherwise called for.

1. AWWA C105 - Polyethylene Encasement for Ductile-Iron Pipe Systems
2. AWWA C111 - Rubber Gasket Joints for Ductile-Iron Pressure Pipe and Fittings
3. AWWA C200 - Steel Water Pipe - 150 mm (6") and Larger
4. AWWA C203 - Coal-Tar Protective Coatings and Linings for Steel Water Pipelines - Enamel and Tape - Hot Applied
5. AWWA C213 - Fusion-Bonded Epoxy Coating for Interior and Exterior of Steel Water Pipelines
6. AWWA C606 - Grooved and Shouldered Joints
7. AWWA C900 - PVC Pressure Pipe, 100 mm (4") Through 300 mm (12") for Water Distribution
8. AWWA C901 - Polyethylene (PE) Pressure Pipe and Tubing 1/2" (13 mm) Through 3" (76 mm)
9. AWWA C906 - Polyethylene (PE) Pressure Pipe and Tubing 4" (100 mm) Through 65" (1,650 mm)
10. AWWA M11 - Steel Pipe - A Guide for Design and Installation
11. AWWA - Guidelines for Distribution of Non-potable Water

12. ASTM A 36/A 36M -Standard Specification for Carbon Structural Steel
13. ASTM A 47/A 47M - Standard Specification for Ferritic Malleable Iron Castings
14. ASTM A 53 - Standard Specification for Pipe, Steel, Black and Hot-Dipped, Zinc-Coated Welded and Seamless
15. ASTM A 108 - Standard Specification for Steel Bars, Carbon, Cold Finished, Standard Quality
16. ASTM A 183 - Standard Specification for Carbon Steel Track Bolts and Nuts
17. ASTM A 283/A 283M - Standard Specification for Low and Intermediate Tensile Strength Carbon Steel Plates, Shapes and Bars
18. ASTM A 307 - Standard Specification for Carbon Steel Bolts and Studs
19. ASTM A 325/A 325M - Standard Specification for High-Strength Bolts for Structural Steel Joints
20. ASTM A 510/A 510M - Standard Specification for General Requirements for Wire Rods and Course Round Wire, Carbon Steel
21. ASTM A 512 - Standard Specification for Cold-Drawn Buttweld Carbon Steel Mechanical Tubing
22. ASTM A 536 - Standard Specification for Ductile Iron Castings
23. ASTM A 568/A 568M - Standard Specification for Steel, Sheet and Strip, Carbon, Hot-Rolled, Structural Quality and Cold Rolled
24. ASTM D 2000 - Standard Classification System for Rubber Products in Automotive Applications
25. ASTM F 593 - Specifications for Stainless Steel Bolts, Hex Cap Screws, and Studs
26. ASTM F 594 - Specification for Stainless Steel Nuts
27. ANSI B1.1 - Unified Inch Screw Threads
28. ANSI B1.2 - Gages and Gauging for Unified Inch Screw Threads
29. NSF - National Sanitation Foundation
30. SSPWC - Standard Specifications for Public Works Construction ("Orangebook")

1.03 RELATED WORK SPECIFIED ELSEWHERE

- A. Specifications 02225, 02401, and 11311.

1.04 LINING CONTAMINATION PREVENTION

- A. Volatile organic compounds present in the linings of items in contact with potable water or recycled water shall not exceed concentrations allowed by the latest requirements of the State Office of Drinking Water and Department of Health Services. Some products and materials may also require proof of NSF certification on the lining materials to be used.

1.05 TEMPORARY PIPELINES

- A. Temporary pipelines, where shown on the Approved Plans or required by the Engineer, shall be furnished, installed, disinfected, connected, maintained, and removed by the Contractor. The Contractor shall perform bacteriological sampling and testing. The contractor shall provide a submittal to the Owner showing pipe layout, materials, sizing, flow calculations, schedule and duration of use, and disinfection for all temporary piping. The submittal shall be reviewed and approved by the Engineer prior to ordering or delivery of any materials.

1.06 PIPE TAPPING (WET TAP)

- A. All pipe tap (wet tap) connections to existing pipelines, whether for mainline extensions or service laterals, shall be performed by the Contractor. The Contractor shall provide materials and labor to excavate, pour thrust block, backfill, compact, and repair pavement as indicated in this Section.

1.07 JOINT RESTRAINT SYSTEM

- A. Joint Restraint Systems may be used for PVC or ductile-iron pipe only with prior approval of the Engineer. Joint restraint systems shall be used in the place of, or in conjunction with, concrete thrust blocks as directed. Contractor shall submit shop drawings, calculations, and catalog data for joint restraint systems.
- B. Splined gaskets, also known as joint restraint gaskets, may be used for PVC or ductile-iron pipe located within casings, or for PVC pipe casings, only with prior approval of the Engineer.

1.08 POLYETHYLENE ENCASEMENT

- A. Polyethylene encasement shall be used for all ferrous metal materials not otherwise protectively coated.
- B. Polyethylene wrap shall be used for the protection of buried ductile-iron fittings and valves.
- C. Polyethylene sleeves shall be used for the protection of buried ductile iron pipe.
- D. Polyethylene wrap or sleeves may also be installed around buried PVC pipe for recycled water identification.

1.09 WARNING/IDENTIFICATION TAPE

- A. Warning/identification tape shall be installed to identify location of underground utilities and to act as a warning against accidental dig-ins of buried utilities. Warning/identification tape shall be used on all underground water and recycled water mains, potable and recycled water

irrigation systems, sewer mains, and all related appurtenances. Warning/identification tape shall also be used on cathodic protection wiring systems and tracer wire brought into and out of access ports.

1.10 TRACER WIRE

- A. Tracer wire shall be installed on all buried water and recycled water mains for the purpose of providing a continuous signal path used to determine pipe alignment after installation. Tracer wire is not required in installation of sewer mains.

1.12 VALVE STEM EXTENSION

- A. Valve Stem Extensions shall be installed when the valve-operating nut is more than 1.5m (5') below grade. Stem extensions shall be of sufficient length to bring the operating nut to a point between 300mm (12") and 450mm (18") below the gate well lid.

1.14 RECYCLED WATER IDENTIFICATION

- A. Facilities installed for the use of recycled water shall be identified with purple color coating, identification labels, or signs.

1.15 CURB IDENTIFICATION MARK FOR SERVICES

- A. The Contractor shall mark the location of all potable water, recycled water and sewer laterals at the curb crossing by stamping the face of the curb in 50mm (2") high letters as described below:
 - B. Potable water laterals shall be stamped with a letter "W".
 - C. Recycled water laterals shall be stamped with a letter "RW".
 - D. Sewer laterals be stamped with a letter "S".

PART 2 MATERIALS

2.01 TEMPORARY PIPELINES

- A. Temporary piping layout, materials and appurtenances shall be as indicated on the approved submittal.

2.02 FLEXIBLE MECHANICAL PIPE COUPLINGS

- A. Flexible mechanical pipe couplings shall be in accordance with the Approved Materials List and as described below:
 - B. Steel Couplings shall have middle rings made of steel conforming to ASTM A 36/A 36M, A 53 (Type E or S), or A 512 having a minimum yield strength of 207 MPa (30,000 psi). Follower rings shall be ductile-iron per ASTM A 536, or steel per ASTM A 108, Grade 1018 or ASTM A 510, Grade 1018. Minimum middle ring length shall be 175 mm (7") for pipe sized 150 mm (6") through 600 mm (24").

- C. Sleeve bolts shall be made of stainless steel per ASTM A193 and shall have a minimum yield strength of 276 MPa (40,000 psi), an ultimate yield strength of 414 MPa (60,000 psi), and shall conform to AWWA C111.

2.03 GROOVED END OR SHOULDERED COUPLINGS FOR DUCTILE IRON OR STEEL PIPE

- A. Grooved end or shouldered couplings shall be in accordance with the Approved Materials List and as described below:
- B. Use square-cut shouldered or grooved ends per AWWA C606. Grooved-end couplings shall be malleable iron per ASTM A 47, or ductile iron per ASTM A 536. Gaskets shall be per ASTM D 2000.
- C. Bolts in exposed service shall conform to ASTM A 183, 69 MPa (10,000 psi) tensile strength.

2.04 JOINT RESTRAINT SYSTEM

- A. Joint Restraint Systems shall be ductile-iron and shall consist of a split-ring restraint with machined (not cast) serrations - on the inside diameter, a back-up ring, and connecting bolts, and shall be selected from the Approved Materials List. Splined gaskets, also known as joint restraint gaskets, shall be a rubber-ring type with stainless steel locking segments vulcanized into the gasket.

2.05 FIELD TOUCH-UP APPLICATIONS

- A. All surfaces of metallic appurtenances in contact with potable water and not protected from corrosion by another system shall be shop-coated by the manufacturer. Appurtenances with damaged coatings shall be repaired or replaced as directed by the Engineer. Touch-up of damaged surfaces, when allowed by the Engineer, shall be performed in accordance with the manufacturer's recommendations.

2.06 BOLTS AND NUTS

- A. Bolts and nuts shall be as indicated below and shall be selected from the Approved Materials List.
- B. Cadmium-plated, zinc-plated or fluoropolymer coated bolts and nuts shall be used for the installation of pipelines up to 500mm (20") diameter and shall be carbon steel conforming to ASTM A307, Grade A, unless otherwise indicated on the approved drawings. Bolts shall be standard ANSI B1.1, Class A coarse threads. Nuts shall be standard ANSI B1.1, Class 2H coarse threads.
- C. Stainless steel bolts and nuts shall be used for the installation of pipelines 600mm (24") diameter and larger and for submerged flanges. Bolts and nuts shall be Type 316 stainless steel conforming to ASTM A193, Grade B8M for bolts, and Grade 8M for nuts. All bolt heads and nuts shall be hexagonal, except where special shapes are required. Bolts shall be of such length that not less than 6.4mm (¼") or more than 12.7mm (½") shall project past the nut in tightened position.

2.07 FLANGE GASKET

- A. Flange gaskets shall be full-face, 1/8 inch thick, cloth-inserted rubber sheet or Engineer's approved equal.

2.08 POLYETHYLENE ENCASEMENT

- A. Polyethylene encasement shall be as indicated below and shall be selected from the Approved Materials List. Polyethylene materials shall be kept out of direct sunlight exposure.
- B. Polyethylene sleeves shall be a minimum 0.305mm (0.012" or 12 mil) thick polyethylene plastic in accordance with AWWA C105.
- C. Polyethylene wrap shall be a minimum 0.203mm (0.008" or 8 mil) thick polyethylene plastic in accordance with AWWA C105.
- D. Polyethylene wrap and sleeves shall be clear for use with potable water and purple for use with recycled water.
- E. Polyethylene or vinyl adhesive tape a minimum of 50mm (2") wide or plastic tie straps shall be used to secure polyethylene encasement.

2.09 WARNING/IDENTIFICATION TAPE

- A. Warning/identification tape shall be as indicated below and in accordance with the Approved Materials List.
- B. Tape shall be an inert plastic film (non-metallic) formulated for prolonged underground use that will not degrade when exposed to alkalies, acids and other destructive substances commonly found in soil.
- C. Tape shall be puncture-resistant and shall have an elongation of two times its original length before parting.
- D. Tape shall be colored to identify the type of utility intended for identification. Printed message and tape color shall be as follows:

<u>Printed Message</u>	<u>Tape Color</u>
Caution: Waterline Buried Below	Blue
Caution: Recycled Waterline Buried Below	Purple
Caution: Sewerline Buried Below	Green
Caution: Cathodic Protection Cable Buried Below	Red
Caution: Electric Line Buried Below	Red

Ink used to print messages shall be permanently fixed to tape and shall be black in color with message printed continuously throughout.

- E. Tape shall be a minimum of 0.102mm (0.004" or 4mil) thick x 150mm (6") wide with a printed message on one side. Tape used with the installation of onsite potable and recycled water irrigation systems shall be a minimum of 100mm (4") wide.

2.010 TRACER WIRE

- A. Tracer wire shall be as indicated below and shall be selected from the Approved Materials List.
- B. Tracer wire shall be #14 AWG solid copper UF type wire with cross-linked polyethylene insulation. The insulation shall be white or yellow in color.
- C. Wire splices (at pipe tees, crosses and laterals) shall be accomplished using a direct bury silicone-filled capsule tube with standard wire nut or silicone-filled wire nut connectors of the appropriate size selected from the Approved Materials List.

2.011 VALVE STEM EXTENSIONS

- A. Stem extensions shall be complete with operating nut, location ring, and lower socket to fit valve-operating nuts. The configuration of the extension stem socket shall match that of the valve it operates.
- B. Stem extensions shall be square fiberglass tubing glued together to make a continuous one-piece unit used to a maximum length of 2.4m (8').
- C. Steel stem extensions shall be used where the maximum length of the extension exceeds 2.4m (8') or at the request of the Engineer. Steel stem extensions may be round or square hot-dipped galvanized steel tubing of solid design (no pinned couplings permitted) with guides.

2.012 RECYCLED WATER IDENTIFICATION

- A. Materials used to identify pipe and appurtenances used for recycled water and not manufactured in purple color.

PART 3 EXECUTION

3.01 TEMPORARY PIPELINES

- A. All temporary piping, fittings, and service connections shall be furnished, installed, and maintained by the Contractor, and the Contractor shall make connections to a water source designated by the Engineer.
- B. All pipe, valves, fittings, hose and connections furnished by the Contractor shall be of good quality, clean, and suitable for conveying potable water in the opinion of the Engineer.
- C. The temporary pipe shall be installed in such a manner that it will not present a hazard to traffic and will not interfere with access to homes and driveways along its route.
- D. Valves shall be installed at 60m (200') intervals or as directed by the Engineer. The use of pressure reducing valves (PRV) may be required as directed by the Engineer.
- E. The Contractor shall be responsible for disinfecting all pipe, connections, flushing, and assisting Utilities Inc. in taking water samples for bacteriological testing in accordance with Section 15041.

- F. Following disinfection and acceptance of the temporary pipe as a potable water system, the Contractor shall maintain continuous service through the temporary piping to all consumers normally served both directly and indirectly by the pipeline.
- G. Upon completion of the work, the Contractor shall remove the temporary piping and appurtenances.
- H. If progress in making repairs to the temporary pipeline is inadequate, the Engineer may order necessary corrective measures. Corrective measures may consist of directing Utilities Inc. personnel or another contractor to complete the work. All costs for corrective measures shall be borne by the Contractor.

3.02 FLEXIBLE MECHANICAL PIPE COUPLINGS

- A. Flexible mechanical-type couplings shall conform to ANSI/AWWA C606, "Standard for Grooved and Shouldered Type Joints."
- B. Flexible mechanical-type couplings of nominal size less than 12 inches shall be used with cut-grooved standard IPS pipe and shall be Romac Macro HP two-bolt Extended Range Couplers, Sigma C153 MJxMJ Couplers, or Engineer's approved equal.
- C. Bolts, nuts and washers for couplings to be buried shall be cadmium plated, high-strength, low-alloy steel meeting the composition requirements of AWWA C111, stainless steel 304 or 316. All other installations shall have bolts and nuts meeting the requirements of AWWA C111. Type II Service Class 1, zinc-plated bolts, nuts and washers are also acceptable.

3.03 GROOVED-END OR SHOULDERED COUPLINGS FOR DUCTILE-IRON OR STEEL PIPE

- A. Grooved-end or shouldered couplings shall be installed in accordance with the manufacturer's recommendations and as described below:
- B. Grooved-end or shouldered joint couplings shall be installed per AWWA C606 and the manufacturer's recommendations.
- C. Clean loose scale, rust, oil, grease, and dirt from the pipe or fitting groove and touch-up the epoxy coating as necessary, allowing time for curing before installing the coupling.
- D. Clean the gasket before installation. Apply a lubricant selected from the Approved Materials List to the gasket exterior including lips, pipe ends, and housing interiors.
- E. Fasten the coupling alternately and evenly until the coupling halves are seated. Follow the manufacturer's recommendations for bolt torque using a properly calibrated torque wrench.

3.04 JOINT RESTRAINT SYSTEM

- A. Joint Restraint Systems shall be installed in accordance with the manufacturers recommendations and as described below:

- B. Length of pipe to be restrained on each side of bends, tees, reducers and other fittings shall be determined by the Private Engineer or manufacturer of the restraint device.
- C. Split ring restraint shall be installed on the spigot end of pipe, connected to a back-up ring which seats behind the bell of the adjoining pipe or fitting.
- D. Restraint devices can be installed prior to lowering pipe into the trench.
- E. Splined gaskets, also known as joint restraint gaskets, shall be installed in accordance with the manufacturer's recommendations.

3.05 BOLTS AND NUTS

- A. All bolts and nuts shall be new and unused.
- B. Bolts and nuts shall be cleaned, if needed, by wire brushing and shall be lubricated prior to assembly.
- C. Tighten nuts uniformly and progressively.
- D. Buried bolts and nuts shall receive a heavy coat of protective grease coating selected from the Approved Materials List prior to being wrapped with polyethylene.
- E. All stainless steel bolts shall be coated with an anti-seize compound selected from the Approved Materials List.
- F. Bolts and nuts shall not be reused once tightened. Used bolts and nuts shall be discarded and removed from the job.

3.06 POLYETHYLENE ENCASEMENT

- A. Polyethylene encasement shall completely encase and cover all metal surfaces.

Pipe: All ductile-iron pipe shall be encased with polyethylene sleeves in accordance with Method A described in AWWA C105, or with polyethylene wrap in accordance with Method C described in AWWA C105.

Fittings: Fittings such as tees, bends and reducers shall be encased with polyethylene wrap in accordance with AWWA C105.

Valves: Valves shall have only the stem and operating nut exposed and the wrap shall be attached so that valve operation will not disturb the wrapping or break the seal.

- B. Polyethylene sleeves shall be secured with polyethylene or vinyl adhesive tape or plastic tie straps at the ends and quarter points along the sleeve in a manner that will hold the sleeve securely in place during backfill. Polyethylene wrap shall be secured with polyethylene or vinyl adhesive tape in a manner that will hold the wrap securely in place during backfill.

3.07 WARNING/IDENTIFICATION TAPE

- A. Warning/Identification Tape shall be installed as described below in accordance with the Drawings.
- B. Tape shall be placed at the top of the pipe zone 300mm (12") above and centered over the utility intended for identification. Tape used with onsite potable and recycled water irrigation systems shall be installed at 150mm (6") above the pipe.
- C. Tape shall be installed with the printed side up and run continuously along the entire length of the utility intended for identification. Tape shall be installed on the main piping and all appurtenant laterals, including blowoffs, air valve assemblies, fire hydrants, and services. Tape splices shall overlap a minimum of 600mm (24") for continuous coverage.
- D. Tape shall be installed prior to placement of the Trench Zone Backfill.

3.08 TRACER WIRE

- A. Tracer wire shall be installed as described below in accordance with the Drawings.
- B. Tracer wire shall be installed with all water and recycled water mains.
- C. Wire shall be placed on the top centerline of the pipeline and shall run continuously along the entire length of pipe prior to placement of trench backfill. Wire shall be mechanically and electrically continuous throughout the pipeline, including within pipe casings.
- D. Tracer wire shall be secured to the pipe at 1.8m (6') intervals with plastic adhesive tape, duct tape or plastic tie straps. The wire may alternately be secured to the pipe by looping the tracer wire around itself such that tracer wire remains continuous atop the pipe during backfill operations.
- E. Tracer wire access ports shall be installed in accordance with the Drawings within the concrete splash pad of all fire hydrants installed as a part of the work. Tracer may terminate within meter boxes, blow off boxes, CP test boxes or air valve enclosures only as directed by the Engineer at intervals of not more than 305m (1,000'). Locations of all tracer wire access ports installed shall be noted on the as-built drawings.
- F. Wire shall extend into the access port and terminate with a coiled 600mm (24") length of wire. All tracer wire not located atop pipe shall be installed within a conduit at a minimum depth of 600mm (24") in accordance with the Drawings.
- G. Splices shall be installed only when necessary and shall be made using a wire connector selected from the Approved Materials List.
- H. The Contractor shall test tracer wire for electrical continuity in the presence of the Engineer prior to the installation of any paving over atop pipelines or appurtenances. Testing shall be accomplished using a Progressive Electronics 77M tone generator, or similar device, and a testing telephone handset.

3.09 VALVE STEM EXTENSIONS

- A. Valve Stem Extensions shall be installed when the valve-operating nut is more than 1.5m (5') below grade. Stem extensions shall be of sufficient length to bring the operating nut to a point

between 300mm (12") and 450mm (18") below the gate well lid. Valve stem extensions shall be installed in accordance with the Drawings.

3.010 INSTALLATION OF TEMPORARY END CAPS TO MAINTAIN SERVICE

- A. Before excavating for new mains that are to replace existing pipes or services, it may be necessary to install temporary end caps on existing pipes that are later to be abandoned or connected to in order to maintain service to customers or fire protection during construction. When indicated on the Approved Plans or when directed by the Engineer, Contractor shall install such temporary end caps as indicated below and in accordance with the Drawings.
- B. For existing water mains 350mm (14") or less in diameter, the existing pipe shall be cut cleanly and fitted with a rubber-gasketed ductile-iron solid end cap specifically designed for the size and type of pipe being temporarily capped. The end cap shall be adequately braced with a concrete thrust block poured against undisturbed material or as otherwise required to insure that no movement or leakage occurs.
- C. End caps shall be fitted with 50mm (2") tapped outlets if indicated on the Approved Drawings or if directed by the Engineer to provide a temporary 50mm (2") blowoff or a connection to a temporary water source.
- D. Existing pipes 400mm (16") or larger shall not be fitted with temporary end caps.
- E. Contractor shall maintain the temporary cap throughout the duration of the work and shall remove and dispose of all temporary materials used when the final connection has been made or when the temporary end cap is no longer required. Contractor shall install concrete plugs as described elsewhere within this section if the pipeline on which the end cap was installed is to be permanently abandoned.

3.011 PERMANENT ABANDONMENT OR REMOVAL FROM SERVICE OR EXISTING FACILITIES

- A. Permanent abandonment or removal from service of existing mains, appurtenances or water services shown on the Approved Plans or as called for by the Engineer shall be as indicated below and in accordance with the Drawings. All materials removed during construction operations shall be salvaged or disposed of in accordance with this Section. Permanent abandonment or removal from service of existing mains, appurtenances or water services shown on the Approved Plans shall be considered to include the complete removal of fittings such as tees, wyes, or tapping saddles that connect the pipeline(s) to be abandoned to source pipelines unless specifically shown otherwise on the Approved Plans. Segments of source pipelines so removed shall be replaced with straight pipe and appropriate couplings selected from the Approved Materials List or as directed by the Engineer.
- B. Abandonment in place:
 - 1. Existing pipe 100mm (4") and smaller shall have a short sections of pipe removed and pipe ends encased in concrete at intervals of 60m (200').
 - 2. Existing pipe 150mm (6") through 350mm (14") shall be cut and plugged with concrete or shall be pressure-grouted at intervals of 60m (200').

3. When existing pipe 350mm (14") or less is cut and plugged, or when a section is removed and the pipe ends are encased in concrete, a single excavation shall be performed to plug all exposed ends created by cutting the pipeline. The act of excavating and plugging all exposed ends is considered as a single "cut-and-plug."
4. Existing pipe 400mm (16") and larger shall be entirely filled by pressure-grouting or by blown sand.
5. Ends of all pipe segments to be abandoned shall be filled with concrete in accordance with the Drawings.
6. All valves shall be turned to the closed position.
7. Gate wells shall be cut 600mm (24") below grade and filled with concrete or removed and replaced with compacted backfill.
8. Water service corporation stops shall be closed. Meter boxes and curb stops shall be removed.
9. Water services to be abandoned that are connected to pipelines that will remain in service shall be abandoned in-place in accordance with the Drawings.
10. Sewer laterals shall be cut and plugged with concrete at the main as directed by the Engineer for the specific circumstance and material type identified.
11. Sewer manholes shall have the cover and frame, concrete ring, grade rings and cone section removed. Inlet and outlet piping shall be plugged with concrete, manhole void shall be filled with sand, and a 300mm (12") thick, reinforced concrete slab shall be poured over the top of remaining manhole. The Contractor shall backfill hole to ground surface with compacted select fill.

C. Removal by excavation:

1. Existing pipe and appurtenances shall be removed from the ground as indicated on the Approved Plans or as directed by the Engineer. All materials removed during construction operations shall be salvaged or disposed of in accordance with this Section.
2. Contractor shall provide measures that allow for the removal of existing sewer mains and appurtenances with no leakage of raw sewage. Transportation of sewer mains and appurtenances removed from service shall be in waterproof trucks to prevent raw sewage from leaking on public streets.
3. Removal of asbestos-cement pipe (ACP) and sewer mains and appurtenances shall be in accordance with all applicable State and Federal requirements.
4. Backfill, compaction, and surface repair of all excavations for removal of pipe and appurtenances shall be made in accordance with the Approved Plans, Section 02225 of the Standard Specifications, and the Drawings.

3.012 SALVAGE

- A. When the Contractor is required to remove existing pipe and appurtenances, or portions thereof, from the ground, such materials may, at the discretion of the Engineer, be considered salvage. All materials identified as salvage are considered property of Utilities Inc.
- B. The Contractor shall remove and temporarily stockpile all materials identified as salvage in a safe location that will not disrupt traffic or shall deliver salvage to the Utilities Inc.'s Field Operations Yard as directed by the Engineer.
- C. The Contractor shall legally dispose of all other materials in an appropriate manner. Disposal is the responsibility of the Contractor. Obtain concurrence from the agency having disposal jurisdiction with respect to disposal sites and transportation methods.

3.013 RECONNECTIONS

- A. The Contractor may encounter unused service laterals or appurtenant piping connected to an existing pipeline being replaced. Laterals and appurtenances piping that will not be connected to the new pipeline shall be abandoned as described above.
- B. Existing service laterals or appurtenances shall be connected to new pipelines as shown on the Approved Plans or as directed by the Engineer in accordance with the Drawings.

3.014 DISPOSAL

- F. All materials removed during construction operations and not identified by the Engineer, as salvage shall be legally disposed of in accordance with all applicable Local, State, and Federal requirements.
- B. Disposal of Asbestos-Cement Pipe requires special handling and attention, including but not limited to, encapsulation within airtight packaging, submittal of certification letters and/or waste profile statements, and the use of a NV-OSHA registered asbestos abatement contractor to transport and dispose of such wastes. Utilities Inc. shall be provided with copies of all applicable documentation regarding the transportation and disposal of Asbestos-Cement pipe. Contractor shall comply with all applicable regulations and all requirements of the disposal site. Contractor is responsible for all costs associated with disposal of materials, specifically including any materials that may contain asbestos.

END OF SECTION

SECTION 02625

PRESSURE PIPE, VALVES, AND FITTINGS

PART 1 GENERAL

1.01 SUMMARY

- A. Furnish all materials, equipment and services required for a complete installation of ductile iron pipe as specified and shown

1.02 REFERENCES

- A. ANSI/AWWA C151/A21.51 - Ductile-Iron Pipe, Centrifugally Cast in Metal Molds or Sand-Lined Molds for Water and Other Liquids.
- B. ANSI/AWWA C104/A21.4- Cement-Mortar Lining for Ductile-Iron Pipe and Fittings for Water.
- C. ANSI/AWWA C111/A21.11- Cement-Mortar Lining for Ductile-Iron and Gray-Iron Pressure Pipe and Fittings.
- D. ANSI/AWWA C115/A21.15 - Flanged Ductile-Iron and Gray-Iron Pipe with Threaded Flanges.
- E. ANSI/AWWA C110/A21.10- Ductile-Iron and Gray-Iron Fittings, 3 inch through 46 inch, for Water and Other Liquids.
- F. ANSI/AWWA C153/A21.53 - Ductile-Iron Compact Fittings, 3 inch through 12 inch, for Water and Other Liquids.
- G. ANSI/AWWA C600 - Installation of Ductile-Iron Water Mains and Their Appurtenances.
- H. AWWA C901 – Polyethylene (PE) Pressure Pipe and Tubing 1/2” (13 mm) Through 3” (76 mm)
- I. AWWA C906 – Polyethylene (PE) Pressure Pipe and Tubing 4” (100 mm) Through 65” (1,650 mm)
- J. ANSI/AWWA C111/A21.11 - Mechanical Joint Retainer Glands
- K. ANSI/AWWA C151/A21.57 - Mechanical Joint Pipe Centrifugally cast in metal molds.

1.03 RELATED WORK SPECIFIED ELSEWHERE

- A. SECTION 02675 PRESSURE AND LEAKAGE TESTING
- B. SECTION 02225 TRENCH EXCAVATION AND BACKFILL
- C. SECTION 02621 GENERAL PIPING SYSTEM AND APPURTENANCES

1.04 SUBMITTALS

- A. Shop Drawings: Submit Shop Drawings in accordance with the requirements in Section 01300.
- B. Submit hydrostatic test reports.

1.05 QUALITY ASSURANCE

- A. Certifications: Furnish certified affidavit of compliance for all pipe and other products or materials furnished under this Section.

PART 2 PRODUCTS

2.01 MATERIALS

- A. All materials shall be new and of current manufacture, and in accordance to the standards specified herein.

2.02 POLYVINYL CHLORIDE (PVC) WATER PIPE

- A. Water pipe shall AWWA C900, Class 150 PVC, for pipe 12 inch and under and AWWA C905 Class 150 PVC for pipe greater than 12 inches, unless other pressure class is indicated on the drawings.
- B. PVC pipe and fittings shall be manufactured from Type 1, Grade 1 “normal Impact PVC, Maximum Chemical Resistance Grade” as specified in ASTM D1784. Pipe dimensions shall be as specified in ASTM D1785. Fitting dimensions shall be as specified in ASTM D2466 and D2467.
- C. PVC JOINTS
 1. Joints for PVC pipe shall be the push-on type and the joints and gasket materials shall meet the requirements of AWWA C900.
 2. Where fittings are required, use ductile iron push-on or mechanical joint fittings. Restrained type fittings for PVC shall be ductile iron MJ with a split ring restraining clamp or special PVC restrained fittings or locking bell joints.

Acceptable restrained joint fittings are manufactured by EBAA Iron, Uni-Flange, and Smith-Blair, Inc.

2.03 HIGH DENSITY POLYETHYLENE PIPE

- A. High Density Polyethylene (HDPE) pipe shall conform to ASTM D 3350 designation PE-4710. The pipe shall have a minimum pressure rating of 100 pounds per square inch.
- B. The diameter and standard dimension ratio (DR) for the piping shall be as shown on the Drawings.

- C. The pipe shall be homogeneous throughout and free of visible cracks, holes, foreign inclusions or other injurious defects. It shall be uniform in color, opacity, density, and other physical properties.
- D. HDPE pipe shall have an ASTM D-3350 material Cell Classification of no less than 335434C.
- E. All pipe shall comply with ASTM F714.
- F. The polyethylene compound shall contain a minimum of 2 percent carbon black to withstand outdoor exposure without loss of properties. The polyethylene compound shall have a minimum resistance of 5,000 hours when tested for environmental stress crack in accordance with requirements of ASTM 1693.
- G. Pipes and fittings shall be homogenous throughout and free of visible cracks, holes (other than intentional manufactured perforations), foreign inclusions, or other deleterious effects, and shall be uniform in color, density, melt index, and other physical properties.
- H. Fittings at the ends of pipes shall consist of polyethylene unless indicated otherwise on the Drawings. Fittings supplied by manufacturers other than the supplier of the pipe shall not be permitted without the approval of the Engineer. HDPE fittings shall be in accordance with ASTM D3261.
- I. The pipe shall be marked at five foot intervals with a coded number which identifies the manufacturer, SDR size, PPI rating, manufacturing standard reference and production code from which data and place of manufacturer can be determined.
- J. When HDPE pipe is connected to ductile iron pipe, a flange adapter shall be used. A flange-coupling adapter shall be used on the ductile iron pipe. HDPE flange adapters shall be manufactured by the same manufacturer as the pipe using the same resin as the pipe. Each flange adapter shall be furnished with a ductile iron convoluted back-up ring drilled to match the standard ANSI bolt pattern for the nominal diameter of pipe used.
- K. Connection of the pipe and fittings shall be performed by the thermal butt fusion system. HDPE pipe lengths, fittings, and flange adapter connections to be fused shall be of the same type, grade and class of polyethylene compound and supplied by the same raw material supplier.
- L. Pipe and fittings bonded per this specification shall satisfy the requirements of ASME B31.3, latest edition, for pressure piping applications.

2.04 SCREWED STEEL PIPE AND FITTINGS

Steel pipe 2-1/2" and less in diameter shall be standard weight pipe conforming to ASTM A53 and shall be galvanized. Fittings for steel pipe shall be 150 lb. malleable iron conforming to ANSI B16.3 and shall be galvanized. Lines shall be fitted with sufficient unions to facilitate removal of all valves and appurtenances.

2.05 DUCTILE IRON PIPE

- A. Unless otherwise specified or shown on the drawings, ductile iron pipe shall be Class 52 and shall conform to ANSI/AWWA C151/A21.51.
- B. Ductile iron pipe shall be cement mortar lined in accordance with ANSI/AWWA C104/A21.4, except as modified herein.
 - 1. The thickness of the cement mortar lining shall not be less than 1/8 inch for 4 inch through 12 inch diameter pipe; and 3/16 inch for 14 inch through 24 inch diameter pipe.
 - 2. All ductile iron pipe shall be provided with an 8 mil polyethylene or other suitable permeable bulkhead on the ends of the pipe and all special openings.
- C. Ductile iron pipe installed below grade shall employ either mechanical joints or push-on joints conforming to ANSI/AWWA C111/A21.11 unless otherwise specified.
- D. Ductile iron pipe installed above grade shall employ flanged joints conforming to ANSI/AWWA C115/A21.15.
- E. Ductile-iron pipe and appurtenant components and materials shall be selected from the Approved Materials List in accordance with the Drawings.
- F. Ductile iron pipe having push-on, mechanical, or plain end connections shall be furnished within the following classes:

Pipe Diameter	Minimum Pressure Class	Minimum Thickness Class
Under 6-inch	350	52
6 to 16-inch	350	50
20 to 24-inch	300	50
30 to 36-inch	250	50
42 to 60-inch	200	50

- G. Minimum thickness class for pipe having threaded flanges or threaded shoulders shall be Class 53.
- H. Minimum thickness class for pipe having grooved end joints shall be as shown in the following table unless otherwise noted on the approved Drawings:

Pipe and Fitting Size (Diameter, in.)	Wall Thickness per AWWA C606
16 and smaller	Class 53
20	Class 54
24	Class 56

A. GASKETS

1. Mechanical joint rubber gasket configuration and materials shall comply with AWWA C111 and shall be in accordance with the applicable joint type and pressure rating of the piping system.
2. Flange gaskets shall be 3.2mm (1/8") thick acrylic or aramid fibers bound with nitrile for all sizes of pipe. Gaskets shall be full-face type with pre-punched holes.
3. Push-on joint rubber gaskets shall be per AWWA C111.
4. If organic solvents or petroleum products are encountered during the course of the work, alternate gasket materials or joint treatment may be required by the Engineer.

I. FITTINGS

Unless otherwise specified or shown on the Drawings, all fittings to be used with ductile iron pipe shall conform to the quality and wall thickness specified in ANSI/AWWA C110/A21.10 or as specified in AWWA C153/A21.53.

1. All gray-iron and ductile iron fittings shall be lined with cement mortar in accordance with ANSI/AWWA C104/A21.4.
2. All fittings and joint connections shall be thoroughly cleaned and coated or wrapped in accordance with AWWA C105.
3. All ductile iron mechanical joint fittings shall incorporate retainer glands, manufactured to a minimum ductile 60-40-12 grade for joint restraint. Set screws are to be manufactured from AISI 4140 steel case and core hardened un-plated. Set screws are to have knurled and cupped points. Drilling for set screws is to be AT a 10-degree angle. Screws for 3"-12" pipe are to have breakable automatic torque caps.

J. ACCESSORIES

1. Rubber gaskets for the sealing of joints on ductile iron pipe shall conform to ANSI/AWWA C111.A21.11.
2. Cement for mortar lining shall conform to the ANSI/AWWA C104.A21.4 and shall be Type II or Type V. A fly ash or pozzolan shall not be used as a cement replacement.
3. Water for cement mortar shall be potable water, clean and free from organic matter, strong alkalis, vegetable matter and other impurities.

K. SOURCE QUALITY CONTROL

1. Testing: All pipe shall be subject to a hydrostatic pressure test at the manufacturer's plant.
2. Inspection of Materials: All pipe and fittings shall be true, circular, and concentric with the barrel of the pipe cut off on a plane at right angles to the longitudinal axis of the pipe.

3. Interior: All pipe and fittings shall have smooth interiors and shall be free from injurious cracks, checks, blisters, broken extremities, and other imperfections.

2.06 VALVES

A. Gate Valves, 2 inch to 14 inch

1. Provide gate valves equal to Mueller 2360 Series conforming to AWWA C509, minimum 150 psig working pressure (unless indicated otherwise on the plans), resilient seated wedge, non-rising stem, O-ring packing, 2 inch square operator nut for buried service. Left hand opening, counter clockwise.
2. Factory applied minimum 6 mils dry film thickness, epoxy coating on all interior and exterior ferrous surfaces. Epoxy coating per AWWA C550. Valves 2 inch and smaller
3. Ball valve. Threaded bronze body chrome plate brass ball glass filled Teflon seats with standard port. Rated for 150 psi minimum working pressure. Valves mounted in air lines shall be suitable for 225° F.
4. Gate valve. Threaded all bronze, double disk, non-rising stem. Rated for 150 psi minimum working pressure.

B. Butterfly Valves:

1. General: Butterfly valves shall be of the tight closing, rubber seated type and fully comply with the latest revision of AWWA Standard C504, Class as required, and NSF61 where applicable. Valves shall be bubble-tight at rated pressure class in either direction, and shall be satisfactory for applications, involving throttling service and for applications requiring valve actuation after long periods of inactivity. Valve discs shall rotate 90° from the full open position to the tight shut position. Regardless of valve size, angular disposition of disc can be up to 1" off center without leakage.
2. Actuator: Provide hand lever actuator for valves 3 inch to 10 inch and hand wheel operator for valves 12 inch and larger. Provide 2 inch square operator nut and valve box for buried service.
3. Blower Air Discharge: Provide seat and seal materials suitable for a minimum of 225° F for valve application on the blower air discharge.
4. Quality: Provide valves equal to Mueller Lineseal III (Class 150B) butterfly valves.

C. Eccentric Plug Valves:

Provide DeZURIK, or equal, Eccentric Plug Valves conforming to AWWA C517, AWWA C111, ANSI B16.1 and/or ANSI B16.5 as appropriate for Eccentric Plug Valves.

Flanged valves shall conform to the 125 lb standard unless otherwise shown. Valves shall be operated by lever or gear operator unless otherwise shown. Equip valves less than 6 inch with a manual lever actuator. Valves 6 inch and larger shall be equipped with gear operators, lubricated and sealed to prevent entry of dirt and water into the operator. All shaft bearings

shall be furnished with permanently lubricated bearing surfaces. The operator shall clearly indicate valve position. Valves 4 inch and larger shall be epoxy coated in the water passages.

D. Rubber-Flapper Swing Check Valves: A shop drawing submittal is required.

1. Sewage Applications: APCO Series 100R Model 104P3
2. Water Applications: APCO Series 100SR Check Valves
3. Rubber-flapper swing check valves shall have a heavily constructed ductile-iron body and cover. The body shall be long pattern design (not wafer), with integrally cast-on end flanges.
4. Flapper shall be captured between the body and the body cover in a manner to permit the flapper to flex from closed to full open position during flow through the valve. Flapper shall be easily removed without need to remove valve from line. Check valves shall have full pipe size flow area. Seating surface shall be on a 45° angle requiring the flapper to travel only 35° from closed to full open position, for minimum head loss and non-slam closure.
5. The rubber flapper shall be high-strength coated fabric, coated both sides with 70 DURO, which creates an elastic spring effect, molded internally, to assist the flapper to close against a slight head to prevent slamming. When essential to create backflow through the check valve, provide an external backflow device, where specified.

2.07 SERVICE SADDLE CLAMP AND CORPORATION STOPS

- A. Service Saddle Clamp. Service saddle clamp shall be a brass, or epoxy coated steel saddle with stainless steel double strap as manufactured by Ford or an approved equal. Provide CC Type for services of one (1) inch or smaller to provide IPT Type for services larger than one (1) inch. Provide clamp gasket suitable for use with potable water. Provide minimum working pressure of 150 psig.
- B. Corporation Stops. Bronze alloy body with threaded and/or compression type connections suitable for service intended. Provide minimum working pressure of 150 psig.

2.08 VALVE BOX AND RISER

- A. Operating Nut Less than 5 Feet below Surface. Valve boxes shall be two (2) pieces or three (3) piece, depending on the manufacturer's recommendations. Valve boxes shall be the slide-type with a minimum 5-1/4 inch diameter shaft. Valve boxes including upper part, lower part, extensions and lids shall be cast iron. The valve box shall be specifically designed for the type of valve on which it is used. The valve box shall be of proper length for the depth of cover. The word "Water" or "Sewer," as appropriate shall be cast into the top of the lid.
- B. Operating Nut Greater than 5 Feet below Surface. Riser pipe shall be minimum 6 inch diameter PVC or DI pipe, frame and cover per ASTM A48 Class 30 painted or dipped with asphalt paint. Provide extension stem per detail. The word "Water" or "Sewer," as appropriate shall be cast into the top of the lid.

2.09 FLEXIBLE COUPLINGS

- A. Straight type flexible couplings for joining plain end PVC and ductile iron pipe shall be Rockwell No. 431, Dresser Style 153, or equal.
- B. Straight type flexible coupling for joining plain end steel pipe shall be Rockwell No. 411 or Dresser Style 38, or equal.
- C. Transition-type flexible coupling for joining plain end pipe of different outside diameter shall be Rockwell No. 433 or No. 415, or Dresser Style 162, or equal.
- D. Flexible pump connectors. Provide and install rubber expansion joints as shown on the plans. Expansion joints shall be of the arched type. Coupling shall be by means of flanges. Restrain pump discharge connections. Provide Metraflex style 100 single arch, Mercer, American Rubber or an approved equal.

2.010 FLANGED ADAPTERS

The flanged coupling adapters (FCA) shall combine a flexible coupling with a flange to create a compact, flexible fitting to connect plain end pipe to sewage valves using a 150 pound ANSI template.

All steel FCA's shall be coated with a protective coating consisting of fusion bonded epoxy in accordance with AWWA C213, or approved equal. Flanged coupling adapters shall be Rockwell No. 912 or 913, or Dresser Style 127 or 128, or an approved equal.

PART 3 EXECUTION

3.01 BURIED PIPE

Conform to Section 02225 Trench Excavation and Backfill and Section 02621 General Piping system and Appurtenances for all buried pipe.

3.02 HDPE PIPE INSTALLATION

- A. HDPE to HDPE connections shall be made by thermal butt fusion, in accordance with ASTM D2657. Fusion jointing shall utilize a pipe manufacturer approved fusion machine operated by experienced and qualified personnel. The CONTRACTOR shall provide three copies of a "Heat Fusion Qualification Guide," published by the HDPE manufacturer that provides criteria for inspection of thermal fusion joints. The guide shall include criteria for operator training requirements and experience; visual inspection criteria (including photographs) for both intact thermal fusion joints and sample strips cut for thermal fusion joints. The thermal fusion machine operator shall perform a minimum of three test joints in the presence of the ENGINEER. The test joints will be examined from both exterior appearances and from appearance of the joint cross section once the samples have been cut into strips.
- B. Bolted HDPE to HDPE connections shall include a polyethylene flange adapter (stub end) butt fused to the pipe, a backup flange ring, bolts, nuts and a gasket. Flange rings shall be Standard Steel ring Flanges, Class D, in accordance with AWWA C207. High strength bolts, nuts, washers and gaskets shall be in conformance with AWWA C207, Appendix A. Flange

rings, bolts, nuts and washers shall be hot dip galvanized after fabrication per ASTM A153 and A386. Gasket dimensions and bolt lengths shall be per pipe manufacturer's recommendations.

3.03 DUCTILE IRON PIPE INSTALLATION

- A. Install ductile iron pipe in accordance with ANSI/AWWA C600, and the manufacturer's recommendations except as otherwise specified or shown.
- B. All damaged or defective ductile iron pipe and appurtenances shall be rejected and removed from the job site.
- C. Trenches shall be in a reasonably dry condition when the pipe is laid.
 - 1. Employ dewatering methods as required to maintain the trench in a reasonably dry condition.
 - 2. Provide necessary facilities for lowering and properly placing the pipe sections in the trench without damage.
 - 3. The pipe shall be laid carefully to the lines and grades, or to the minimum depths shown, and the sections shall be closely jointed to form a smooth flow line.
- D. The following minimum covers shall be maintained unless otherwise shown:
 - 1. A minimum of 36 inches of cover shall be maintained over pipe 4 inches through 24 inches in diameter where there is not an established street grade.
- E. The maximum allowable joint deflection for push-on type joint and mechanical-joint pipe shall be as follows:

Push-on Type Joint

PIPE SIZE	DEFLECTION ANGLE	MAXIMUM OFFSET (INCHES)		RADIUS OF CURVE (FEET)	
		18FT LENGTH	20FT LENGTH	18FT LENGTH	20FT LENGTH
4" through 12"	2.5	9	10	415	460
14" through 24"	1.5	6	6	690	765

Mechanical-Joint Pipe

PIPE SIZE	DEFLECTION ANGLE	MAXIMUM OFFSET (INCHES)		RADIUS OF CURVE (FEET)	
		18FT LENGTH	20FT LENGTH	18FT LENGTH	20FT LENGTH
4"	4.0	15	17	260	290
6"	3.5	15	15	295	330
8" through 12"	2.5	9	10	415	460
14" through 24"	1.5	6	6	690	765

END OF SECTION

SECTION 02652

PIPE CASING

PART 1 GENERAL

1.01 SUMMARY

- A. The Contractor shall furnish all labor, equipment, and materials required for a complete installation of all pipe casing under the race track as specified and shown on the Plans.

PART 2 PRODUCTS

2.01 STEEL CONDUCTOR PIPE

- A. Unless otherwise shown on the drawings or specified, the casing shall be steel ASTM A 283, Grade C, ASTM A 139 Grade B, or ASTM A 36.
- B. Minimum wall thickness of casing shall be 3/8 inches.

2.02 CASING SPACERS

- A. Casing spacers, shell, and risers shall be manufactured of stainless steel Type 304 with a minimum 14 gauge thickness. The spacer shall be lined with .090 inch thick PVC, the fasteners shall be stainless steel Type 304, and the runners shall be ultra-high molecular weight polymer. Casing spacers shall be Model CCS centered as manufactured by Cascade Waterworks Manufacturing. Company or Engineer approved equal.

2.03 CASING END SEALS

- A. Casing end seals shall be virgin rubber with Type 304 stainless steel bands on each end of the seal. End seals to be installed after water pipe and spacers are in place. End seals shall be Model CCES as manufactured by Cascade Waterworks Manufacturing. Company or Engineer approved equal.

PART 3 EXECUTION

3.01 STEEL PIPE

- A. Pipe casing shall be laid true to line and grade with no bends or changes in grade for the full length of the casing. Variation from line and grade indicated on the drawings shall be limited to 2% lateral alignment and 1% in vertical grade.
- B. If the pipe is to be installed inside the casing, the pipe shall be supported by casing spacer as specified in Section 2.02. The casing spacers shall be located in accordance with the drawings. The annular space between the pipe and the casing shall be backfilled with silica sand. After installation of the pipe, the casing shall be sealed at both ends with casing end seals as specified in Section 2.03.

C. Contractor shall provide dewatering equipment.

3.02 FIELD WELDING OF STEEL PIPE

A. Unless otherwise specified or shown on the drawings, steel pipe casing shall be fabricated with a minimum of 3/8-inch thick steel plates conforming to the requirements of the "Specification for Low and Intermediate Tensile Strength Carbon Steel Plates of Structural Quality," ASTM A 283, Grade C, ASTM A 139 Grade B, or ASTM A 36. All joints shall be welded. Interior joints shall be ground to a smooth finish. Chamfer ends 1/4-inch by 45 degrees on outside edge. All welding shall be performed in accordance with the "Standard for Fabricated Electrically-Welded Steel Water Pipe," AWWA C206. Coatings for steel casing are not required.

END OF SECTION

SECTION 02670

VALVES

PART 1 GENERAL

1.01 SUMMARY

- A. The Contractor shall furnish all valves in accordance with the drawings and specifications. All valves, including component parts thereof, shall equal or exceed the requirements set forth herein, and shall be manufactured by a firm normally engaged in the manufacture of such valves. All valves furnished for the work shall be new and shall be currently under manufacture.

PART 2 PRODUCTS

2.01 MANUFACTURER

- A. All valves shall be manufactured by a manufacturer approved by the Engineer.

2.02 TESTING/STANDARDS

- A. All valves shall be designed for a water working pressure of 150 psi, unless otherwise shown on the drawings or set forth in these specifications.
- B. The Contractor shall install and test all valves furnished in conformance with the drawings and specifications.
- C. The Contractor shall supply to the Engineer records of tests performed on valves or component parts thereof that are required by the AWWA Valve Standard specified in these specifications, if requested by the Engineer any time within a period of one year after the acceptance of the work.
- D. The Contractor shall provide to the Engineer, when requested by the Engineer, an Affidavit of Compliance with the specified AWWA Valve Standard or Section 1.4 of AWWAC550 for each lot or valve size furnished for the work.

2.03 SHOP DRAWINGS

- A. Shop drawings shall be furnished in accordance with Division 01300 of these specifications. Shop drawings shall be submitted with the valve operator in the position and orientation as shown on the drawings.

2.04 FLANGES

- A. Valves shall be furnished with flanged ends, hub ends, "Ring Tite" ends or any combination thereof as required by the drawings or these specifications.

- B. Valve flanges may be raised or plain faced with either a smooth or serrated finish and shall be faced and drilled to ANSI B 16.1, Class 250 cast iron flange dimensions, unless otherwise shown on the drawings or specified in these specifications.
- C. All interior bronze parts of valves, shall conform to the requirements of ASTM B 62, Specification for Composition Bronze or Ounce Metal Castings, unless otherwise required by these specifications or shown on the drawings.

2.05 OPERATOR

- A. All valve operators shall turn clockwise to close.

2.06 SEAT

- A. The Contractor shall lubricate the seat of all rubber-seated valves prior to installation with 111 Silicone Compound as manufactured by Dow Corning, G661 Silicone Compound as manufactured by General Electric, or an Engineer's approved equivalent.

2.07 PLUG VALVE

- A. Plug valves shall be Dezurik type PEC Eccentric Plug Valves with handwheel actuators or an approved equivalent. A submittal will be required.
- B. Valve ends shall be flanged ductile-iron in accordance with Section 02620 unless otherwise called for on the Approved Plans or directed by the District Engineer.

2.08 RUBBER-FLAPPER SWING CHECK VALVE

- A. Swing Check Valves: A shop drawing submittal is required.
 - 1. Sewage Applications: APCO Series 100R Model 104P3
 - 2. Water Applications: APCO Series 100SR Check Valves
- B. Rubber-flapper swing check valves shall have a heavily constructed ductile-iron body and cover. The body shall be long pattern design (not wafer), with integrally cast-on end flanges.
- C. Flapper shall be captured between the body and the body cover in a manner to permit the flapper to flex from closed to full open position during flow through the valve. Flapper shall be easily removed without need to remove valve from line. Check valves shall have full pipe size flow area. Seating surface shall be on a 45° angle requiring the flapper to travel only 35° from closed to full open position, for minimum head loss and non-slam closure.
- D. The rubber flapper shall be high-strength coated fabric, coated both sides with 70 DURO, which creates an elastic spring effect, molded internally, to assist the flapper to close against a slight head to prevent slamming. When essential to create backflow through the check valve, provide an external backflow device, where specified.
- E. Valve ends shall be flanged ductile-iron in accordance with Section 02620 unless otherwise called for on the Approved Plans or directed by the District Engineer.

- F. Check valves shall be tested by the manufacturer and the test results shall be approved by the District Engineer prior to shipment to the project. Check valves must unseat at a head no greater than 600mm (24") water column.

PART 3 EXECUTION

- A. Valves shall be installed at the locations indicated on the plans and per manufacturer's recommendations.

END OF SECTION

SECTION 02675

PRESSURE AND LEAKAGE TESTING

PART 1 GENERAL

1.01 SUMMARY

- A. Furnish all equipment labor and materials required for testing the potable water main pipeline.
 - 1. Water for testing will be provided, in limited quantities, by the OWNER.
 - 2. Testing shall be performed concurrent with installation. Do not install more than 1,000 feet of pipe without being tested, unless approved by the Engineer.

1.02 CONTRACTOR SUBMITTALS

- A. Submit proposed testing schedule for review and approval by the Engineer, at least 3 days prior to testing.
- B. Proposed plans for water conveyance, control and disposal shall also be submitted in writing.

1.03 REFERENCES

- A. AWWA C600, Section 5.2 – Hydrostatic Testing

PART 2 PRODUCTS

2.01 EQUIPMENT

- A. Furnish the pump, pipe connections, and all necessary apparatus for the pressure and leakage tests including gauges and metering devices. Excavate, backfill, and furnish all necessary assistance for conducting the tests.

PART 3 EXECUTION

3.01 GENERAL

- A. Leakage Tests must be in accordance with ASTM C969 and C1244. Leakage test are required for all gravity lines. Perform hydrostatic pressure tests in accordance with AWWA C600, Section 5.2 - Hydrostatic Testing after the pipe or section of pipe has been laid, thrust blocking cured (min. 5 days), and the trench is completely or partially backfilled. Where practical, testing shall be performed fully isolated from the active distribution system.
- B. Valves shall not be operated in either direction at a differential pressure exceeding the rated valve working pressure. A test pressure greater than the rated valve working pressure can result in trapped test pressure between the gates of a double-disc gate valve. For tests exceeding the rated valve working pressure, the test setup should include a provision, independent of the valve, to reduce the line pressure to the rated valve working pressure on

completion of the test. The valve can then be opened enough to equalize the trapped pressure with the line pressure, or the valve can be fully opened if desired.

- C. Water for testing will be furnished in limited quantities by the OWNER; however, the Contractor shall make all necessary provisions for conveying the water from the OWNER designated source to the points of use.

- 1. Testing operations shall be performed in the presence of the Engineer.

3.02 FILLING AND TESTING

- A. The hydrostatic test shall be made by closing valves when available, or by placing temporary bulkheads in the pipe and filling the lines slowly with water.

- 1. Care shall be used to see that all air relief valves are open during filling.
 - 2. After the pipeline, or section thereof, has been completely filled, it shall be allowed to stand under a slight pressure for a sufficient length of time to allow the escape of air from any air pockets, but not less than 24 hours.
 - 3. During this period, bulkheads, valves and connections shall be examined for leaks. If any are found, these shall be stopped or in case of leakage through valves or bulkheads, provision shall be made for measuring such leakage during the test.
 - 4. After the pipe has been filled, a hydrostatic pressure of at least 1.5 times the working pressure at the point of testing shall be applied.
 - 5. Pressure at the lowest point in the pipe shall be 125 percent of the design pressure of the pipeline being tested as shown on the Plans.
 - 6. The test pressure shall not vary by more than ± 5 psi (34.5 kPa) for the duration of the test.
 - 7. The hydrostatic test shall consist of holding the test pressure on each section of the pipelines for a period of at least 2 hours.
 - 8. The water necessary to maintain the pressures shall be measured through a meter or by other means satisfactory to the Engineer.
 - 9. Contractor shall attach a tapping sleeve and valve assembly to the main, and pressure test the assembly prior to making the tap. The required test pressure shall be determined in the same manner as for pipe. The test is acceptable if there is no pressure drop in 15 minutes at test pressure.
 - 10. All exposed pipe, fittings, valves, hydrants, and joints shall be examined carefully during the test. Any damage or defective pipe, fittings, valves, hydrants, or joints that are discovered following the pressure test shall be repaired or replaced with sound material, and the test shall be repeated until satisfactory results are obtained.

11. The leakage shall be considered the amount of water entering the pipe during the test, less the measured leakage through valves and bulkheads.
12. No pipe installation will be accepted if the leakage is greater than that determined by the following equation:

$$L = \frac{SD\sqrt{P}}{133,200}$$

Where:

- L = allowable leakage, in gallons per hour
- S = length of pipe tested, in feet
- D = nominal inner diameter of the pipe, in inches
- P = average test pressure during the leakage test, in pounds per square inch (gauge)

13. Any noticeable leaks shall be stopped and any defective pipe or equipment shall be replaced with new pipe or equipment until the leakage is reduced to permissible limits.
14. Each pipeline valve shall be tested in the closed position with the test pressure maintained on one side and zero pressure on the other side.
 - a. Each valve thus tested shall be drip tight.

B. The hydrostatic test procedure for HDPE Pipe shall consist of two (2) steps: the initial expansion phase and the test period. In order to accommodate the initial expansion of the pipe under test, sufficient make-up water shall be added to the system at hourly intervals for three hours to return to the test pressure. The test period begins after the final addition of make-up water in the expansion phase of the test procedure. The test period is three (3) hours. After this test period, a measured amount of make-up water shall be added to return to test pressure. The amount of make-up water shall not exceed the allowable expansion in U.S. gallons shown in the following table:

THREE HOUR TEST

Nominal Pipe Size (Inches)	Allowance for Expansion (U.S. Gal. Per 100 feet of pipe)
6	0.9
8	1.5
10	2.1
12	3.4
16	5.0
18	6.5

Under no circumstances shall the total test procedure exceed eight hours at 1.5 times the pipe pressure rating. If the test is not completed within eight hours, the test section shall not be re-tested for eight more hours. Repair and re-testing shall continue until a passing test is obtained.

END OF SECTION

SECTION 03150

FORMWORK FOR CAST-IN-PLACE CONCRETE

PART 1 GENERAL

1.01 DESCRIPTION.

- A. Provide formwork for cast-in-place concrete as indicated, specified, and required.
- B. Work Included in This Section. Principal items are:
 - 1. Furnishing, erection, and removal of forms.
 - 2. Shoring and bracing of formwork.
 - 3. Setting of embedded items, and in non-waterbearing locations setting of pipe sleeves for mechanical and electrical work under direction of respective trade requiring holes for passage of pipe or conduit.
- C. Related Work Not Included in This Section.
 - 1. Furnishing embedded items with setting instruction. (Section 03300)
 - 2. Reinforcement. (Section 03200)
 - 3. Concrete mixing, placing and finishing. (Section 03300)
 - 4. Waterstops. (Section 03300)

1.02 QUALITY ASSURANCE.

- A. Three (3) copies of the Contractor's shoring and formwork drawings shall be filed with the Owner for record purposes only and not for review or approval. Forms, shoring and falsework shall be adequate for imposed live and dead loads, including equipment, height of concrete drop, concrete and foundation pressures, stresses, lateral stability, and other safety factors during construction.
- B. Standards and Tolerances. Formwork shall comply with ACI 347R-88, Recommended Practice for Concrete Formwork, except as exceeded by the requirements of regulatory agencies or as otherwise indicated or specified. Except as such other requirements mandate more rigid tolerances, formwork shall be designed and constructed to produce finished concrete conforming to tolerances given in ACI 117-90.

1.03 SUBMITTALS.

- A. Concrete construction joints and expansion joints shall be of the types and locations Indicated. Submit shop drawings showing sequence of forming and concrete placing operations, and location and type of required construction of any proposed expansion joints

not shown on the Drawings. Submit shop drawings at least fifteen (15) working days in advance of form fabrication.

PART 2 PRODUCT

2.01 FORM COATING

- A. Non-grain-raising and non-staining resin or polymer type that will not leave residual matter on surface of concrete or adversely affect bonding to concrete of paint, plaster, mortar, protective coatings, and waterproofing or other applied materials. Coatings containing mineral oils, paraffins, waxes, or other non-drying ingredients are not permitted. For concrete surfaces contacting potable stored water, the coatings and form-release agents shall be completely non-toxic.

2.02 LUMBER.

- A. WWPA No. 1 Structural Light Framing or No. 1 Structural Joists and Planks, or equal. Board forms, if used, shall be No. 2 Common or better, T&G or shiplap, S1S2E or better.

2.03 PLYWOOD.

- A. Plywood shall conform to U.S. Product Standard PS-1 and shall bear APA or DFPA grade mark.
- B. General Use. Exterior type, Grade B-B Plyform, Class I, minimum 5/8" thickness. Mill-oiling is not permitted.
- C. Special Use. Use one or more of the following materials, or equal:
 - 1. HDO coating two sides on Plyform, Class I, Exterior.
 - 2. Exterior Type Grade B-B Plyform, Class I, having 1/8" thick fully adhesive bonded facing on one side of tempered structural hardboard.
 - 3. Birch hardwood plywood, all plies of Arctic white birch, panel faces on both sides phenolic plastic impregnated and faced with phenolic plastic by the hot press process, panel edges factory sealed, bearing manufacturer's logo in lieu of grade mark.

2.04 METAL FORMS.

- A. True to detail, good condition, clean, free from dents, bends, rust and oil, and of adequate size as approved by the Engineer.

2.05 ROUND COLUMN FORMS.

- A. Structural quality fiberboard, metal tubes as specified for metal forms, or fibrous glass reinforced plastic.

2.06 METAL FORM TIES.

- A. Prefabricated rod, snap-off, or threaded internal disconnecting type of tensile strength to resist all imposed loads. Ties shall leave no metal within 12" of concrete surfaces after removal. Snap-off type ties shall have integral washer spreaders of diameter to fully close tie holes in forms. In waterbearing structures, ties shall be equipped with an integral waterstop, which shall remain in place.

2.07 FORM JOINT SEALERS.

- A. For joints between form panels, use resilient foam rubber strips, nonhardening plastic type caulking compound free of oil, or waterproof pressure-sensitive plastic tape of minimum 8-mil thickness and 2" width. For form tie holes, use rubber plugs, plastic caulking compound, or equal.

2.08 MOLDS.

- A. For grooves, drips, rebates, profiles, chamfers, and similar items, use smooth milled pine or douglas fir coated with specified form coating, or standard product extruded polymer plastic units of the indicated or required shapes.

PART 3 EXECUTION

3.01 FORM TYPES.

- A. Smooth Surface Concrete. Use specified plywood or metal forms, as approved, for interior and exterior exposed concrete and all formed concrete in contact with liquids, waterproofing and protective coatings. Metal forms shall be lined with plywood.
- B. General Concrete. Use either plywood or board forms for concealed surfaces, or form as specified for smooth surface concrete. Metal forms for general concrete need not be lined with plywood.
- C. Approval. Metal forms shall be furnished to the jobsite sufficiently in advance of construction for detailed inspection by the Engineer. Forms showing evidence of worn connections of tie-holes, damaged or warped surfaces, or any other unsatisfactory feature shall be ordered removed from the jobsite by the Contractor, and shall not be returned to the jobsite. Metal forms, faced forms, and other forms shall be maintained in good condition through the construction period, and when in the opinion of the Engineer this is no longer the case, the unsatisfactory material will be removed from the jobsite.
 - 1. Refer to Section 03300 for approval of form placement.

3.02 SHORING AND FALSEWORK.

- A. Distribute loads properly over base area on which shoring is erected, either concrete slabs or ground; if on ground, protect against undermining or settlement, particularly against wetting of soils.
- B. Alignment. Construct forms to produce in finished structure all lines, grades, and camber as required.
- C. Camber. Provide jacks, wedges, or similar means to induce camber and to take any settlement in formwork, which may occur either before or during placing of concrete.

Camber for beams and slabs shall be as and where indicated. Perform screening in such manner as to maintain beam depths and slab thicknesses.

3.03 FORM CONSTRUCTION.

- A. Build forms to exact shapes, sizes, lines, and dimensions as required to obtain accurate alignment, location and grades, and level and plumb work in finished structures. Provide for openings, offsets, keyways, recesses, moldings, reglets, chamfers, blocking, joint screeds, bulkheads, anchorages, and other required features. Make forms easily removable without hammering or prying against concrete. Use metal spreaders to provide accurate spreading of forms. Construct forms so that no sagging, leakage, or displacement occurs during and after pouring of concrete. Coat forms with specified coating material only prior to placement of reinforcing steel; do not allow coating to contact reinforcing bars. Provide 1-foot minimum clear opening over form for finishing concrete.
- B. Chamfers. Provide 3/4 inch x 3/4 inch chamfer strips for all exposed concrete corners and edges unless otherwise indicated.
- C. Recesses, Drips and Profiles. Provide types shown and required.
- D. Form Joints and Tie Holes. Seal joints between form panels with specified foam plastic strips, caulking compound, or tape. Unless form tie spreaders fully seal tie holes in forms, seal around ties with specified materials and prevent leakage of concrete mortar.
- E. Form Windows. Provide windows in forms wherever directed or necessary for access for concrete placement and vibration. Windows shall be of size adequate for tremies and vibrators, spaced at maximum 6 foot centers, horizontally. Windows shall be tightly closed and sealed before placing next lift of concrete.
- F. Cleanouts and Cleaning. Provide temporary openings in wall and column forms for cleaning and inspection. Prior to pouring, clean all forms and surfaces to receive concrete.
- G. Reglets and Rebates. Properly form all required reglets and rebates to receive flashing, frames, and other equipment. Dimensions, details, and precise positions of all such reglets and rebates shall be ascertained from the trades whose work is related to or contingent upon same, and the concrete work formed accordingly.
- H. Re-use. Clean and recondition form material before each re-use. Unsatisfactory material shall be rejected and removed from the site.

3.04 EMBEDDED PIPING AND ROUGH HARDWARE.

- A. All trades which require openings for the passage of pipes, conduits, and other inserts shall be consulted and the necessary pipe sleeves, anchors, or other required inserts shall be properly and accurately installed. Openings required by other trades shall be reinforced as indicated and required. Conduits or pipes shall be located so as not to reduce the strength of the construction, and in no case shall pipes other than conduits be placed in a slab 42" or less in thickness. Conduit embedded in a concrete slab shall not have an outside diameter greater than one-third of the thickness of the slab nor be placed below bottom reinforcing steel or over top reinforcing steel. Conduits may be embedded in walls provided they are not larger in outside diameter than one-third the thickness of the wall, are not spaced closer than three

diameters on center, and do not impair the strength of the structure. All conduit, piping and other wall penetrations or reinforcements shall be subject to Owner's policy and approval.

3.05 FIELD QUALITY CONTROL.

- A. Inspection of Forms. Refer to Article 3.01 C for approval requirements for forms prior to use, and to Article 3.05 B for requirements during concrete pours. Refer to Section 03300 "Cast-In-Place Concrete" for approval requirements for placement of forms.
- B. Control During Concrete Placement. Devices of the tell-tale type shall be installed on supported forms and elsewhere as required to detect formwork movements and deflection during concrete placement; plumb-bobs shall be utilized on forms for all walls and columns eight (8) feet or more in height. Required slab and beam cambers shall be checked and correctly maintained as concrete loads are applied on forms. Workmen shall be assigned to check forms during concrete placement and to promptly seal all mortar leaks.

3.06 REMOVAL OF FORMS AND SHORING.

- A. Do not remove forms or shoring until concrete has attained sufficient strength to support its own weight and all imposed construction and permanent loads. Any damage to the work resulting from early removal of forms or shoring or early imposed loading shall be corrected at no added expense to the District.

- B. Form Removal. Minimum times for removal after concrete placement are as follows:

Beam sides (but not shoring)	3 days
Column forms and wall forms	2 days
Forms for supported roof or floor slabs (but not shoring).....	14 days
Forms for slabs on grade.....	2 days

- C. Shoring and Falsework Removal. Do not remove shoring and falsework until twenty-one (21) days after concrete placement or until concrete has attained at least 90 percent of the twenty-eight (28) day design compressive strength as demonstrated by control test cylinders, whichever is earlier, but not sooner than fourteen (14) days.
- D. Restriction. Do not impose construction, equipment, or permanent loads on columns, supported slabs, or supported beams until concrete has attained the twenty-eight (28) day design compressive strength.
- E. Concrete Curing During Removals. Concrete shall be thoroughly wetted as soon as forms are first loosened and shall be kept wet during the removal operations and until curing media is applied. Potable water supply with hoses shall be ready at each removal location before removal operations are commenced. Contractor shall bear costs and delays caused by any damage resulting from early removal of forms or shoring. Refer to Section 03300, "Cast-In-Place Concrete" for curing requirements.

END OF SECTION

SECTION 03200

REINFORCING

PART 1 GENERAL

1.01 DESCRIPTION.

- A. Provide reinforcing work, complete as indicated, specified and required.
- B. Work Included in This Section. Principal items are:
 - 1. Furnishing and placing bar and mesh reinforcing for cast-in-place concrete including dowels for masonry work.
 - 2. Furnishing reinforcing steel bars for masonry, including delivery to the site.
- C. Related Work Not Included in This Section.
 - 1. Formwork (Section 03150).
 - 2. Cast-in-Place Concrete (Section 03300).

1.02 QUALITY ASSURANCE.

- A. Code Requirements. Unless otherwise specified, all work specified herein and as shown on the drawings shall conform to the applicable requirements of Chapter 26 of the Uniform Building Code, latest edition.
- B. Testing. Materials shall be tested as hereinafter specified and unless specified otherwise, all sampling and testing shall be performed by an Owner approved Testing Laboratory with cost borne by the Contractor.
 - 1. Test Samples. Bars, ties, and stirrups shall be selected by Testing Laboratory representative from material at the site or from place of distribution. Selection shall include at least two (2) pieces, each 18" long, of each sampling.
 - 2. Required Tests.
 - a. Identified Bars. Testing will not be required if reinforcement is taken from bundles as delivered from the mill, identified as to heat number and accompanied by certified mill analyses and certified mill test reports, and is properly tagged with Identification Certificate so as to be readily identified, unless otherwise directed by the Engineer.
 - b. Unidentified Bars. When positive identification cannot be made or when random samples are taken, tests shall be made from each five (5) tons or fraction thereof for each size. One tensile and one bend test shall be made from specimens of each size of reinforcement. Contractor shall bear costs and delays caused by testing unidentified bars.

- C. Standard. Reinforcing steel installations shall conform to the specification requirements of the Concrete Reinforcing Steel Institute "Manual of Standard Practice" (herein referred to as the CRSI Manual) except as otherwise indicated or specified.
- D. Field Quality Control. Continuous inspections, where required by the Special Conditions, shall be performed by the "Special Inspector" qualified and approved by Governing Building Code Authority or Inspector as otherwise qualified and approved by the Owner.
 - 1. Inspection of Reinforcing. Provide twenty-four (24) hour advance notice to permit inspection of in-place reinforcement prior to closing forms, and refer to applicable requirements of Section 03300, "Cast-In-Place Concrete".
 - 2. Concreting Operations. During concrete placing, assign construction personnel to inspect reinforcement and maintain bars in correct positions at each pour location.
 - 3. Welding Inspection. Where allowed, perform shop and field welding of reinforcing steel under continuous inspection of the Owner's Inspector or an Inspector representative of the Testing Laboratory approved by the Owner. Notify Owner at least twenty-four (24) hours in advance of any procedure involving the welding of reinforcement.

1.03 SUBMITTALS.

- A. Submit the following in advance of fabrication in conformance with applicable requirements of General Conditions.
- B. Shop Drawings. Submit six (6) sets of shop drawings for reinforcing steel prepared in accordance with ACI 315, "Manual of Standard Practice for Detailing Reinforced Concrete Structures". Show layouts, bending diagrams, assembly diagrams, dimensioned types and locations of all bar laps and splices, and shapes, dimensions, and details of bar reinforcing and accessories. Include layout plans for bar supports and chairs, with typical details. Owner's review shall be general, and acceptance will not relieve Contractor of responsibility for accuracy.
- C. Samples. Submit two (2) 12" long samples of each bar support and two (2) samples of each individual type chair, with catalog data.

PART 2 PRODUCTS

2.01 REINFORCING.

- A. Use deformed bars conforming to ASTM A615, Grade 60 Type "S". Where welding of reinforcing is required, use deformed bars conforming to ASTM A706 unless otherwise specifically designated on Drawings.

2.02 WELDED WIRE MESH.

- A. Conform to ASTM A185.

- 2.03 TIE WIRE.
- A. Annealed steel, 16 gage minimum.
- 2.04 COUPLER SPLICE DEVICES.
- A. Reinforcing bar coupler/splice devices which bear current I.C.B.O. Research Recommendation Approval, and which develop at least 125 percent of bar yield strength in tension may be used in lieu of lapped bar type splices. Submit for Owner's approval in each instance.
- 2.05 SUPPORTS AND ACCESSORIES.
- A. Use no aluminum, galvanized steel, plastic or stainless steel supports or accessories. Supports shall conform to CRSI Manual of Standard Practice, Chapter 3, for Types SB, BB, BC, JC, HC, CHC, and others of standard types as required, or precast concrete block supports (DOBIES) with embedded wire ties or dowels. Metal chairs shall be Class "1" plastic coated chairs and spacers.
- 2.06 DOWELS.
- A. Where and as designated on Structural Drawings, provide reinforcing bar dowels in new work and for anchorage to existing concrete.
- 2.07 FABRICATION AND DELIVERY.
- A. Conform to CRSI Manual Chapters 6 and 7 except as otherwise indicated or specified. Bundle reinforcement and tag with suitable identification to facilitate sorting and placing, and transport and store at site so as not to damage material. Keep a sufficient supply of tested, approved, and proper reinforcement at site to avoid delays.
- B. Bending and Forming. Fabricate bars of indicated size and accurately form to shapes and lengths indicated and required by methods not injurious to materials. Do not heat reinforcement for bending. Bars with kinks or bends not scheduled will be rejected. Field bend NO bars that are partially embedded in concrete, except as shown on the plans or specifically approved by the Engineer.
- C. Reinforcing Bars for Masonry. Bars shall be detailed and fabricated at the shop, ready for installation by masons.

PART 3 EXECUTION

- 3.01 PLACING.
- A. Unless otherwise indicated or specified, conform to CRSI Manual Chapter 8 including placement tolerances, except no reduction of concrete cover is allowable for bars at concrete surfaces exposed in liquid or water-containing structures.
- B. Cleaning. Before placing reinforcing, and again before concrete is placed, clean reinforcement of loose mill scale, oil, or other coating that might destroy or reduce bond. Do

- not allow form coatings, release agents, bond breaker, or curing compound to contact reinforcement.
- C. Concrete Coverage. Concrete coverage over reinforcing bars shall be as indicated on the Drawings. The coverage shall be to the outer edge of ties, stirrups, bar spacers, hangers, and like items, and the reinforcing shall be detailed and fabricated accordingly. Refer to Structural General Note requirements of the Drawings.
- D. Securing in Place. Accurately place reinforcement and securely wire tie in precise position at all points where bars cross. Tie stirrups to bars at both top and bottom. Bend ends of binding wires inward allowing no encroachment on the concrete cover; exercise special care at surfaces to remain exposed and unpainted. Support bars in accordance with CRSI Manual Chapter 3, Specifications for Placing Bar Supports, using approved chairs and supports. Ties or supports for reinforcing bars and mesh properly placed and tied into position are not to be removed or dislodged for the convenience of other crafts or for the purpose of crawl holes.
- E. Splices. Splices shall be wired contact lap splices unless otherwise indicated or approved. Splices shall conform to ACI 318, (Class A) (Class C) top bars and Typical Structural Details, except where lap length is indicated on the Drawings.
1. Vertical Bars. Splicing of vertical bars in concrete is not permitted except at the indicated or approved horizontal construction joints or as otherwise specifically detailed.
 2. Horizontal Bars. Unless otherwise shown, make lap splices with at least one continuous bar between adjacent splices. Splices in any one run of bar shall be spaced at least twenty (20) feet apart with splices in adjacent bars offset at least ten (10) feet. Where double mats of bars occur in walls, lap splices in opposite mats shall be offset at least five (5) feet.
- F. Welding. Welding of reinforcing bars is not permitted unless indicated or approved in each case, with continuous inspection as hereinbefore required. Welds for securing crossing bars are not allowed. Perform welding in shop or field by direct electric arc process, with thoroughly trained and experienced certified operators qualified in accordance with AWS Code. Conform all welding to AWS "Structural Welding Code - Reinforcing Steel". Use low-hydrogen electrodes. Welds shall develop at least 125 percent of the yield strength of the connected bars.
1. Preparation. Clean surfaces to be welded of loose scale and all foreign material. Clean welds each time electrode is changed. Chip burned edges clean before welds are deposited.
 2. Characteristics of Welds. When brushed with wire brushes, completed welds shall exhibit uniform section, smoothness of welded metal, feather edges without undercuts or overlays, freedom from porosity and clinkers, and good fusion with penetration into base metal. Cut out welds or parts of welds found defective with chisel and replace with proper workmanship; cutting torch for removing defective welding is not acceptable.
- G. Additional Reinforcing. Provide additional reinforcing bars at sleeves and openings as indicated or required. Where additional bars are not shown for such locations, obtain Engineer's instructions and provide additional bars as directed, at no extra cost to the Owner.

- H. Welded Wire Mesh. Install necessary supports and chairs to hold in place during concrete pours. Straighten mesh to lay in flat plane and bend mesh as shown or required to fit work. Laps shall be no less than one complete mesh unless otherwise detailed. Tie every other wire at laps.
- I. Dowels. For anchorage where shown or required to existing construction, use non-shrink epoxy type grout or deferred bolting devices as approved in each instance and conforming to "Product" Article requirements of Section 03300, "Cast-In-Place Concrete".
- J. Holes for epoxying dowels in place in existing concrete shall provide 2" minimum clearance on all sides of dowel bar.

END OF SECTION

SECTION 03300

CAST-IN-PLACE CONCRETE

PART 1 GENERAL

1.01 DESCRIPTION.

- A. Provide cast-in-place concrete work, complete as indicated, specified and required, including all appurtenant work as indicated.
- B. Work Included in This Section. Principal items are:
 - 1. All cast-in-place concrete including bases for mechanical and electrical equipment.
 - 2. Concrete standards, materials, mixes and tests, placement, finishing, patching, grouting, and crack repair.
 - 3. Embedded waterstops for cast-in-place concrete.
 - 4. Concrete curing.
 - 5. Sealing of joints in liquid-containing structures and elsewhere shown.
 - 6. Treatment of concrete surfaces.
- C. Related Work Not Included in This Section.
 - 1. Formwork (Section 03150).
 - 2. Reinforcing work (Section 03200).
 - 3. Concrete Unit Masonry (Section 04220).
 - 4. Architectural finishing
 - 5. Sealers, coatings, and waterproofing for treating concrete surfaces.
 - 6. Pre-stressed concrete.
- D. Definitions.
 - 1. Water-Bearing Structure shall be construed to mean any structure any part of which contains water or process liquids, or which protects spaces from groundwater.
 - 2. Definitions of surface treatments of concrete structures.
- E. Waterproofing. The Division 7 material to be applied, or the application of Division 7 material, to either earth-supporting below-grade surfaces or water-bearing surfaces of either

existing or new walls common to occupied areas (i.e. galleries, pump rooms, etc.), for the purpose of making such walls impervious to water or sewage.

- F. Damp-proofing. The Division 7 material to be applied, or the application of Division 7 material to either earth-supporting below-grade surfaces or water-bearing surfaces of either existing or new walls common to occupied areas (i.e. galleries, pump rooms, etc.), for the purpose of retarding the passage or absorption of water or water vapor. An alternate specified method of damp-proofing might be the addition of a suitable admixture or treated cement to the concrete.
- G. Coating. The Division 9 material or system, or application of Division 9 material or system, to protect or paint concrete surfaces.
- H. Sealer. A coating applied to seal the pores in an uncoated surface.
- I. The sealer for surfaces to be painted is the prime or first coat of a Division 9 painting system.
- J. The sealer for surfaces to be left unpainted is a clear transparent waterproof coating.
- K. Seal Coat. A layer of Division 2 bituminous material applied to seal the concrete surface.
- L. Sealant or Sealing Compound. A Division 7 impervious material for the purpose of excluding water by sealing or caulking joints in water-bearing surfaces or traffic surfaces, for the purpose of excluding moisture or sound by sealing or caulking joints in surfaces or partitions, or for the purpose of providing a bond breaker.

1.02 REFERENCE STANDARDS.

- A. Except herein modified, concrete work shall conform to the latest requirements/edition of ACI 301, Specifications for Structural Concrete for Buildings, and to requirements of ACI Standards and ACI Recommended Practices as contained therein.

1.03 SOURCE QUALITY CONTROL.

- A. Code Requirements. Unless more stringent requirements are specified herein and/or shown on the Drawings, all work shall conform to the applicable requirements of the Uniform Building Code, latest edition.
- B. Testing. Materials shall be tested as hereinafter specified and unless specified otherwise all sampling and testing shall be performed by Owner approved Testing Laboratory with cost borne by the Contractor.
 - 1. Portland Cement. Submit notarized Mill Certificates, provided by the cement manufacturer, including full compliance with requirements specified. In the absence of certificates, Testing Laboratory shall perform tests for each 250 barrels of cement at Contractor's expense, tests made in accordance with ASTM C150 with tensile strength test made at 7 days. Cement shall be tagged for identification at location of sampling.
 - 2. Stone Aggregate for Concrete. Test aggregate before and after concrete mix is established and whenever character or source of material is changed. Include a sieve analysis to determine conformity with limits of gradation. In accordance with ASTM C75, take

samples of aggregates at source of supply or at the ready-mix concrete plant. Submit certified test results.

- a. Sieve Analysis. ASTM C136.
 - b. Organic Impurities. ASTM C40. Fine aggregate shall develop a color not darker than reference standard color.
 - c. Soundness. ASTM C88. Loss resulting therefrom, after 5 cycles, shall not exceed 8% of coarse aggregate, 10% for fine aggregate.
 - d. Abrasion of Concrete Aggregate. ASTM C131; loss shall not exceed 10½% after 100 revolutions, 42% after 500 revolutions.
 - e. Deleterious Materials. ASTM C33.
 - f. Materials Finer Than 200 Sieve. ASTM C117; not to exceed 1% for gravel, 1.5% for crushed aggregate per ASTM C33.
 - g. Reactivity Potential. ASTM C289. Ratio of silica released to reduction in alkalinity shall not exceed 1.0.
- C. Applicator. The applicator of waterproofing, damp-proofing, coatings, sealers, seal coats, or sealants shall be approved by the manufacturer of the material.

1.04 CONCRETE MIX DESIGNS AND PRELIMINARY TESTS.

- A. At Contractor's expense, Testing Laboratory shall prepare mix designs for all cast-in-place concrete to have the required 28-day compressive strengths, and shall perform preliminary testing in accordance with the following requirements. Test results shall be submitted to the Owner. **Contractor may furnish mixes as specified in Part 2.02 in lieu of trial batches where appropriate.**
- B. Mix Designs.
1. Strength Requirements. Design concrete mixes for use in various locations, for minimum 28-day compressive strengths and maximum aggregate sizes required by Structural Drawings and these Specifications, as follows, except as otherwise specified in the Special Conditions:
 - a. 4,000 psi Concrete. 4000 psi concrete shall be provided throughout except as specified hereinafter, or in the Special Conditions.
 - b. 3,000 psi Concrete. 3,000 psi concrete shall be provided for concrete used in:
 1. all reinforced concrete, interior and exterior, not otherwise specified;
 2. anchors and anchor walls;
 3. pipe cradles, encasements, and beam supports;
 4. reinforced valve supports;
 5. concrete for grout topping (with reduced-sized aggregate as directed);
 6. paving;

7. sewer manhole bases and collars;
 8. sewer tree lateral clean-out supports;
 9. sewer chimney lateral supports.
 10. Non-machine laid curbs and gutters
 11. Spandrels
 12. Driveways and approaches
 13. Sidewalks
 14. Exterior slabs
 15. Stairs on grade
- c. 2,500 psi Concrete. 2,500 psi concrete shall be provided for non-reinforced concrete used in:
1. sewer overflow encasements;
 2. sewer lateral joint encasements;
 3. pipe joint mortar;
 4. fence post footings;
 5. non-reinforced cut-off walls;
- d. 2,000 psi Concrete. 2,000 psi concrete shall be provided for concrete used in:
1. non-reinforced thrust blocks and pipe pads;
 2. valve supports;
 3. sewer clean-out supports not otherwise specified.
2. Basis for Mix Designs. Design concrete mixes for workability of mix and durability of concrete. Concrete mixes shall be rigidly controlled in accordance with laboratory trial batch method or combinations of materials previously evaluated as required by Sections 5.3, respectively, Standard Building Code Requirements for Reinforced Concrete (ACI 318, latest edition), of the American Concrete Institute and to satisfy herein specified concrete strength requirements. When, in the opinion of the Engineer, it becomes necessary to increase the cement content to gain the required strength, such adjustment shall be made at the Contractor's expense.
3. Water/Cement Ratios. Mixes for normal weight aggregate concrete shall be designed within the following maximum water/cement ratios when concrete is to be used in the various locations:
- a. For 4,000 psi water-bearing structural concrete limit water/cement ratios by weight as follows:
 1. Freshwater-bearing structures 0.48 maximum
 2. Sewage-bearing structures 0.45 maximum

- b. For all other concrete, water/cement ratios shall be no greater than 0.53.
- C. Preliminary Strength Tests. In laboratory, prepare nine (9) compression test cylinders for each concrete mix design (unless more tests are required for an earlier age). Fabricate and cure cylinders in accordance with ASTM C31. Use concrete, aggregates and admixtures proposed for the concrete work. In accordance with ASTM C39, test three sets of two cylinders at 28-day age. For each mix, no individual strength test result shall fall below the required f_c' .
- D. Drying Shrinkage Tests. For each mix design used for preliminary strength tests, using same concrete materials including admixtures, prepare three (3) test specimens for drying shrinkage testing. Specimens shall be 4 inch by 4 inch by 11 inch prisms fabricated, cured, and tested in accordance with ASTM C157, using 10 inch effective gauge length. Measurements shall be taken at one (1) day, seven (7) days, fourteen (14) days and twenty-one (21) days of curing. Zero measurement shall be the one day reading when determining shrinkage. The measurements after 7, 14, and 21 days of drying shall be taken and reported separately. The average drying shrinkage of each set of test specimens after two (2) days of drying shall not exceed 0.036% for concrete in all portions of water-bearing structures and not exceed 0.05% for all other structural concrete, except concrete for footings, piles and pile caps will not require drying shrinkage tests. Single specimens shall be within a tolerance of 25% of said maximum percentage.
- E. Reports. File three (3) copies of each mix design, preliminary strength test report, and drying shrinkage test report with Owner for review and approval. Contractor shall submit a letter of certification by an approved testing laboratory that the concrete materials, mixes, properties, and work conform to the requirements indicated and specified.

1.05 PRODUCT DELIVERY, STORAGE, AND HANDLING.

- A. Deliver materials in a timely manner to insure uninterrupted progress of work. Store materials in a manner that will preclude damage and permit ready access for inspection and identification.
- B. Materials for treatment of concrete surfaces. The contractor shall deliver sealers, coatings, waterproofing, or other surface treatment materials to the site in their original, unopened containers with the manufacturer's labels intact, describing contents and manufacturer.
- C. Stored materials shall be kept covered and precautions shall be taken for the prevention of fire. Empty containers and soiled or oily rags shall be removed from the site at the end of each day's work.

1.06 PAYMENT.

- A. Payment for cast-in-place concrete shall be based upon concrete poured and found acceptable upon the removal of forms and performance of required finishing. Under no conditions will more than 90% payment be made for concrete formed and poured until required finishing is completed.
- B. On large structures requiring construction over multiple payment periods, consideration may be given by the Engineer for payment as follows:

- C. Forms and rebar in place and accepted for concrete pour - 50% maximum of concrete price per cubic yard.
- D. Concrete poured and forms stripped, and found acceptable to the stage of construction - 35% maximum of concrete price per cubic yard.
- E. Concrete finished and found acceptable - 15% of concrete price per cubic yard.

PART 2 PRODUCT

2.01 MATERIALS.

- A. Portland Cement. Standard brand of domestic Portland cement, ASTM C150, Type II, low alkali. Do not change brand of cement during progress of work without written approval of Engineer. For concrete exposed to sulfate-containing soils, solutions or other chemically aggressive solutions, use Type V Portland cement as specified.
- B. Normal Weight (Stone) Aggregates. Furnish natural aggregates from approved pits, free from opaline, chert, feldspar, mica (fools gold), siliceous magnesium limestone or other deleterious or reactive substances. Conform to ASTM C33 except as modified herein. Fine aggregates shall pass a #4 sieve. Do not use pozzolan or other additives to compensate for aggregate alkali reactivity.
 - 1. Coarse Aggregates. Clean, hard, fine-grained sound crushed rock or washed gravel which does not contain in excess of 5% in weight of flat, chip-like, thin, elongated, friable or laminated pieces, or more than 2% by weight of total amount of cherty material and soft particles, or more than 1% of chert as soft material as defined on Table 3 of ASTM C33. Consider any piece having a major dimension in excess of 5 times its average dimension to be flat or elongated.
 - 2. Maximum Sizes. As indicated on Drawings, except for concrete in water-bearing structures where coarse aggregate sizes per Table 2 of ASTM C33 shall be No. 467 (12 inches), No. 57 (1 inch), or No. 67 (3/4 inch) as otherwise required by design, specifications and ASTM C33, and except that coarse aggregate nominal maximum size shall not exceed one-fifth the narrowest dimension between sides of form, one-third the depth of slabs, or three-fourths of minimum clear spacing between reinforcing bars.
 - 3. Quality. All aggregates shall meet the test requirements of Article "Source Quality Control" hereinbefore.
 - 4. Abrasive Aggregate. "Alundum" by Norton Company, "Carborundum" by Union Carbide, or equal aluminum oxide, uniformly graded between No. 12 and No. 30 sieves, applied uniformly at minimum rate of 1/4 lb. per sq. ft. and locked into cement matrix with the final troweling.
- C. Admixtures. **Use one manufacturer's products throughout.** Upon Engineer's approval of use and of a particular brand or type, assure that use is reflected in mix designs. Approved manufactures are W.R. Grace and Master Builder Products.
 - 1. General. Use no admixture containing chlorides or triethanolamine. Admixtures used in combination shall be physically and chemically compatible and shall be so certified by each admix manufacturer and by Testing Laboratory that prepared respective mix

designs.

2. Retarding-Densifier Admixture. In all concrete use a hydroxylated carboxylic acid type admixture in the amounts recommended by the manufacturer. The admixture shall provide the following, and Contractor shall provide proof thereof at time of request for approval:
 - a. Decrease drying shrinkage.
 - b. Increase compressive strength at all ages up to and including five (5) years.
 - c. Increase flexural strength, modulus of elasticity, and abrasive resistance.
 - d. The water/cement ratio and required strengths shall be maintained as scheduled (cement factor for a cubic yard of concrete, reduced proportionately).
 - e. There shall be no loss of workability resulting from reduction in slump. If the admixture is of liquid type, it must be considered in proportioning water.
3. Air Entrainment. Use air entrainment additive conforming to ASTM C260 as approved by the Owner.
 - a. For normal weight aggregate concrete subject, after curing, to freezing temperature while wet shall contain air entrainment within limits of Table 4.2.1 of ACI 318, latest edition and Table 4.2.2.4 of ACI 301, latest edition.
 - b. Air Entrainment in Water-bearing Concrete Structures, as determined in accordance with ASTM C231 or C173, shall provide air contents as follows for mixes with the following coarse aggregate sizes:
 - 5% ± 1% for Size 467 (12 inch nominal size)
 - 6% ± 1% for Sizes 57 or 67 (1 inch or 3/4 inch nominal sizes)
- D. Water. Water shall be provided from a domestic potable source.
- E. Expansion Joint Material. Type I, preformed sponge neoprene expansion joint filler conforming to AASHTO Designation M-153.
- F. Bituminous Mastic. For fills at specific designated locations (such as fills at precast panel lift-eyes and dowel hole fills in precast concrete panels) use either Hot-Applied Type Joint Sealer, ASTM D1190 or Cold-Applied Type Joint Sealant, ASTM D1850. Material shall bond to concrete, prevent moisture infiltration and, when set, shall be non-tracking at summer temperatures.
- G. Waterstops. Waterstops shall be produced by an extrusion process in such a manner that any cross section shall be dense, homogeneous and free from porosity and other imperfections. They shall be symmetrical in cross-sectional shape and uniform along their length.

The manufacturer must certify in writing that all waterstops are extruded from elastomeric polyvinyl chloride compound and that this compound shall be virgin PVC compound and not contain any scrap or reprocessed materials whatsoever.

The manufacturer must also certify in writing that all waterstops meet or exceed the physical properties requirements set forth in the U.S. Corps of Engineers' CRD-C572-74 specification and furnish a copy of certified independent laboratory test data showing compliance.

All waterstop intersections (ells, tees, crosses, etc.) shall be fabricated by the manufacturer and these shall have 2 ft. long legs to facilitate field butt splicing. Where field dimensions are encountered which will not accommodate the specified waterstop, waterstop of reduced dimension may be approved by the Engineer for a specific application.

- H. Concrete Joint Sealants. For sealing joints in nonwater-bearing concrete surfaces, use materials conforming with requirements specified in Section 07920, "Sealants and Caulking". For sealing concrete joints which will be immersed or intermittently immersed in water or sewage-bearing surfaces, use: Karlee Company's "Lastex M" 100 percent solids polyurethane sealant; Mameco International's Vulkem 227, Vulkem 45, or Vulkem 245 contingent upon need for self-leveling, non-sag and atmospheric humidity at time of usage; Hunt's Seal Flex 227-U Special Reservoir Grade polyurethane sealant; or equal.
1. Primer. Use primer produced and/or recommended by sealant manufacturer.
 2. Back-up Preformed Joint Filler. Use closed-cell polyethylene foam or equal impervious, compatible, compressible foam material recommended for retaining sealant depth in expansion joints while curing. Use no bitumen or oil saturated material.
 3. Bond Breakers. Bond breakers, where required, shall be polyethylene tape or equal as recommended by sealant manufacturer to prevent adherence of sealant to back-up material.
- I. Dry Pack Mortar. Dry pack mortar shall consist of by volume one part special cement, three parts sand and water. The special cement and sand shall be combined in the proper proportions and then thoroughly mixed with the required amount of water. The dry pack mortar shall contain only enough water to permit placing and packing and shall be mixed for the time limit as indicated by the manufacturer in advance of use. The dry pack mortar shall be placed against thoroughly wet concrete and shall be cured by water, fog spray, spray-on membranes, sisal kraft paper, or other curing method acceptable to the Owner.
- J. Grout. Grout to be applied to the concrete surface shall consist of one part Portland Cement to three parts dry, washed sand to sufficient water to allow placement, screening, and finishing.
- K. Rich Grout. Rich grout shall consist of by volume one part Portland Cement, two parts sand and water. The rich grout shall be mixed and cured in the same manner as required for dry pack mortar.
- L. Neat Grout. Neat grout shall consist of Portland Cement, flyash, water and optional admixtures. Neat grout is intended to be injected under low pressure to backfill the annular space between steel casing pipes and carrier pipes.
- M. Nonshrink Grout. Nonshrink grout shall be made with the following proportions:
- One part Type II Portland Cement (one sack);
 - One part Nonshrink Aggregate (100 lbs.);
 - One part clean, well graded concrete sand (100 lbs.);
 - Approximately 5.5 gallons of water per sack of cement
1. In all locations where the surface of the grout will be exposed to view, the nonshrink grout shall be recessed approximately one-half inch back of the exposed surface and the recessed area filled with cement mortar grout.

- N. Nonshrink Concrete. All nonshrink concrete shall contain one pound of nonshrink aggregate per pound of water that is in excess of two gallons per sack of cement. Recess surface exposed to field as specified for nonshrink grout above.
- O. Nonshrink Aggregate. Nonshrink aggregate shall be non-metallic as produced by Master Builders, an equivalent product of Sonneborn, or a product by any other manufacturer that will meet the same ASTM requirements and equal performance.
- P. Epoxy. Epoxies for grouting, crack repair, patching, bonding or other uses shall be as follows as manufactured by Adhesive Engineering Company, Sika Chemical Company, or equal by other manufacturer. Throughout, use products of single manufacturer.
1. All epoxy mixing, surface preparation and application shall be made in conformance with manufacturer's printed specifications, as approved by the Engineer.
 2. For bonding new concrete to old concrete and for grouting metal anchors, use Sika's "Sikadur Hi-Mod", Adhesive Engineering Company's Concessive 1001-LPL, except Concessive 1170 or 1422 shall be used as recommended by manufacturer to satisfy entailed project temperature and surface moisture variations at time of application; or equal.
 3. For patching concrete surfaces, making high strength epoxy concrete or grout, and grouting metal anchors, use Sika's "Sikadur Hi-Mod LV"; Adhesive Engineering Company's "Concessive 1180"; or equal.
 4. For pressure injection or gravity-feed grouting, use Sika's "Hi-Mod LV"; Adhesive Engineering Company's "Concessive Structural Concrete Bonding Process System" as recommended by manufacturer and approved by Engineer; or equal.
- Q. Floor Hardener. Use hardened, non-metallic aggregate dust-on type floor hardener consisting of a single manufacturer's system equal to L. M. Scofield Company's natural gray "Lithochrome Hardener" applied uniformly at rate of 100 lbs. per 100 sq. ft. of floor space, or Master Builders' natural gray "Premixed Mastercron" applied at rate of one pound per sq. ft. of floor space. For use with air-entrained concrete, use Burke Company Non-metallic Floor Hardener Group Order #326 applied at a rate of 75 lbs. per 100 square feet. Burke Sparten Cote Cure-Seal-Hardener shall be used with Burke Non-Metallic Floor Hardener #326.
- R. Liquid Curing Compound. Use "TLF" or "Clear 225 TU" by Hunt Process Company, Burke "Rez-X", or equal conforming to ASTM C309 and providing no detrimental affects with deferred finishes. On surfaces within reservoirs or other concrete structures containing potable water, use nontoxic materials which are free of odor and taste. Provide supporting technical data. Floor hardener treated floors shall use materials only as recommended in writing by hardener manufacturer.
- S. Sheet Curing Materials. ASTM C171, waterproof paper, polyethylene film or white burlap-polyethylene sheet, non-staining.
- T. Vapor Barrier Membrane. Under interior on-grade slabs of occupied areas provide lapped and sealed vapor barrier membrane using Fortiber "Moistop", "Damproof XX" by Nicolet of California, Incorporated, or equal with manufacturer's recommended polyethylene pressure sensitive tape sealant used continuously at lapped joints, penetrations and at perimeter walls or footing surfaces. Throughout, use products and system of single manufacturer.
- U. Gasket Seal for Manhole and Wet Well Precast Concrete Members. Provide gasket seals at mating joint of precast concrete sections. Size gaskets to suit joint dimensions, surface conditions and to assure watertight completed installation. Seal shall consist of either

compressible closed-cell neoprene rods with compatible bonding agent recommended by material manufacturer; of No. 95 extruded butyl rod and No. 2 Primer each produced by General Sealants, Incorporated, City of Industry, California; or equal non-bituminous joint sealing compressible gaskets.

- V. Synthetic Sponge Rubber Filler. Synthetic rubber filler shall be an expanded closed-cell sponge rubber, manufactured from a synthetic polymer neoprene base. The material shall be No. 750.3 Ropax Road Stock as manufactured by the Presstite Division of Interchemical Corporation; Bondtex as manufactured by Rubatex Corporation; or approved equal. The size of the material shall be 25% greater in diameter than the nominal joint width. The manufacturer's instructions for surface preparation and application shall be used as a guide for installation, except that the material shall not be installed by stretching beyond its normal length.
- W. Expansion Joint Filler. Bituminous fiber expansion joint filler shall be in accordance with ASTM D1751. Bituminous expansion joint material shall not be used in joints to be sealed with synthetic rubber sealing compound.
- X. Concrete Expansion Bolts/Deferred Bolting Device (D.B.D.). Except as otherwise specified, where expansion bolts are called for on the Drawings, Parabolt Concrete Anchors as manufactured by the Molly Company, Kwik-Bolts as manufactured by McCulloch Industries, Incorporated, or a concrete anchor by any other manufacturer that shall meet the same Federal Specification requirements and shall equal the performance, shall be used. All bolts thus furnished and used on this project shall be manufactured of stainless steel.

2.02 CONCRETE MIXES.

- A. 28-Day Compressive Strength. It shall be the sole responsibility of the Contractor to mix, place, and cure concrete which shall be of 150 lb./cu. ft. nominal density and which shall attain the compressive strengths at 28 days as designated on Structural Drawings or in these specifications for use in various locations.
- B. Maximum Aggregate Size. Conform to Article 2.01 B.2. For 4,000 psi concrete use 1½ inch maximum size aggregate unless otherwise designated; for 3,000 psi concrete use 1 inch maximum size aggregate; for 2,500 and 2,000 psi concrete use ¾ inch maximum size aggregate. In no case shall the size of the coarse aggregate exceed 75% of the horizontal space between reinforcing bars or between reinforcing bars and forms.
- C. Mix Designs. Conform with requirements of Article 1.04 "Concrete Mix Designs and Preliminary Tests". At least 60 days before any Class concrete is to be placed, the Contractor shall submit for approval for each proposed mix a mix design made by a Civil Engineer registered in Nevada or a Testing Laboratory approved by the Owner.

2.03 CONCRETE MIXING. Concrete shall be ready-mixed, supplied from an off-site commercial ready-mix plant approved by Owner, each load accompanied by a bonded weigh-master's certificate listing the quantity of each concrete ingredient, admixture quantity, water content and slump, and time of loading and departure from ready-mix plant. Also include notations to indicate equipment was checked and found to be free of contaminants prior to batching.

- A. Ready-Mixed Concrete. Unless approved otherwise in advance of batching, all concrete of a single design mix for any one day's pour shall be from a single batch plant of a single supplier. Conform to ASTM C94, except materials, testing and mix design shall be as specified herein. Use transit mixers equipped with automatic devices for recording number of revolutions of drum.

All applicable mixing requirements specified herein for concrete mixed at the site shall govern transit-mixed concrete and the Owner shall have free access to the batching plant at all times. For concrete mixed in top-loading truck mixers, each batch shall be turned not less than 40 and not more than 300 revolutions of the mixer drum at mixing speed when the fine and coarse aggregate are charged into the mixer simultaneously (cement and water may be charged separately). When the fine and coarse aggregate are charged into the mixer separately, each batch shall be turned not less than 60 and not more than 300 revolutions of the drum at mixing speeds.

For concrete mixed in end-loading truck mixers, each batch shall be turned not less than 60 and not more than 300 revolutions of the mixer drum at mixing speed when the mixer is loaded in excess of 50 percent of the gross drum volume as provided hereinafter. When the mixer is loaded (not to exceed 50 percent of the gross drum volume) the provisions specified for top-loading truck mixers will apply.

Truck mixers shall be loaded in accordance with manufacturer's capacity ratings, but in no case shall the volume of mixed concrete exceed 50 percent of the gross volume of the drum for top-loading mixers and 58 percent of the gross volume of the drum for end-loading truck mixers.

Mixing speed shall be in accordance with manufacturer's recommendations, but in no case shall the speed be less than 4 revolutions per minute or greater than a speed resulting in a peripheral velocity of the drum of 225 feet per minute. The power unit shall be equipped with a governor to insure constant speed. Each truck mixer shall be equipped with a device for counting the number of revolutions of the drum, which device shall be interlocked so as to prevent the discharge of concrete from the drum before the required number of turns. After the drum is once started, it shall be revolved continuously until it has completely discharged its batch. Water shall not be admitted to the mix until the drum has started revolving. The right is reserved to increase the required minimum number of revolutions or to decrease the designated maximum number of revolutions allowed, if necessary, to obtain satisfactory mixing, and the Contractor will not be entitled to additional compensation because of such increase or decrease.

- B. **Mixing Water Limitations.** If water is added at the batching plant, ready-mixed concrete shall not be held in the mixer for more than one and one-half hours from the time the water is added. When temperature of concrete is 85°F or above, reduce holding time to 45 minutes. Do not deliver ready-mixed concrete to job with total specified amount of water incorporated therein. Withhold 2½ gallons of water per cubic yard, then incorporate in mix before concrete is discharged from mixer truck. If no water is added at the batching plant, measured quantities of water shall be added at the site and a minimum of fifteen minutes mixing given, or mixing to overcome segregation. Adding of water shall be under observation of Inspector. Each mixer truck shall arrive at the job site with its water container full. In event container is not full or concrete tests to a greater slump than specified, the load is subject to rejection.
- C. **Job Mixed Concrete.** Contractor shall obtain the approval of the Owner for equipment and procedures proposed for job mixed concrete.
- D. **Consistency and Slump.** Adjust quantity of water so concrete does not exceed maximum slumps specified when placed or specified water/cement ratio; use minimum necessary for workability required by the part of the structure being cast. Measure consistency of concrete in accordance with ASTM C143. Concrete exceeding maximum slump will be rejected.

Part of Structure	Maximum Slump
Footings and mass concrete not reinforced	3 inches

Slabs, and floors and reinforced footings	2 to 3 inches
Columns, walls over 8 inches thick	3 to 4 inches
Walls up to 8 inches thick	3½ to 4 inches
Equipment bases	3 to 5 inches

3.0 EXECUTION

3.01 PREPARATION BEFORE PLACING. Remove excess water from forms before concrete is deposited. Divert any flow of water without washing over freshly deposited concrete. Remove hardened concrete, debris, and foreign materials from interior of forms and from inner surfaces of mixing and conveying equipment.

A. Forms. Prior to placing concrete, forms shall meet the requirements of Section 03150, as approved by the Engineer. Concrete to be poured on earthwork such as slabs or stairs on grade shall meet the same requirements for approval prior to pouring as above specified for the approval of forms.

B. Reinforcement. Reinforcement shall have been secured under work of Sections 03150 and 03200, and inspected and approved. Embedded metal shall be free of old mortar, oils, mill scale, and other encrustations or coatings that might reduce bond. Wheeled concrete-handling equipment shall not be wheeled over reinforcing nor shall runways be supported on reinforcing.

"Break-out" bars or dowels bent for forming, for subsequent straightening prior to adjacent pour, will be allowed with bars of #5 maximum size, only where specifically called out on the Drawings, and only where kinks or breaks are not likely as a result of straightening. This does not imply approval of cold joints where none designed, or any deviation from construction joint requirements elsewhere in these specifications.

C. Wetting. Wet wood forms sufficiently to tighten up cracks. Wet other materials sufficiently to reduce suction and maintain concrete workability.

D. Earth Subgrade. Lightly dampened 24 hours in advance of concrete placing, but not muddied. Re-roll as necessary for smoothness, and remove all loose materials.

E. Aggregate Fill Base. Prepare same as earth subgrade. Center 30-mil plastic sheeting or roofing cap sheet on base course under indicated waterstop joints to retain mix fines within mix and prevent their percolation into base course.

3.02 WATERSTOPS. Heat fuse joints and connections in strict compliance with manufacturer's instructions including heating tools and devices. Waterstops shall be continuous in joints, following offsets and angles in joints until spliced to waterstops at intersecting joints, completely sealing the structure. Waterstops shall be aligned and centered in joints. Secure flanges of waterstops to reinforcing bars with 18 gage wire ties spaced maximum 18 inch center. All waterstops, splices, joints, intersections, and welds shall be tested with an approved holiday spark tester before concrete is placed. Locate waterstops where shown on drawings and in all water-bearing walls and slabs where common to: earth-bearing or earth-support; occupied areas; or above-grade exposed surfaces.

Waterstop shall be positioned correctly during installation and all splices in length or at intersections shall be performed by heat sealing and in accordance with manufacturer's recommendations.

Waterstop joints shall conform to Drawing requirements, if requirements are shown on the Drawings, and, whether or not requirements are shown on the Drawings, shall be properly heat-spliced at ends and crosses to preserve continuity. All splicing shall be done using mitered joints. Forms for construction joints shall be constructed in such manner as to prevent injury to waterstops. Waterstops shall be securely held in position in the construction joints by wire ties.

In narrow walls requiring both rebar and waterstop, the rebar shall be offset to one side and the keyway and/or waterstop shall be offset to the opposite side sufficiently to allow placement of both

rebar and waterstop without contact. In order to accommodate such an offset, double curtain steel may be replaced by one properly designed larger bar upon approval by the Engineer.

All in-place waterstop installations including locations and joints shall be approved by Owner prior to placement of concrete.

3.03 JOINTS IN CONCRETE. Locate joints in concrete where indicated unless otherwise approved. Obtain approval of points of stoppage of any pour, prior to scheduling of pour.

- A. Construction Joints. Unless otherwise shown, all construction joints shall be provided with suitable keyways of other keying methods. Clean and roughen contact surfaces of construction joints by removing entire surface and exposing clean aggregate solidly embedded in mortar matrix. Use mechanical chipping, sandblasting, or application of surface mortar retarder followed by washing and scrubbing with stiff broom. Cover and protect waterstops and other inserts from damage. The hardened concrete shall be watered and kept wet for at least 24 hours before placing new concrete. At construction joints not containing waterstops, the coarseness amplitude of the prepared surface shall be 1/4 inch minimum in accordance with the latest edition of ACI 318, Section 11.7.9. Provide sealant for construction joints where shown on the shop drawings and/or which will be immersed or intermittently immersed in water or sewage. Sealant shall be per Section 03300, Part 2, 2.01, H. Where construction joints are not indicated on the Drawings, provide slabs and walls with construction joints at intervals not greater than 30 feet.

Starter walls shall be used unless detailed otherwise. Where utilized, starter walls shall extend a minimum of 3 1/2 inches.

Where "break-out" bars are required by the contract drawings for future structure extensions, except where other methods are specifically set forth on the contract drawings a required mortar-tight enclosure of the reinforcing dowels shall be provided by installing the break-out bars in capped PVC pipe embedded 1 inch minimum into the structural concrete.

- B. Expansion Joints. Provide where indicated, 1/2 inch width unless otherwise detailed. Except where synthetic rubber (sealant) sealed joints are shown or specified, provide expansion joint filler and joint sealer, filler head down 1/2 inch to 3/4 inch and sealer finished flush with surface. At synthetic rubber sealed joints, hold filler down 1/2 inch unless otherwise shown, ready to receive sealant.
1. Location of joints in interior slabs on grade shall be as detailed on the Drawings. Sawed control joints shall be as approved by the Engineer.
 2. Control joints in exterior slabs shall be located as indicated on the Drawings, or as follows if not noted:
 - a. Provide bond breaker with 1/2 inch expansion joint material at junction of walls, bases, columns, etc.
 - b. Provide 1/2 inch expansion joints at changes in direction of slabs, or abrupt changes in width and not greater than twenty (20) feet apart on slabs without control joints.
 - c. Control joints in exterior slabs shall be sealed with the specified sealer.
- C. Roof and Floor Slabs. Pour slabs in alternating checkerboard fashion between indicated construction joints, as approved. Slabs in place shall be cured as required elsewhere in these specifications a minimum of seven (7) days before adjoining slabs are cast.

- D. Intermediate Screed Strips. Intermediate screed strips shall be required for all slab pours unless otherwise approved. Such approval for the omission of intermediate screeds shall be for each individual pour and no blanket approval shall be given.
- E. Gasket Seals. At joints between precast concrete manhole and/or wet well units, clean mating surfaces of both members. Then within groove, place and lay continuous rod of specified compressible gasket to provide watertight installation after placement of matching tongued concrete member and compression of the gasket.
- F. Joining Existing Structures. Where a construction joint to an existing structure requires a waterstop and none is found in the existing structure, Contractor shall join the old structure by chamfering the new concrete at the joint and filling the chamfer with specified epoxy sealant.

Where required reinforcing is not found protruding from the existing structure, required reinforcing shall be placed by drilling and placing dowels of the proper size and spacing.

Where required waterstop and reinforcing is found in the existing structure, joints shall be treated as other construction joints under Articles 3.01 and 3.02.

- G. Concrete for Buried Electrical. Buried electrical conduits shall be encased in concrete. Immediately after pouring concrete, red mineral oxide shall be evenly sprinkled on top of concrete to a minimum of 3/8" thick and then lightly raked into top of wet concrete encasement. Red coloring shall be pure mineral oxide, limeproof and nonfading. Amount and type of coloring agent used shall not reduce the quality of concrete below that specified.

3.04 CONVEYING AND PLACING CONCRETE.

- A. Do not pour concrete until reinforcing steel and forms have been inspected and approved. Notify Any concrete not in accordance with these specifications, out of line, level, or plumb; or showing cracks, rock pockets, voids, stalls, honeycombing, exposure of reinforcing, or any other damage which will be detrimental to the work will be considered defective and must be corrected and replaced as directed by the Engineer at no additional cost to the Owner. Any concrete work that is not formed as indicated; is not true within 1/250th of the span; is not true to intended alignment; is not plumb or level where so intended; is not true to intended grades and levels; has voids or honeycombs that have been cut, resurfaced or filled, unless under the direction of the Engineer; has any sawdust, shavings, wood or embedded debris; or does not fully conform to the contract provisions, shall be deemed to be defective and shall be removed from the site.
 - 1. Handle or pump no concrete utilizing aluminum equipment.
 - 2. Delivery tickets shall show the following:
 - a. Batch number.
 - b. Mix by compressive strength with maximum aggregate size.
 - c. Types and amount of admixtures included.
 - d. Air content.
 - e. Slump.
 - f. Time of loading and discharge.
 - g. Amount of water put in at batch plant.

- h. Location in the work.
 - i. Specification class of concrete.
 - j. Date of delivery.
3. If any water is added at the job site, it shall be approved by the Engineer and the delivery ticket noted as to the amount of water added. One copy of each delivery ticket shall be submitted daily to the Engineer.
- B. Weather. Do not place concrete during rain or freezing weather unless approved measures are taken to prevent damage to concrete. Concrete placed during periods of dry winds, low humidity, high temperatures, and other conditions causing rapid drying shall be initially cured with a fine fog spray of water applied immediately after finishing and maintained until final curing operations are started. Also under hot weather conditions, steps shall be taken to reduce concrete temperatures and water evaporation by proper attention to ingredients, production methods, handling, placing, protection, and curing.
- 1. Preventative measures taken for concrete placement during hot or cold weather shall be approved by the Engineer. There shall be no placing of concrete when ambient temperatures are below 35°F or above 100°F, or when such will be the case within 24 hours of the pour. Any concrete previously placed shall be protected from freezing.
- C. Conveying. Do not drop concrete from its point of release at mixer, hopper, tremies, or conveyances more than 6 feet, nor through reinforcing bars in a manner that causes segregation. Provide form windows, tremies, elephant trunks, and equivalent devices as required. The use of chutes for conveying or depositing concrete is not allowed except for small isolated portions of the work and only with prior approval. Deposit concrete directly into conveyances and from conveyances to final points of repose. Deposit concrete so that the surface is kept level throughout, a minimum being permitted to flow from one portion to another.
- D. Placing Concrete. Concrete shall be placed and compacted within 90 minutes after water is first added to the mix, and no concrete shall be placed after there is evidence of initial set. This placing time shall be reduced to 45 minutes when the temperature of the concrete is 85°F or above. Retempering of concrete is not allowed.
- 1. Horizontal Construction Joints. Horizontal surfaces of previously placed and hardened concrete shall be wet and covered with a 6 inch thick layer of concrete of the design mix with 50% of coarse aggregate omitted just before balance of concrete is placed.
 - 2. Lifts. Pour concrete into forms immediately after mixing in a manner that will prevent separation of ingredients. Except as interrupted by joints, all formed concrete shall be placed in continuous, approximately horizontal layers, the depths of which generally shall not exceed 18 inches.
 - a. Walls. Pour walls of water-containing structures, including tank exterior walls, as one continuous operation from footing to top of wall between indicated construction joints at the specified pour rate.
- Each section of wall shall be in place at least seven (7) days before the adjoining wall section is cast. Shear walls and columns within tanks and other walls may have horizontal construction joints at approved locations.

- b. Slabs. Pour slabs as one continuous operation between indicated or approved construction joints. Cure in-place slabs not less than seven (7) days prior to pouring alternate slabs. Then continue to cure until required curing time is attained.
 - c. Beams and Slabs. Pouring of all beams and slabs must be continuous and monolithic with the floor system where so shown on the Drawings. At least two (2) hours must elapse after depositing concrete in walls or columns before pouring beams, etc. supported thereon.
3. Pumping Concrete. No increase in the specified slumps will be allowed and required water/cement ratios shall be maintained for concrete pumping. Aluminum tubes are not acceptable for conveying concrete. Equipment shall be capable of maintaining the specified pour rates. Conform with requirements of ACI 304.2R-96, except as more stringent requirements are specified herein. Minimum conduit (tube) diameter shall be 4 inches.
4. Pour Rates.
- a. Vertical Elements. Place concrete in lifts as specified at a rate that does not overstress forms nor allows the top of a lift to begin to harden before the next lift is placed. Cold joints are not acceptable.
 - b. Slabs. Place concrete at a rate that ensures all deposits are joined to concrete that is still plastic and within 10 minutes of the previous pour. Concrete adjoining alternate slabs shall not be placed until the adjoining concrete has cured as required elsewhere in this specification for at least seven days unless otherwise approved by the Engineer.
5. Field Tests. During the progress of construction, the Owner will have tests made to determine whether the concrete, as being produced, complies with the standards of quality specified herein. These tests will be made in accordance with ASTM C31 and ASTM C39.

Each test will consist of a minimum of four cylinders, and the Owner, at his discretion, may take such tests as frequently as necessary to prove the quality of the concrete. In no case shall less than one test be made of each day's pour or of each 50 yards of concrete. The Contractor shall furnish the concrete for such tests but the remaining testing expense will be borne by the Owner. Specimens will be cured under job conditions.

For all concrete, the standard age of test will be 28 days, but the 7-day test may be used provided that the relation between the 7 and 28 strengths of the concrete is established by tests for the materials and proportions used.

Slump tests will be in accordance with ASTM C143.

Enforcement of Strength Requirement. Concrete is expected to reach a higher compressive strength than that indicated as minimum compressive strength. At least the specified minimum cement shall be used, and more cement shall be used, if necessary, to meet all minimum and maximum requirements shown in the table. Failure to meet these conditions shall be considered failure of the concrete.

One test shall consist of the results of testing three (3) standard specimens in accordance with ASTM C31 and C39, except that if one specimen in a test shows manifest evidence of improper sampling, molding, or testing, it shall be discarded and the remaining two strengths averaged. Should more than one specimen presenting a given test show defects due to improper sampling, molding, or testing, the entire test shall be discarded.

If the concrete fails to meet the specifications in the preceding paragraph, the Owner shall have the right to ask for additional curing of the affected portion followed by cores taken in accordance with ASTM C42 all at the Contractor's expense. If the additional curing does not bring the average of three cores taken in the affected area to at least the strength specified, the Owner may require strengthening of the affected portions of the structures by means of additional concrete or steel, or he may require replacement of these affected portions, all at the Contractor's expense. Core tests for below-strength concrete shall be paid for by the Contractor even though such core tests indicate the concrete has obtained the required minimum compressive strength.

- E. **Compaction.** Effective compaction shall be obtained by vibration, agitation, spading, and rodding until the concrete is free from voids, air bubbles, or rock pockets. Vibrators shall not be used to transport concrete within the forms. No less than one spare vibrator for each two vibrators in use on a pour, each in good working condition shall be kept on the job during pours. One ~~experienced~~ workman shall be assigned to the operation of each vibrator as his only duty. Operations not deemed to be satisfactory by the Owner shall be immediately corrected.
1. **Vibration.** All concrete, with the exception of concrete slabs 4 inches or less in depth, shall be compacted with high frequency, internal mechanical vibrating equipment supplemented by hand spading and tamping. Concrete slabs 4 inches or less in depth shall be consolidated by wood or metal grid tampers, spading and settling with a heavy leveling straight edge. Carefully vibrate concrete around waterstops and ensure the waterstops are not bent or damaged.
- a. **Vibrators.** Vibrators shall be designed to operate with vibratory element submerged in the concrete, and shall have a frequency of not less than 7,000 impulses per minute when submerged. The vibrating equipment shall be adequate at all times in number of units and power of each unit to consolidate the concrete to the maximum practicable density so that it is free from air pockets, honeycomb, entrapped air and so it closes snugly against all surfaces of forms and embedded items.
- b. **Operation of Vibrators.** Do not allow vibrators to contact forms or reinforcing. In vibrating a freshly placed layer of concrete, the vibrator shall be inserted vertically through the preceding layers that are still completely plastic and slowly withdrawn, producing the maximum obtainable density in the concrete without creating voids. Under no circumstances shall the vibrator enter or disturb concrete that has stiffened or partially set. The interval of vibrator placing shall not exceed two-thirds the effective visible vibration diameter of the submerged vibrator. Avoid excessive vibration that causes concrete segregation or causes an inordinate amount of entrained air to move to the face of the forms, which shall be causes for rejection of the concrete pour.
- c. **Re-Vibration of Retarded Concrete.** Concrete containing retarding admixture for structural walls and columns shall be placed by a schedule that allows each layer of concrete to be in place and compacted for at least 30 minutes before the next layer of concrete is placed. Bleed water on the surface of the concrete shall be removed before additional concrete is placed and the concrete in place re-vibrated before the next lift is placed. At tops of walls and columns concrete containing excess water or fine aggregate caused by vibration shall be removed while plastic, and the space filled with compacted concrete of the correct proportions, vibrated in place.
- F. **Slabs.** Set screeds at maximum 8 foot centers, as approved, and verify correct elevations with instrument level, and consideration for any camber in the form. Compact and tamp concrete to bring 3/8 inch mortar to surface, and wood float to straightedges and screeds. Make finished surfaces level or sloped as detailed, with maximum deviation of 1/4 inch from 10 feet straightedge for exposed finishes, and there shall be no low spots to impound water. Do not use steel or

plastic floats of any kind of initial floating operations. Unless otherwise specified, do not apply hereinafter specified finishes until surface water disappears and surface is sufficiently hardened. Remove all bleed water and laitance as it appears.

G. Tolerances.

1. Forms, sleeves, and inserts shall be set, and concrete shall be cast, to the lines and grades indicated on the plans and as detailed in these specifications. The maximum deviation from true line and grade shall not exceed the tolerances listed in the following table.

Item	Maximum Tolerance
Sleeves and inserts	+1/8 inch -1/8 inch
Projected ends of anchor bolts	+1/4 inch -0.0 inch
Anchor bolt setting	+1/16 inch -1/16 inch

2. Formed surface tolerances for concrete shall meet requirements for ACI surface classes as follows, unless otherwise specified herein or in the Special Provisions.

Class "A".	Exposed interior and exterior concrete to be coated or painted. Abrupt irregularities must meet a modified requirement of 1/16 inch maximum.*
Class "B".	Coarse textured concrete intended to receive plaster, stucco or wainscoting.
Class "C".	Exposed interior and exterior concrete not requiring coating or painting.
Class "D".	Permanently concealed surfaces below permanent ground level or operating water surface.

Permitted Irregularities in Formed Surfaces

Checked with a 5-foot Template.

Type of Irregularity	ACI Surface Tolerance Class of Surface			
	A	B	C	D
Gradual	1/8 inch	1/4 inch	2 inch	1 inch
Abrupt	*1/16 inch	1/4 inch	1/4 inch	1 inch

3. Deviation in alignment of slabs or walls shall not exceed a rate of 1/8 inch in 10 feet within the tolerances specified.
4. Slabs shall be uniformly sloped to drain.
5. Regardless of the tolerances listed herein, it shall be the responsibility of the Contractor to limit deviations in line and grade to tolerances which will permit proper installation and operation of mechanical equipment and piping.

3.05 CURING FORMED CONCRETE. Maintain forms containing concrete in a thoroughly wet condition until forms are removed. Maintain all concrete in a continuously moist condition for not less than 7

consecutive days after pouring (14 days on projects subject to Federal Wage Determination). Keep concrete moist with fine fog spray until protected by curing materials. Use water curing method, specified liquid membrane-forming compound, or concrete curing paper or mats, all subject to approval for each specific use. Vertical surfaces shall not be cured by sprinkling method unless specifically approved by the Engineer.

3.06 PLACING GROUT.

- A. Grout all steel bearing plates, columns, and other structural parts set to hardened concrete using nonshrink grout. Use an approved premixed grout, adding only water in the amount recommended by the manufacturer.
- B. Generally, use driest practicable mix and pack into place so no voids remain between steel and the supporting concrete.
- C. When necessary, use sufficient water to produce a flowable mixture, and pour, first forming sand dams to retain the grout until partially set. When sufficient set is attained, remove dams and pack grout to refusal on all four sides, to eliminate voids; fill any resulting edge voids with drier mix.
- D. In all locations where the surface of the grout will be exposed to view or in an area of high humidity, nonshrink grout shall be recessed to approximately one-half inch back of the exposed surface and the recessed area filled with cement mortar grout.

3.07 ANCHORS, SLEEVES, STAIR NOSINGS, ETC.

- A. Install in forms, in accordance with layout information provided by their suppliers, all necessary anchors, anchorage inserts, sleeves, slots, etc., required for fastening or passing the work of other Sections; also all such surface items as edge angles, manhole frames and other castings, trench cover frames or gratings, access panels, expansion joint covers, stair nosings, etc., having anchorage features requiring that they be installed before concrete is placed.
- B. All such items shall be accurately located, carefully plumbed and leveled, securely fastened in place so that alignment and level will not be disturbed during concreting, and protected from damage until concreting is completed.
- C. Provide all openings and chases in concrete, shown on the Drawings or as otherwise required.

3.08 EQUIPMENT BASES. Provide all concrete bases or foundations shown for equipment or fixtures included in other Sections of the work unless the Drawings or Specifications indicate that bases are to be furnished as part of the equipment.

- A. Material. In general, use 3,000 psi concrete as required by Article 1.04, unless otherwise specified on the Drawing.
- B. Installation of Nuts and Bolts. Work from approved setting Drawings. Use steel or plywood templates and apply nuts above and below, to hold bolts in vertical position. During the course of the placement of any concrete, the Contractor shall have sufficient personnel, of whatever skill or trade required, available to check the location of all embedded anchor bolts, edge angles for grating, or any other item which may be deemed appropriate by the Engineer. This check shall be made immediately after the work has progressed to a point such that the item shall not be subject to disturbance and prior to the concrete having obtained sufficient set such that adjustment of the items, if necessary, cannot be made with unacceptable damage to the concrete. If the operation is such that repeated checks are required, they shall be made.

- C. Size. Generally, the size indications and dimensions of bases shown on Drawings are approximate. The actual size, in all cases, shall be determined from the equipment furnished. Work from approved equipment supplier's drawings.

3.09 FINISHING FORMED CONCRETE.

- A. Within 5 days following the removal of forms, the following finishing operations shall be performed. No other finishing operations are required for permanently concealed concrete (i.e., concrete below permanent ground surface or operating water level). When specifically approved by the Engineer, finishing of concrete may be performed by units, (i.e. a complete wall, a complete structure, etc.), in which case 10% minimum concrete payment shall be retained for the finishing operation.

Finishing operations to be performed:

1. Remove projections and offsets.
2. Saturate form tie holes with water and fill voids with mortar of same mix as concrete (less coarse aggregate), cure and dry; white bonding glue manufactured for this purpose may be added to the mix in accordance with the manufacturer's instructions.
3. Patch all damaged areas due to spalling, voids, rock pockets and bleeding of cement (generally caused by form leaks) with mortar over a concrete adhesive bonding agent manufactured for this purpose and applied in accordance with the manufacturer's instructions. Cut out all rock pockets to sound concrete, edges square to the surface and back beveled, and patch with tempered mortar applied over an approved epoxy concrete adhesive. Large areas (as determined by the Engineer), and all other damaged areas over 1/2 inch in depth shall be repaired similarly. Other damaged areas less than 1/2 inch in depth shall be similarly repaired, but an approved white concrete bonding agent may be used in place of epoxy concrete adhesive.
4. Finish patches flush with adjoining surfaces and cure the same as the original concrete.

Attention is directed to the need for properly curing the repair patches, and for utilizing the proper bonding agent for a given situation (i.e., below operating water level). Information regarding the manufacturer's recommended use shall be furnished to the Engineer for his evaluation.

Pursuant to the specifications, all concrete must be cured for seven (7) days after pouring or patching, including sacked concrete, except concrete sacked after 7 days following pouring or patching needs no further curing.

5. Small air holes may be considered those which would be covered over by sacking, and need not be repaired on external walls being waterproofed or other areas not required to be sacked under the specifications. Air holes larger than this shall be considered voids.

Minor cement paste leaks are those not exposing aggregate and which can be covered over by sacking, and should be treated similarly to small air holes. Anything larger shall be considered a rock pocket or a bleed hole, depending upon the condition. Some small bleed holes may, at the discretion of the Engineer, not need to be chipped out, but may be merely sandblasted to sound concrete prior to patching.

- B. All exposed interior and exterior formed concrete (i.e., concrete not permanently concealed from direct visible exposure under facility operating conditions, including gallery and equipment room

walls and ceilings), and all concrete to be coated in the finished structure shall, in addition to the foregoing, be Brush-Off Blast Cleaned (SSPC-SP7-63) to open all paste and air holes and to remove curing compound and dust. It shall then be rubbed with cement of consistent color and burlap and/or with brick and water to eliminate pockets and produce reasonable smooth surfaces suitable for painting. A reasonable smooth surface shall be defined as a surface with no projections or form marks greater than 1/16 of an inch and no indentations after finishing. Chamfers and fillets shall be made straight and true, and uniform.

Concrete to be temporarily concealed until facility is expanded shall be considered exposed concrete.

3.10 FINISHING SLABS AND FLATWORK. As specified above, initially compact, bring 3/8 inch mortar to surface and float surfaces. Finished surfaces shall be "puddle-free" and level or sloped as indicated to above specified maximum deviation limits. Surfaces which are not within these limits shall be removed and replaced at no additional cost to Owner; patching is not acceptable. Keep surface moist with fine fog spray of water to prevent drying during finishing operations and until curing media is applied. Dusting with cement or sand during finishing operations is not permitted.

A. Precautions. Slabs have not been designed for heavy construction loads. Contractor shall repair or replace damaged slabs resulting from his use of heavy equipment or loadings as directed by the Engineer.

B. Rough Slabs. Broom surfaces of slab after initial set of concrete leaving coarse aggregate slightly exposed. Apply on following areas and surfaces:

1. Concrete to receive deferred concrete, grout or mortar.

2. Tops of footings for masonry.

C. Monolithic Trowel Finish. For all floor, slab, and flatwork surfaces not otherwise indicated or specified. After surface water disappears and floated surface is sufficiently hardened, steel trowel and re-trowel to smooth surface. After concrete has set enough to ring trowel, re-trowel to a smooth uniform finish free of trowel marks or other blemishes. Avoid excessive troweling that produces burnished areas.

D. Steel Float Finish. Same as monolithic trowel finish, except omit second re-troweling. Apply on following area and surfaces:

1. Apply on floor slab surfaces in water-bearing structures.

2. Areas scheduled to receive resilient floor coverings.

E. Swirl Non-Slip Finish. Prepare same as steel float finish, then perform final troweling with circular motion and slightly lift trowel to produce uniform swirl (sweat trowel) non-slip finishes matching sample selected by Owner from Contractor-prepared 2-foot square sample panels. Unless otherwise specified, provide uniform coarse texture on exterior walking surfaces.

F. Wood Float Finish. Float to screeds. When ready, finish with wood floats to a uniformly textured surface. Apply on following areas and surfaces:

1. Exterior walking surfaces exceeding 1:10 slope.

G. Floor Hardener Application.

1. Floor hardener shall be applied by dust-on method to all interior exposed concrete floors, and to other specifically designated floors using specified materials and rates of coverage.
2. Prior to application, the Contractor shall consult with the manufacturer's field representative in regard to application of floor hardener under prevailing job conditions.
3. Float and trowel floor hardener into the surface of freshly floated concrete floors shall be in strict accordance with the manufacturer's printed instructions.
4. Cure as work progresses using method conforming to hardener manufacturer's printed directions.

3.11 **CURING SLABS AND FLATWORK.** Apply curing media as soon as feasible after finishing operations without marring surfaces, and in any case on same day. Keep surfaces moist until curing is applied. Upon approval of liquid compounds, apply in strict accordance with material manufacturer's published application rates; apply two (2) spray coats, second coat sprayed at right angle direction from first coat. Carefully mask and protect adjoining surfaces where compound is used.

- A. **Curing Period and Protection.** Maintain curing materials in proper sealed condition for minimum of 7 days (14 days on projects subject to Federal Wage Determination) after application. Keep traffic on curing surfaces to the minimum possible, and completely off liquid compound cured surfaces. Immediately restore any damaged or defective curing media.
- B. **Restriction.** Do not use liquid membrane-forming curing compound within water-bearing structures, or on surfaces to receive deferred concrete or masonry, or on surfaces to receive fluid-applied protective coatings or waterproofing.
- C. **Liquid Membrane-Forming Curing Compound.** Upon approval, and except as restricted above, use liquid curing compound for all slabs, floors, and flatwork. On slabs having floor hardener treatment, cure such slabs in strict conformance with printed recommendations of floor hardener manufacturer. Other special precautions may be required if concrete is exposed to freezing or otherwise adverse weather conditions during the curing period.
- D. **Sheet Curing.** Use concrete curing sheet material on surfaces where liquid curing is not permitted, and on all joints sealed with pressure sensitive tape; immediately repair any tears during curing period. Verify that surfaces remain damp for full curing period; if necessary or directed, lift sheeting and wet surfaces with clean water, and replace sheeting.
- E. **Water Curing.** Alternate to either liquid curing compound or sheet curing method where approved. Keep concrete continuously wet by ponding, sprinklers, or equivalent for entire curing period.

3.12 **FORMED STAIRS AND TREADS.** Stair nosings are required on all stairs. Accurately place cast abrasive nosings and screed tread surface flush and level. Cut riser back as indicated. At exterior and wet interior locations, apply coarse textured swirl non-slip abrasive finish on surface of treads and landings. Strip protective tape from the nosings on completion of cement finishing operations.

3.13 **CHAMFERS AND FILLETS.** Unless otherwise shown on the drawings or directed by the Engineer, exposed edges of formed concrete structure shall be provided with a 45°, 3/4 inch x 3/4 inch chamfer. Where fillets are shown on the drawings, they shall be formed with a 45°, 3/4 inch x 3/4 inch form chamfer, formed with a 3/8 inch radius form, or tooled with a 3/4 inch radius rounding tool. Where project is an expansion of an existing facility, chamfer selected shall be compatible with chamfer of existing facility.

3.14 JOINTS WITH SEALANT. Sandblast joints to clean sound concrete, using oil-free air to provide surfaces free of oil, foreign materials, and moisture. Mix and place primer, and sealant in accordance with manufacturer's printed instructions. Install foam backing in joints so sealant depth is between one-half and two-thirds of joint width. Isolate backing from sealant using a bond breaker such as polyethylene tape, aluminum foil, or wax paper.

- A. Manufacturer's Supervision. A technical representative of the sealant manufacturer shall be present at the time sealant operations are started to supervise and approve preparation, sealant mixing, and sealant applications procedures and applicators. The representative shall make frequent visits to the site to ensure that sealant installations conform to the manufacturer's instructions, and shall issue a written report to Owner covering each visit.
- B. Crack Sealing. Before and after backfilling of the tanks, all cracks over 0.01 inch wide in concrete surfaces of tanks and other water-containing structures shall be cutout as detailed and the groove filled with backing, primer, and sealant.
- C. Joint Sealer. Unless specified otherwise, IGAS type joint sealer shall be used where joint depth is equal to or greater than twice the joint width. Colma type joint sealer shall be used where the depth to width ratio is less than 2:1.
- D. Sealant. All sealant shall be placed in strict accordance with the manufacturer's printed specifications by a firm specializing in this type of work for not less than five (5) years, or by the Contractor under direct supervision of the manufacturer's representative.
- E. Sealant Locations. All locations where sealant is placed must be cleaned by sandblasting and be free from oil, foreign materials, and moisture. Lower surfaces of joints shall be isolated with a bond breaker such as polyethylene, wax paper, aluminum foil or polyethylene tape.

3.15 INSTALLATION OF PIPELINES THROUGH CONCRETE STRUCTURES.

- A. Whenever a pipeline or any material terminates or extends at or through a structural wall or sump, the Contractor shall install in advance of pouring the concrete the fitting or special casting required for the particular installation. Otherwise, prepare and submit shop/erection drawings of other installation methods and obtain approvals in advance of commencement of work.
- B. Whenever any run of pipe is installed per approved shop/erection drawings subsequent to placing of concrete, the Contractor shall accurately position the opening in the concrete for such pipelines. Unless otherwise required, all pipes penetrating fluid containing or earth-supporting portions of the structure shall be ring flanged.
 - 1. Opening shall be of sufficient size to permit a perfect final alignment of pipelines and fittings without deflection of any part and to allow adequate space for satisfactory packing where pipe passes through wall to insure watertightness around openings so formed.
 - 2. The boxes or cores shall be provided with continuous keyways to hold the filling material in place and to insure a watertight joint.
 - 3. Boxes or cores shall be filled with nonshrink grout or nonshrink concrete.

3.16 FIELD QUALITY CONTROL.

- A. Concrete Tests. At Owner's expense, Owner's selected Testing Laboratory shall perform the concrete tests:
1. Compression Tests. Make one set of at least four standard test cylinders from each day's placing and each 150 cubic yards, or fraction thereof, each class of concrete. Date cylinder, number and tab, indicating location in structure from which sample was taken. Indicate slump test result of sample. Do not make more than one set of test cylinders from any one location or batch of concrete.
 2. Test Cylinders. Provide for testing by Owner or Testing Laboratory to take test cylinders at the job in accordance with ASTM C31. Test specimens in accordance with ASTM C39 at the age of 7 and 28 days. Contractor shall furnish labor and assistance for casting test cylinders, and shall furnish moist curing cabinets, as required, conforming to ASTM C31 at the site.
 3. Core Tests. Should strength of concrete, as indicated by tests, fall below required minimum, then additional tests of concrete which the unsatisfactory samples represent may be required by Owner. Testing Laboratory will make such test in accordance with ASTM C42. Contractor shall fill the holes made by cutting cores with dry pack concrete. Tests for below-strength concrete shall be paid for by the Contractor even though such tests indicate the concrete has obtained the required minimum compressive strength.
 4. Air Content. At time that compression test cylinders are cast, test a sample of the same concrete for air content in accordance with ASTM C231.

3.17 WATERTIGHTNESS OF CONCRETE STRUCTURES.

- A. All concrete structures designed to contain or convey fluid shall be tested for watertightness by the Contractor by filling with water to levels approximating what will be attained during operation and measuring the drop in level due to leakage, if any. These tests shall be made under the direction of the Owner, and if necessary, the tests shall be repeated until watertightness is insured.
- B. Rate of filling shall be limited to minimize shock-effect to new concrete construction. Water shall be held under each condition long enough to satisfy the Owner that the structures are watertight. Structures shall be free of internal or external water leakage.
- C. The total loss of water-level in any basin or flume shall not exceed 1/2 inch depth in 24 hours. Leakage shall be located and stopped and the structure again tested until this requirement is met. If the structure does not meet the test, the Contractor shall repair or replace at his own expense, such part of the work as may be necessary to secure the desired results, as approved by the Owner.
- D. Regardless of the rate of leakage, there shall be no visible leakage from any concrete structure.

- 3.18 ALTERATIONS AND REWORK. Existing concrete surfaces to receive new concrete shall be heavily sandblasted to expose coarse aggregate and produce clean coarse textured surface. Such prepared surfaces shall be coated with epoxy bonding compound immediately prior to placing concrete. The compound shall be an approved equivalent to Sika Chemical Company's "Sikastix Adhesive", Hunt Process Company's "HB Series Epoxy Mortar", or equal of type, mix and application in strict accordance with manufacturer's printed recommendations and directions for various conditions.

- 3.19 **QUALITY OF WORK.** Concrete work which is found to be in any way defective or out of tolerance may be ordered by the Owner to be removed and replaced. Should this occur, all costs shall be paid by the Contractor.

END OF SECTION

SECTION 03470

PRECAST CONCRETE VAULTS

PART 1 GENERAL

1.01 DESCRIPTION

- A. This section specifies the concrete work and appurtenances required for precast concrete vaults. Vaults shall be constructed of reinforced concrete sections and shall conform to the minimum dimensions shown on the Plans. Cast-in-place vaults will be considered acceptable only after approval is granted by the ENGINEER.

1.02 SUBMITTALS

- A. The CONTRACTOR shall submit to ENGINEER 4 sets of shop drawings showing size and placement of reinforcing steel, wall opening locations, etc., and structural calculations for the vault design sealed by a licensed Civil Engineer.
- B. The CONTRACTOR shall submit shop drawings of the proposed structure for review prior to construction. Drawings must provide information for complete review including dimensions, reinforcement design calculations and layout, etc.

PART 2 PRODUCTS

2.01 MATERIALS

A. Precast Concrete Sections

1. Precast sections shall be cast in a yard specializing in precast concrete materials.
2. All vaults shall be inspected during casting by an independent, certified testing laboratory, approved by the ENGINEER, to establish the strength of the concrete and the adequacy of curing, to certify the date the vaults were cast, and to confirm that the steel has been properly placed. This testing shall be performed by the laboratory at the CONTRACTOR's manufacturing plant, prior to shipment.
3. At least three cylinders shall be taken each day that vaults are cast, with batch samples to be designated by the laboratory representative. At least one set of cylinders shall be taken for each nine cubic yards of concrete used in the construction of the precast vaults. These samples shall be tested for strength. If the samples fail to meet minimum concrete strength requirements set forth in the Specifications, all vault sections manufactured from the concrete from which the cylinders were made will be considered rejected.
4. In addition, the OWNER reserves the right to core vaults either at the site or point of delivery to validate strength of concrete and placement of steel. If cores fail to demonstrate the required strength or indicate incorrect placement of reinforcing steel, all sections not previously tested will be considered rejected until sufficient additional cores

are tested, at the CONTRACTOR's expense, to substantiate conformance to these requirements.

B. Concrete

1. All concrete used in the construction of vaults shall be capable of obtaining a 28-day compressive strength of 4,000 psi.

C. Curing

1. All concrete shall be cured in accordance with any one of the methods specified in ASTM 478. The facilities for curing shall, however, be subject to the review and prior approval of the ENGINEER. No precast concrete shall be delivered to the job site until the specified minimum compressive strength of 4,000 psi, as determined by crushing tests on cured concrete cylinders, has been obtained.

D. Access Opening

1. The access opening shall be equipped with double leaf adjustable torsion spring assisted door as shown on the Plans.

E. Access Doors

1. Access door and frame shall be 1/4-inch steel diamond pattern. Door shall be equipped with heavy forged brass hinges, stainless steel pins, spring operators for easy operation and an automatic hold open arm with release handle. A snap lock with removable handle shall be provided. Cast in portion of frame shall be coated with bituminous paint prior to casting into concrete. Where double leaf doors are required, a safety chain shall be installed on the doors.

F. Joint Sealing Compound

1. Precast sections shall be jointed with a preformed joint sealing compound, "Ram-Nek", manufactured by K. T. Snyder Company, Inc., Houston, Texas, "Quikset" manufactured by Quikset Utility Vaults, Santa Ana, California, or equal, applied in accordance with the manufacturer's instructions.

PART 3 EXECUTION

3.01 INSTALLATION

A. Transportation and Delivery

1. Every precaution shall be taken to prevent injury to the precast sections during the transportation and unloading of the sections. The precast sections shall be unloaded using skids, pipe hooks, rope slings, or suitable power equipment, if necessary and the sections shall be under perfect control at all times. Under no conditions shall the precast sections be dropped, dumped or dragged.

2. If any precast section is damaged in the process of transportation, or handling, such section shall be rejected and immediately removed from the site and replaced at the CONTRACTOR's expense.
- B. Excavation and Backfill
1. Excavation and backfill shall be done in accordance with the provisions of Section 02200 of these specifications and the Plans.
- C. Joint Sealing Compound
1. The sealing compound shall be applied as follows:
 2. The joint shall be cleaned with a brush.
 3. The Silicon treated protective paper shall be removed from one side of the preformed rope and preformed rope shall be laid paper side up on the cleaned joint surface. The surface shall be pressed firmly end-to-end around the entire joint making 1-inch laps where necessary.
 4. The protective paper shall be removed from the preformed rope and the next section shall be lowered into place.
 5. Sufficient preformed joint sealing compound shall be installed so as to completely fill the joint and show a "squeeze-out" on the inside and outside of the joint.
- D. Pipe and Fittings
1. All pipe and fittings, including installation shall conform to the provisions of the specifications of the designated pipe and fittings.
- E. Pipe Penetrations
1. The pipe penetrations shall incorporate Link Seal assemblies, Model C LS 575 with WS-18-375 Steel Sleeve as per the Plans.
- F. Elevation and Installation
1. Each section shall be set perfectly plumb. Riser sections of various heights shall be used in order to bring the top of the vault access opening to the required elevation.
 2. The elevations at which access openings are to be set shall conform to the requirements set forth on the Plans, but in all cases shall be governed by the ENGINEER in the field. Where the access opening is within the roadway or shoulder, it is to be placed flush with the existing surface. Where the structure is outside the limits of the traveled shoulder, but not in roadside ditch, it should be placed 1/10 foot or more above the existing ground surface. Where the access opening falls within the existing roadside ditch or right of way, it is to be placed approximately 1-1/2 feet above the existing ground surface or as directed by the ENGINEER.

G. Concrete Finish

- a. Concrete walls, roof and floor shall have surface defects repaired and have a minimum rough form finish as specified in the ACI (American Concrete Institute) Manual of Concrete Practice Section 301, Chapters 9 and 10.

H. Cleaning

1. Vaults walls, floor and ceiling shall be cleaned of any foreign debris, including forms, tape, form oil, etc., prior to final acceptance. All vaults shall be thoroughly cleaned of any accumulation of silt, debris, or foreign matter of any kind.
2. Access openings shall be cleaned of foreign matter to insure a satisfactory fit and appearance prior to final acceptance.

I. Testing

1. It is the intent of the Plans and Specifications that vaults be as watertight and free from infiltration as possible. Any evidence of leakage throughout the warranty period shall be repaired to the satisfaction of the OWNER at the sole expense of the CONTRACTOR.

END OF SECTION

SECTION 11206
LIFT STATION FLOW METER AND GAUGES

PART 1 GENERAL

1.01 DESCRIPTION

A. Description of Work

It is the intent to provide flow meters and gauges of the same type and manufacturer as used at the various project locations.

B. Flow Meter: Provide a 4-inch magnetic flow meter **and install the meter at the force main discharge located at the wastewater treatment plant site.**

C. Gauges: Install a pressure gauge on the sewage force main within the valve vault as shown on the plans.

1.01 RELATED SECTIONS

A. Section 02625 Pressure Pipe-Valves-and Fittings

1.02 REFERENCES

A. ISA – Instrument Society of America

B. ANSI/ISA S5.1 – Instrumentation Symbols and Identification

C. NEMA – National Electrical Manufacturers' Association

D. ASME – American Society of Mechanical Engineers

E. NEC – National Electrical Code

F. OSHA – Occupational Safety and Health Administration

1.03 SUBMITTALS

A. Furnish shop drawing submittals in accordance with Section 01300 Contractor Submittals.

PART 2 PRODUCTS

2.01 GENERAL

A. Instrumentation work shall conform to or exceed the applicable requirements of the National Electrical Code.

B. Instruments shall be the most recent field-proven models marketed by their manufacturers at the time of submittal of the Shop Drawings unless otherwise required.

2.02 MAGNETIC FLOW METER

A. Magnetic Flow Meter:

1. Provide a 4-inch Endress+Hauser, Inc., Model Proline Promag E100 magnetic type flow meter with local flow indication and provisions for a high resolution signal to a SCADA system by others.

2. Provide meter with a polyurethane liner, ANSI B16.5 flanged ends, 316 SS electrodes, and includes 0.5% calibration

3. Meter shall include a Nema 4X housing and require a 24VDC power supply, output of the meter shall be 4-20mA based on full scale range.
4. Meter to include grounding rings mounted in each end of the meter. Grounding rings are not required if the internal potable coatings have been removed.
5. Meter output shall be displayed locally with provisions to be transmitted to a SCADA system, by others. Coordinate with the OWNERS electrical and SCADA contractors. The SCADA system is based on Modicon PLCs and Modbus TCP protocol.
6. Install flow meter on the sewage force main at the wastewater treatment plant, as shown on the drawings.
7. Provide meter with a flow range of 0 to 400 gpm.

2.03 PRESSURE GAUGES:

- A. All gauges shall be a minimum of 4" diameter, standard bourdon tube-style oil (glycerin)-filled pressure gages, brass connection port, stainless steel case and bayonet ring and be in accordance with ASME B40-100, grade 1A.
- B. Provide diaphragm seals to isolate gages from the process fluid. Fill fluid shall be ethylene glycol or silicone oil.
- C. Provide a stainless steel ball valves for isolation of gage.
- D. Gauge accuracy shall be +/- 1% of span throughout the full range. Gauges shall be selected to read at mid-point when operating at design conditions.
- E. Gauge operating temperature shall be -40°F to 140°F (-40-+60°C) ambient and +140°F (+60°C) fluid medium maximum.
- F. Pressure Range: Provide a 0 to 60 psi pressure range.

PART 3 EXECUTION

3.01 PRODUCT HANDLING

- A. Shipping Precautions: Instruments shall be packed and secured to provide complete protections from damage, dust and moisture.
- B. Special Instructions: Special instructions for proper field handling, storage, and installation required by the manufacturer shall be securely attached to each piece of instrument prior to packaging and shipment.
- C. Storage: Instruments shall be stored in dry permanent shelters and shall be adequately protected against mechanical injury. If any apparatus has been damaged, such damage shall be repaired by the Contractor.

3.02 MANUFACTURER'S SERVICES

- A. Contractor shall ensure or may need to furnish some or all of the manufacturer's services for the instrumentation listed in this specification:
 1. Perform factory bench calibration
 2. Oversee installation
 3. Verify installation of installed instrument

4. Site verification of calibration.

3.03 INSTALLATION

A. General

1. Contractor shall install instrumentation per manufacturers' instructions.
2. Instrument Locations: The locations of instruments are approximate. The exact locations and routing of wiring and cables shall be governed by structural conditions and physical interferences. Instruments shall be located and installed so that it will be readily accessible for operation and maintenance. Where job conditions require reasonable changes in approximated locations and arrangements, or when the Owner exercises the right to require changes in locations of equipment which do no impact material quantities or cause material rework, the Contractor shall make such changes without additional cost to the Owner.

B. Conduit, Cables, and Field Wiring

1. Conduit shall be provided in timely matter without delay to the Work.
2. All field wiring and cables shall be provided in timely matter.

C. Instrumentation Tie-Downs: Instruments shall be anchored by methods that comply with seismic requirement applicable to the Site.

D. The Contractor shall be responsible for providing any additional or different type connections as required by the instruments and specific installation requirements. Such additions and such changes, including the proposed method of installation, shall be submitted to the Engineer for approval prior to commencing the work. Such changes shall not be a basis of claims for extra work or delay.

E. Installation Criteria and Validation: Field-mounted components and assemblies shall be installed and connected according to the requirements below:

1. Installation personnel have been instructed on manufacturers' installation requirements.
2. Technical assistance is available to installation personnel at least by telephone.
3. Installation personnel have one copy of the approved Drawings and data.
4. Power and signal wires shall be terminated with crimp type lugs, where the terminal block requires this.
5. Connectors shall be, as a minimum, water tight.
6. Wires shall be mounted clearly with an identification tag that is of a permanent and reusable nature.
7. Wire and cable shall be arranged in a neat manner and securely supported in cable groups and connected without splices unless specifically approved by the Engineer. Wiring shall be protected from sharp edges and corners.

F. Verify the correctness of each installation, including polarity of electric power and signal connections, and make sure process connections are free of leaks.

3.04 CALIBRATION

- #### A. General: Devices provided shall be calibrated according to the manufacturer's recommended procedures to verify operation readiness and ability to meet the indicated functional and tolerance requirements.

- B. Calibration Points: When possible each instrument shall be calibrated at 5, 50, and 90 percent of span using test instruments to simulate inputs. The test instruments shall have accuracies traceable to National Institute of Standards and Testing.
- C. Bench Calibration: Instruments that have been bench-calibrated shall be examined in the field to determine whether any of the calibrations are in need of adjustment.
- D. Field Calibration: Instruments which were not bench-calibrated shall be calibrated in the field to insure proper operation in accordance with the instrument data sheets.

3.05 PERFORMANCE TEST

- A. All instruments shall operate for 30 days without failure.
- B. The Contractor shall furnish support staff as required to satisfy the repair or replacement requirements.
- C. If any component fails during the performance test, it shall be repaired or replaced.

3.06 ACCEPTANCE

- A. The following conditions shall be fulfilled before the WORK is considered substantially complete:
 - 1. Submittals have been completed and approved.
 - 2. The instruments have been calibrated.
 - 3. Any necessary training has been performed.
 - 4. Spare parts and expendable supplies and test equipment have been delivered.
 - 5. The performance test has been successfully completed.
 - 6. Record drawings have been submitted.

*****END OF SECTION*****

SECTION 11311

SUBMERSIBLE SEWAGE PUMPS AND WET WELL

PART 1 GENERAL

1.01 DESCRIPTION

The work covered in this Section includes furnishing of all related materials, installation, and testing of the Flygt pre-engineered pump station package that will serve as the wet well. The pre-engineered pump station package, including submersible pumps, pump control, fiberglass wet well, internal piping, accessories and auxiliary equipment shall be supplied by the pump manufacturer.

1.02 SUBMITTALS

- A. Pre-engineered Pump Station Package: Material certifications stating conformance with the requirements of this Section.
- B. Submittal shall be delivered to Engineer in accordance with Section 01300 - Submittals of the Technical Specifications.

1.03 REFERENCES

- A. ASTM A 48 - Standard Specification for Gray Iron Castings
- B. ASTM A479 – Standard Specification for Stainless Steel Bars

1.04 DESIGN REQUIREMENTS

A. General:

The TOP pre-engineered fiberglass pump station package shall be capable of handling unscreened sewage, wastewater or storm water in accordance with the design conditions defined in this specification.

The fiberglass pump station shall have an integral, hopper-shaped pump station bottom, which is self-cleaning by virtue of its design. The flat surface area shall be minimized to an area that is directly influenced by the pump suction and shall be free of obstacles. The bottom surface area shall have a ratio of 1:4 as it relates to the cross-sectional area of the pump station. The sloping walls of the pump station bottom shall further optimize the self-cleaning features of this station by directing all solids, trash and sludge, normally found in sewage and wastewater, to the suction of the submersible pumps to facilitate removal and effectively clean the bottom.

Furnish and install 2 Flygt Model NP 3153 HT 3 464 - 253 mm impeller submersible non-clog wastewater pumps suitable for pumping raw sewage. Each pump shall be equipped with a 15 HP 1800 RPM submersible electric motor, connected for operation on a 480 volt, 3 phase, 60 hertz, three wire service, with 50 feet of submersible cable (SUBCAB), suitable for submersible pump applications. The power cable shall be sized according to NEC and ICEA standards and have P-MSHA Approval. The pump shall be supplied with a mating cast iron inch discharge connection and be capable of delivering 287 GPM at 87 ft. TDH and secondary point at 180 GPM at 95 ft. TDH. Pump efficiency shall be 50% or better at these operating points.

Each pump shall be fitted with 25 feet of lifting chain or stainless steel cable. The working load of the lifting system shall be 50% greater than the pump unit weight.

1.05 DELIVERY, STORAGE, AND HANDLING

- A. Delivery, storage, and handling of pre-engineered lift station shall be conducted in a manner that prevents damage to the structure.

PART 2 MATERIALS

2.01 LIFT STATION STRUCTURE

- A. The cylinder shall be made of FRP using the filament winding process. A safety factor of two (2) on the minimum ultimate tensile strength of the laminate bottom shall be used in designing the basin and cylinder wall thicknesses for the station, taking into account all normally imposed loads arising from flotation, soil pressures, normal backfill, handling loads, operating loads and static loads imposed by equipment used in hoisting the pumps in and out of the station.
- B. The station cylinder shall be affixed to the station bottom such that the assembled components are structurally integrated, resulting in a watertight vessel which is capable of withstanding the full hydrostatic head from the exterior of the station while the station is completely empty.
- C. The cylinder is a filament wound laminate constructed by saturating continuous strand glass roving in a controlled pattern over a corrosion resistant liner that is to be 110 mils minimum thickness. The roving's shall be applied uniformly throughout the entire length of the cylinder as required to provide adequate thickness for the mechanical loads of each application. The winding pattern shall be a combination of helical and hoop wraps and shall produce a dense laminate without non-reinforced resin pockets or air bridging between the rovings. The glass content of the structural laminate shall be 60% to 70% by weight.
- D. The station bottom is a 30% to 50% glass content, chop spray laminate, constructed by built-up layers of chop spray and woven roving applied along with a catalyzed isophthalic resin. Each layer shall be properly wetted out and rolled out so that it is free of air voids until the required wall thickness has been obtained.
- E. All inside surfaces shall be smooth and free of cracks and crazing. The inside surface will be pigmented or gel coated to a bright white finish. All surfaces other than those made in contact with the mold surface shall be coated with air-inhibited resin or gel coat; this includes any cut edges of laminate.
- F. The station shall be provided with one (1) anti-flotation flange located near the bottom of the station. This anti-flotation flange is an integral part of the station and is sufficient in design to withstand the forces acting upon the station due to the subsoil water pressure. Once the station is inserted into the hole, concrete ballast may be required depending on the station depth, please refer to the recommendations for concrete ballast as recommended in Flygt's TOP Station Operations and Maintenance manual. The combination of the flange and the loading of backfill material over the concrete shall provide adequate ballast against buoyancy under full hydrostatic head conditions.

2.02 LIFT STATION COVER

- A. The TOP station cover shall be of 1/4-inch thick Type-5086 aluminum diamond plate with an integral Safe-Hatch access cover. All bars, angles and shapes shall be type 6061-T6 aluminum. The access cover frame shall be a minimum of 4-inches deep and shall be adequately sized to allow for easy passage of the submersible pumps. The Safe-Hatch access cover shall be designed to support the weight of the pump unit plus pedestrian traffic. The access door(s) shall be equipped with a hold-open arm, held open in the 90-degree position. Cover door hinges shall be heavy-duty design and be cast 1/4-inch thick Type 316 stainless steel with 3/8-inch diameter stainless steel hinge pins. All fasteners shall be type-316 stainless steel. Each hatch shall be supplied with a type-316 stainless steel slam lock, having a key-way protected by a threaded plug. The plug shall be flush with the diamond plate cover. The hatch shall be equipped with an aluminum lift handle that shall be flush to the top of the diamond plate cover.
- B. The station lid shall have an integral four-inch diameter stub-pipe connection for the purpose of venting the pump station. The inverted J-shaped vent pipe shall be schedule 40 PVC pipe and shall end at a point at least 3-foot above the elevation of the station cover. There shall also be an option for a second vent to accommodate positive ventilation of the wet well.
- C. The access cover unit shall be equipped with a Safe-Hatch hinged safety grate to provide protection against fall-through and to control access into the confined space. Grate openings shall be sized to allow for routine maintenance inspection without having to open the safety grate. The closed safety grate shall be designed to support the weight of one pump to facilitate site pump wash-down and inspection. The hatch opening will have a 4" elevated toe board to prevent tools from being kicked into the wet well (per OSHA 1926.502 (j)).

2.03 PUMP HOUSING

- A. Major pump components shall be of grey cast iron, ASTM A-48, Class 35B, with smooth surfaces devoid of blow holes or other irregularities. All exposed nuts or bolts shall be AISI type 304 stainless steel construction. All metal surfaces coming into contact with the sewage, other than stainless steel or brass, shall be protected by a factory applied spray coating of acrylic dispersion zinc phosphate primer with a polyester resin paint finish on the exterior of the pump.
- B. Sealing design shall incorporate metal-to-metal contact between machined surfaces. Critical mating surfaces where watertight sealing is required shall be machined and fitted with Nitrile O-rings. Fittings will be the result of controlled compression of rubber O-rings in two planes and O-ring contact of four sides without the requirement of a specific torque limit.
- C. Rectangular cross sectioned gaskets requiring specific torque limits to achieve compression shall not be considered as adequate or equal. No secondary sealing compounds, elliptical O-rings, grease or other devices shall be used.

2.04 PUMP MOTOR

- A. The pump motor shall be a NEMA B design, induction type with a squirrel cage rotor, shell type design, housed in an air filled, watertight chamber. The stator windings shall be insulated with moisture resistant Class H insulation rated for 180°C (356°F). The stator shall be insulated by the trickle impregnation method using Class H monomer-free polyester resin resulting in a winding fill factor of at least 95%. The motor shall be inverter duty rated in accordance with NEMA MG1, Part 31. The stator shall be heat-shrink fitted into the cast iron stator housing. The use of multiple step dip and bake-type stator insulation process is not acceptable. The use of pins, bolts, screws or other fastening devices used to locate or hold the stator and that penetrate the stator housing are not acceptable. The motor shall be designed for continuous duty while handling pumped media of up to 104°F. The motor shall be capable of no less than 30 evenly spaced starts per hour. The rotor bars and short circuit rings shall be made of aluminum. Three thermal switches shall be embedded in the stator end coils, one per phase winding, to monitor the stator temperature. These thermal switches shall be used in conjunction with and supplemental to external motor overload protection and shall be connected to the motor control panel.

The junction chamber shall be sealed off from the stator housing and shall contain a terminal board for connection of power and pilot sensor cables using threaded compression type terminals. The use of wire nuts or crimp-type connectors is not acceptable. The motor and the pump shall be produced by the same manufacturer.

The motor service factor (combined effect of voltage, frequency and specific gravity) shall be 1.15. The motor shall have a voltage tolerance of +/- 10%. The motor shall be designed for continuous operation in up to a 40°C ambient and shall have a NEMA Class B maximum operating temperature rise of 80°C. A motor performance chart shall be provided upon request exhibiting curves for motor torque, current, power factor, input/output kW and efficiency. The chart shall also include data on motor starting and no-load characteristics.

- B. The power cable shall be sized according to the NEC and ICEA standards and shall be of sufficient length to reach the junction box without the need of any splices. The outer jacket of the cable shall be oil resistant chlorinated polyethylene rubber. The motor and cable shall be capable of continuous submergence underwater without loss of watertight integrity to a depth of 65 feet or greater.
- C. Motor horsepower shall be sufficient so that the pump is non-overloading throughout its entire performance curve, from shut-off to run-out. The motor and cable shall be capable of continuous submergence underwater without loss of watertight integrity to a depth of 65 feet or greater.

2.05 PUMP MOTOR COOLING SYSTEM

- A. Pumps with motors of 12-hp and greater:
Motors shall be equipped with an integral motor cooling jacket of the closed-loop type.

2.06 CABLE ENTRY SEAL

The cable entry seal design shall preclude specific torque requirements to insure a watertight and submersible seal. The cable entry shall consist of dual cylindrical elastomer grommets, flanked by washers, all having a close tolerance fit against the cable outside diameter and the entry inside diameter. The grommets shall be compressed by the cable entry unit, thus providing a strain relief function. The assembly shall provide ease of changing the cable when necessary using the same entry seal. The cable entry junction chamber and motor shall be sealed from each other, which shall isolate the stator housing from foreign material gaining access through the pump top. Epoxies, silicones, or other secondary sealing systems shall not be considered equal.

2.07 PUMP BEARINGS

The integral pump/motor shaft shall rotate on two bearings. The motor bearings shall be sealed and permanently grease lubricated with high temperature grease. The upper motor bearing shall be a two row angular contact ball bearing to handle radial loads. The lower bearing shall be a two row angular contact ball bearing to handle the thrust and radial forces. The minimum L10 bearing life shall be 50,000 hours at any usable portion of the pump.

2.08 MECHANICAL SEAL

- A. Each pump shall be provided with a positively driven dual, tandem mechanical shaft seal system consisting of two seal sets, each having an independent spring. The lower primary seal, located between the pump and seal chamber, shall contain one stationary and one positively driven rotating corrosion and abrasion resistant tungsten-carbide ring. The upper secondary seal, located between the seal chamber and the seal inspection chamber shall be a leakage-free seal. The upper seal shall contain one stationary and one positively driven rotating corrosion and abrasion resistant tungsten-carbide seal ring. The rotating seal ring shall have small back-swept grooves laser inscribed upon its face to act as a pump as it rotates, returning any fluid that should enter the dry motor chamber back into the lubricant chamber. All seal rings shall be individual solid sintered rings. Each seal interface shall be held in place by its own spring system. The seals shall not depend upon direction of rotation for sealing. Mounting of the lower seal on the impeller hub is not acceptable. Shaft seals without positively driven rotating members or conventional double mechanical seals containing either a common single or double spring acting between the upper and lower seal faces are not acceptable. The seal springs shall be isolated from the pumped media to prevent materials from packing around them, limiting their performance.
- B. Each pump shall be provided with a lubricant chamber for the shaft sealing system. The lubricant chamber shall be designed to prevent overfilling and shall provide capacity for lubricant expansion. The seal lubricant chamber shall have one drain and one inspection plug that are accessible from the exterior of the motor unit. The seal system shall not rely upon the pumped media for lubrication.
- C. The area about the exterior of the lower mechanical seal in the cast iron housing shall have cast in an integral concentric spiral groove. This groove shall protect the seals by causing abrasive particulate entering the seal cavity to be forced out away from the seal due to centrifugal action.
- D. A separate seal leakage chamber shall be provided so that any leakage that may occur past the upper, secondary mechanical seal will be captured prior to entry into the motor stator housing.

Such seal leakage shall not contaminate the motor lower bearing. The leakage chamber shall be equipped with a float type switch that will signal if the chamber should reach 50% capacity.

E. Seal lubricant shall be non-hazardous.

2.09 PUMP SHAFT

Pump and motor shaft shall be the same unit. The pump shaft is an extension of the motor shaft. Couplings shall not be acceptable. The shaft shall be stainless steel – ASTM A479 S43100-T.

The use of stainless steel sleeves will not be considered equal to stainless steel shafts as shaft sleeves only protect the shaft around the lower mechanical seal.

2.010 PUMP IMPELLER / VOLUTE FOR N – TYPE PUMPS

A. The impeller shall be of Hard-Iron™ (ASTM A-532 (Alloy III A) 25% chrome cast iron), dynamically balanced, semi-open, multi-vane, back swept, screw-shaped, non-clog design. The impeller leading edges shall be mechanically self-cleaned automatically upon each rotation as they pass across a spiral groove located on the volute suction. The leading edges of the impeller shall be hardened to Rc 60 and shall be capable of handling solids, fibrous materials, heavy sludge and other matter normally found in wastewater. The screw shape of the impeller inlet shall provide an inducing effect for the handling of up to 5% sludge and rag-laden wastewater. The impeller to volute clearance shall be readily adjustable by the means of a single trim screw. The impeller shall be locked to the shaft, held by an impeller bolt and shall be coated with alkyd resin primer.

B. VOLUTE / SUCTION COVER

The pump volute shall be a single piece grey cast iron, ASTM A-48, Class 35B, non-concentric design with smooth passages of sufficient size to pass any solids that may enter the impeller. Minimum inlet and discharge size shall be as specified. The volute shall have a replaceable suction cover insert ring in which are cast spiral-shaped, sharp-edged groove(s). The spiral groove(s) shall provide trash release pathways and sharp edge(s) across which each impeller vane leading edge shall cross during rotation so to remain unobstructed. The insert ring shall be cast of Hard-Iron™ (ASTM A-532 (Alloy III A) 25% chrome cast iron) and provide effective sealing between the multi-vane semi-open impeller and the volute housing.

2.011 SUMP MIXING VALVE

A. One pump unit in each TOP pump station shall be equipped with an automatically operating Flygt Mix-flush Valve mounted directly to a machined boss located on the exterior of the pump volute casting that will provide mixing action within the sump at the start of the pumping cycle. The valve shall redirect a portion of the pumped media into the sump to re-suspend solids and grease by the turbulent action of its discharge.

B. The valve shall be equipped with an adjustable, wear-resistant discharge nozzle that can be used to direct flow within the sump. The valve shall operate by differential pressure across the valve and shall not require any electric or pneumatic power source to operate. The valve shall be suitable for use in Class I, Division 1 hazardous locations.

- C. The valve shall open at the beginning of each pumping cycle and shall automatically close during the pump operation after a pre-set time. A method of adjusting the valve operating time shall be provided.

2.012 MOTOR PROTECTION

- A. Each pump motor stator shall incorporate three thermal switches, one per stator phase winding and be connected in series, to monitor the temperature of the motor. Should the thermal switches open, the motor shall stop and activate an alarm. A float switch shall be installed in the seal leakage chamber and will activate if leakage into the chamber reaches 50% chamber capacity, signaling the need to schedule an inspection.
- B. The thermal switches and FLS shall be connected to a Mini CAS (Control and Status) monitoring unit. The Mini CAS monitoring unit shall be designed to be mounted in any control panel.
- C. MODIFICATION
Provide explosion-proof pumps.

2.013 ELECTRIC CONTROLS

A. ENCLOSURE AND LEVEL CONTROL

- a. The Flygt TOP pre-engineered fiberglass pump station shall be furnished with pre-installed conduit fittings for connection of the pump power/control and level control wiring. Pump station liquid level control shall be as per options listed below. A stainless steel mounting bracket and two 2" electrical conduit fitting shall be included. All electrical and control accessories shall be shipped inside of the pump station for field installation.
- b. Coordinate pump controls, electrical, and SCADA requirements with the OWNERS electrical and SCADA contractors.
- c. Provide a Flowline EchoSafe XP88 ultrasonic level sensor for pump control with float back up. Mount sensor on a 4 inch diameter riser and companion flange with a 2 inch NPT threaded connection for the level sensor. Do not exceed 8 inch riser height. Mount out of turbulence from inlet pipe. See Additional Features below.

B. PUMP CONTROL

The package pump station shall be furnished with an automatic pump control system housed in a stainless steel enclosure. The control system shall include the following features:

- a. Enclosure: Stainless Steel with aluminum inner door and padlock hasp
- b. Duplex pump station controller, including 24vdc power supply. Provide an adjustable START time delay for the lag pump.
- c. Pump thermal/seal fail protection (i.e. MiniCAS120 relays)
- d. Circuit breakers (Pump and Control Power)

- e. Across the line motor starters
- f. Control power transformer
- g. Phase Monitor for protection against over/under voltage and phase imbalance
- h. Hand-Off-Auto switches for each pump
- i. Current transformers, 1 per pump
- j. Mechanical Elapsed time meters
- k. Lightning arrestor
- l. Red-dome style flashing alarm light
- m. Alarm Horn or Bell with Alarm silence button
- n. Additional features
 - 1.) Intrinsically safe barrier for UL 913 requirements
 - 2.) Anti-condensation heater and thermostat
 - 3.) Telemetry communications: Coordinate with the OWNERS electrical and SCADA contractors. The SCADA system is based on Modicon PLCs and Modbus TCP protocol.
 - 4.) Back panel space reserved for customer-installed telemetry equipment
 - 5.) Generator and automatic transfer switch to be provided by others.
 - 6.) Duplex GFI receptacle
 - 7.) Three Float switches for backup level control (used with analog level sensor system): Install two float switches above the lag ON contacts to operate the LEAD and LAG pumps and install the third float switch below the OFF analog control level.

PART 3 EXECUTION

3.01 GENERAL

- A. At all times when the work of installing the lift station is not in progress, including worker break times, ends of the pipe shall be closed with vermin-proof and child-proof caps or plugs. Do not permit trench water to enter the pipe. Do not place tools, clothing, or other materials in the pipe. The Contractor shall maintain the interior of the lift station in a sanitary condition free from foreign materials.

3.02 EXCAVATING, BACKFILLING AND COMPACTING

Excavating, trenching, backfilling and compacting shall be performed in accordance with Section 02200.

3.03 LIFT STATION STRUCTURE INSTALLATION

Install lift station wet well, pump equipment, and controls in accordance with manufacturers' recommendations.

3.04 PIPING AND VALVES

The Flygt TOP pre-engineered fiberglass pump station shall be furnished complete with discharge pipes and fittings. Discharge piping shall be of Ductile Iron or PVC.

3.05 STANDARD PUMP FACTORY TEST

A. Each completed and assembled pump/motor unit shall undergo the following factory tests at the manufacturer's plant prior to shipment:

1. Minimum 3-point hydraulic performance test
2. No-Leak seal integrity test
3. Electrical integrity test

3.06 FIELD START-UP TEST

A. After installation, a pump station start-up shall be performed by the installing contractor under the supervision of the manufacturer's authorized representative. One day of field service shall be provided by an authorized, factory trained representative of the pump manufacturer. Services shall include, but not be limited to, inspection of the completed pump station installation to ensure that it has been performed in accordance with the manufacturer's instructions and recommendations, supervision of all field-testing and activation of the Pump Manufacturer's Warranty. The test shall demonstrate to the satisfaction of the Owner that the equipment meets all specified performance criteria, is properly installed and anchored, and operates smoothly without exceeding the full load amperage rating of the motor. The Contractor shall be responsible for coordinating the required field services with the Pump Manufacturer.

END OF SECTION

SECTION 11341

BIOFILTER VAPOR PHASE ODOR CONTROL SYSTEM

PART 1 - DESCRIPTION

1.01 GENERAL

- A. This specification includes the Biofilter equipment and installation including all associated piping, materials and construction. Connect the vapor intake to the lift station vent connection. Coordinate construction for the electrical power supply connection, provided by others.
- B. Related Work Specified Elsewhere
 - 1. Submersible Sewage Pumps and Wet Well.....Section 11311

1.02 QUALITY ASSURANCE

Provide a biofilter odor control system equal to the Bioteg stand-alone biofilter SRBF-60.

1.03 PERFORMANCE CRITERIA:

The system shall be capable of removing foul air at a rate no lower than the rate shown below and achieve the performance with the following minimum criteria.

- A. Biofilter unit SHALL be capable of 95% to 99% removal of hydrogen sulfide (H₂S) from the sewage wet well at an air flow rate of 60 cubic feet per minute (CFM) and a 50 ppm average H₂S concentration.
- B. Media Bed Pressure Drop: < 0.4 inches water column (wc) at a 3 ft bed depth
 - 1. Expected Bed Life: 3 – 7 years, depending on the concentrations
 - 2. H₂S Removal Rates: 95 - 99% at concentrations ≤ 50ppm H₂S

C. SUBMITTALS

Submit shop drawings, installation and maintenance manuals in accordance with section 01300.

PART 2 MATERIALS

2.01 BIOFILTER

- A. Provide a Bioteg Stand-Alone Biofilter SRBF-60 designed to control H₂S, ammonia and other wastewater odors at a rate of 60 cfm or equal system.

- B. HDPE Circular Filter Container
 - 1. Filter Diameter [D]: 51''
 - 2. Filter Height [H1 + H2]: 60'' Mechanical Properties of tank material
- C. 4 inch Waste air connecting branch with flange
- D. Condensate overflow / -drain ¾'' NPT
- E. HDPE Detachable Cover with flange for fan connection

2.02 BIOFILTER MEDIA

- A. Material bpc BT-50 and BT-100:
- B. 100% organic, non-hazardous, biodegradable
- C. All surfaces in contact with contaminating media: PE, PPs, PVC, stainless steel.

2.03 FAN

Provide a Fantech FR 150 equipped as follows:

- A. Housing manufacturer of engineered thermoplastic, UL listed (E128817) for outdoor use in wet locations.
- B. Totally enclosed, 115 V, 60 Hz motor at 90 watts and rated for 100 cfm at 1 inch wc.
- C. Construct unit in an HDPE Fan Housing with flange connection to biofilter cover.

2.04 IRRIGATION AND MOISTURE CONTROL

Provide an automatic surface irrigation system with a cycle timer and removable irrigation system for SRBF-60 biofilter unit with insulated internal piping and freeze protection.

- A. Water distributor with a ½'' connection
- B. Soaker Hose
- C. Electronic Timer
- D. Solenoid Valve

2.05 CONTROL PANEL FOR FAN AND IRRIGATION SYSTEM

- A. On / Off – Switch with Control Lamp
- B. Fan Control Switch (on / off) with control light
- C. Irrigation System Timer (on / off / auto timer) with control light

- D. Thermostat for Freeze Protection
- E. Malfunction Alarm Light
- F. Open Contact for signal to Control Room
- G. Emergency Off-Switch

PART 3 EXECUTION

3.01 ON-SITE REQUIREMENTS FOR INSTALLATION

- A. Install unit on a level concrete foundation.
- B. Connections: Provide all pipe and fitting for the following.
 - 1. Waste Air Inlet Pipe 4'' flange from the wet well to the biofilter.
 - 2. Install Condensate Drain Pipe (2'')
 - 3. Provide conduit and wire for the power connection for the fan, heater, and controls. 115V, 60 hertz, single phase,
 - 4. Provide water supply for the irrigation system and connect to the ¾'' NPT fitting on the biofilter unit.

3.02 POWER AND WATER CONSUMPTION

- A. Power
 - 1. Fan: approx. 2 kWh/ day
 - 2. Heat tracing approx. 2 kWh/ day (during cold winter days < 50 F)
- B. Water: Approx. 15 gallons/ day

3.03 MAINTENANCE

The biofilter material will have to be replaced once odors start to reoccur. It is expected to last up to 7 years, depending on the contaminant concentration.

- A. Inspect moisture of filter material, weekly.
- B. Inspect connections to filter, monthly.
- C. Inspect fan, monthly.

END OF SECTION

**APPENDIX C
GEOTECHNICAL REPORT**

CONTRACTOR: DOUBLE M CONSTRUCTION

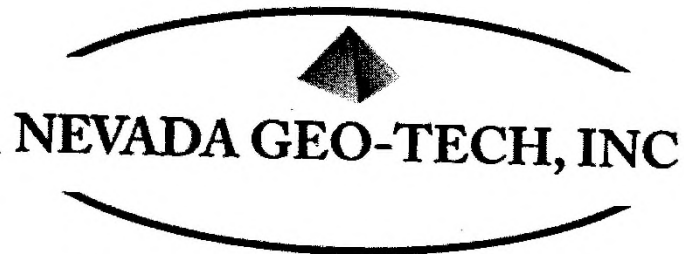

5170 East Manse Road, Pahrump, Nevada 89061
775.751.5222

GEOTECHNICAL SOILS PROPERTY REPORT

Date Prepared:
February 10, 2014

Prepared For :
Spring Mountain Raceway LLC, Owner
3601 South Nevada Highway 160
Pahrump, Nevada 89048
Double M Construction, General Contractor

Project:
Spring Mountain Estates, PUD
Spring Mountain Motorsports Ranch

Location of Site Investigation
No Addresses Assigned
Vicinity of: 3601 South Nevada Highway 160
Pahrump, Nevada 89048
Part of Nye County APN: 027-741-11
Part of Nye County APN: 027-741-12
Township Of Pahrump, State Of Nevada, 89048

Existing Pahrump Zoning: HI
Proposed Zoning, Planned Unit Development (PUD)
Approximate Net Acreage: 35 Acres
Gross Acreage: 307.42

Site Use: Mixed Use, Residential

TABLE OF CONTENTS

PAGE	SECTION
1.	COVER PAGE
2.	TABLE OF CONTENTS
3	TABLE OF CONTENTS (CON'T)
4	1.0 PROJECT IDENTIFICATION AND LOCATION
4.	1.1 GENERAL AND PROJECT DESCRIPTION
4	1.2 PURPOSE AND SCOPE
4	1.3 STAFF ENGINEER RESPONSIBLE CHARGE OF WORK. NRS 625.610
5	1.4 GEOTECHNICAL REPORT LIMITATION
5	1.5 GEOLOGIC SETTING
5	2.0 GENERAL SITE CONDITIONS
5.	2.1 GENERAL SITE INVESTIGATION AND SITE RECONNAISSANCE
5.	2.2 GENERAL FIELD INVESTIGATION AND NATIVE ELEVATION
5	2.3 SURFACE CONDITIONS
6	2.4 SUBSURFACE CONDITIONS
6	2.5 CONSTRUCTION ELEVATION FIRM DETERMINATION
6	3.0 INTERNATIONAL BUILDING CODE
	<small>Required discussions by NCC 15.16.075, 2006-15</small>
6	3.1 FLOOD HAZARD ZONE
6	3.2 SITE CLASS,
6	3.3. SOIL LATERAL LOAD
6	3.4 PRESUMPTIVE LOAD BEARING VALUES
6	3.5 TECTONIC FAULTING AND REGIONAL SEISMICITY
7	3.6 WIND LOADS
7	3.7 SNOW LOADS
7	4.0 FINDINGS
7	4.1 ADVERSE CONDITIONS
7	4.2 CLAY SWELL AND SWELL SENSITIVITY
7	4.3 CONSOLIDATION OR HYDRO-COLLAPSIBLE SOIL
7	4.4 CHEMICAL HEAVE
7	4.5 UNCONTROLLED FILLS OR DUMPING ON-SITE
8	4.6 HIGH GROUND WATER TABLE
8	4.7 TRENCHING LESS THAN 3' DEPTH
8	4.8 DRAINAGE
8	4.9 RAINWATER, LANDSCAPING AND EROSION PROTECTION
9	5.0 EARTHWORK CONSTRUCTION, EXCAVATION, GRADING AND FILL
9	5.1 SITE GRADING
9	5.2 ELEVATIONS OF FINAL FINISHED GRADE OF EARTHWORK
9	5.3 Not Used
9	5.4 BACKFILL MATERIAL PLACEMENT

PRELIMINARY GEOTECHNICAL SOILS PROPERTIES REPORT,
CONTROLLED PAD CONSTRUCTION

TABLE OF CONTENTS (CON'T)

PAGE	SECTION
9	5.5 SLOPE
9	5.6 PAVEMENT AND PARKING AREAS
9	5.7 COMPACTION AND REPORTING
10	5.8 IMPORTED STRUCTURAL FILL AND AGGREGATE BASE
11	6.0 ONE STORY, WOOD FRAME CONSTRUCTION CONTROLLED PAD DEVELOPMENT
11	6.1 CONTROLLED PAD EARTHWORK
11	6.1.a. CONSTRUCTION DIAGRAM ONE STORY CONTROLLED PAD OVER-EXCAVATION
12	6.2 ONE STORY, WOOD FRAME CONSTRUCTION FOUNDATION, FOOTINGS AND SLAB ON GRADE
12	6.3 PATIO COVERS
12	6.4 FORMWORK FLATWORK SIDEWALKS
13	7.0 TWO STORY, WOOD FRAME CONSTRUCTION CONTROLLED PAD DEVELOPMENT
13	7.1 CONTROLLED PAD EARTHWORK
13	7.1.a. CONSTRUCTION DIAGRAM ONE STORY CONTROLLED PAD OVER-EXCAVATION
14	7.2 TWO STORY, WOOD FRAME CONSTRUCTION FOUNDATION, FOOTINGS AND SLAB ON GRADE
14	7.3 PATIO COVERS
14	7.4 FORMWORK FLATWORK SIDEWALKS
15	8.0 DYNAMIC SETTLEMENT
15	9.0 FOUNDATION SETTLEMENT
16	10.0 LIMITATIONS
16	11.0 REFERENCES
APPENDIX A:	LABORATORY TESTS
APPENDIX B:	CONTRACTOR DOCUMENTS VICINITY MAP
APPENDIX C:	NYE COUNTY, PAHRUMP REGIONAL PLANNING DOCUMENTS, NOTICES AND MAPS
APPENDIX D:	PLATES 1-5

1.0 GEOTECHNICAL SOILS PROPERTIES REPORT

1.0 GEOTECHNICAL SOILS PROPERTIES REPORT

Spring Mountain Estates, No Address Assigned
Part of Nye County APN: 027-741-11 / 027-741-12
Pahrump, Nevada 89048

Nevada Geo-Tech Inc., Project No. 14-005
February 10, 2014

Attention: Spring Mountain Raceway, LLC.
Project: Spring Mountain Estates, Residential (PUD), 77 Lots and Common Areas
Subject: Geotechnical Soils Properties Report
Site Use: Residential
Nye County APN No: 027-741-11 / 027-741-12, Existing Nye County Zoning: HI
Development: Spring Mountain Estates
Reference: Tentative Map, Spring Mountain Estates, Impulse Engineering, Sheet 1 and 2, 11/05/2013

1.1 GENERAL AND PROJECT DESCRIPTION

This report presents the results of an in-situ soils and geologic exploration for a residential Planned Unit Development, located in the vicinity of Spring Mountain Raceway, Township of Pahrump, Nye County, Nevada. Estimated net acreage for construction: +/- 35 acres. Total number of residential lots: 77, variable square footage per lot.

Site construction is purported to consist of Residential dwellings, two stories or less, wood frame construction. Public utilities are not installed. Utility Plans, design and installation specification are submitted by others and pending approval of the Subdivision Plan.

Roadway design and installation are part of the pending subdivision Plan. Graveled Private Street sections are installed on the project perimeter and interior.

The site construction acreage is vacant. Mechanical site roadway disturbance is apparent. The site is roughly level and ± 0.0 inches level with proposed street crown elevation. The Flood Hazard Zone designation is 'X'. See FEMA Community Panel Numbers 3200184420C and 3200184435C, dated September 28, 1990 with LOMR revision. Storm-water diversion plans design and specifications are submitted by others and are purported to provide adequate channel and berm diversion across the north property line of the Project. s.

1.2 PURPOSE AND SCOPE

The purpose of this geo-technical report is to determine the surface and subsurface conditions as related to the geo-technical engineering properties of the site soils and to provide general geo-technical design criteria and construction recommendations for the proposed site development. The scope of this investigation includes six subsurface investigations at selected sites and the collection of representative soils samples for laboratory testing.

Scope of Work: Geotechnical Field Testing Locations.

TP-1	Lots 1-9	(1) Laboratory Suite	Vicinity CE2
TP-2	Lots 10-27 and CE3	(1) Laboratory Suite	Vicinity CE3
TP-3	Lots 28-37 and CE5	(1) Laboratory Suite	Vicinity Lot 32
TP-4	Lots 46-77	(1) Laboratory Suite	Vicinity Lot 61
TP-5	Lots 38-46	(1) Laboratory Suite	Vicinity Lot 42
TP-6	Future Parcel Lot 1,2,3	(1) Laboratory Suite	Vicinity Parcel 1 >> 2

Respectfully Submitted,

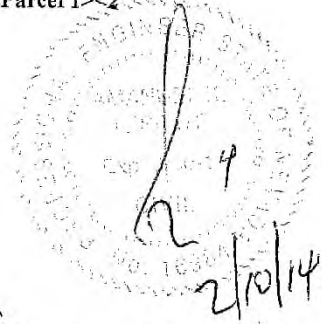

L3 Staff Engineer Responsible Charge of Work Amanuel Tesfaye, P.E.
State Of Nevada License #16984, Expires 6/30/14

NEVADA GEO-TECH, INC.

5170 EAST MANSE ROAD, PAHRUMP, NEVADA 89061

PROJECT No. 14-005

1.4 GEOTECHNICAL REPORT LIMITATION: A geotechnical report is based on conditions that existed at the time the study was performed. Site exploration identifies subsurface conditions only at those points where subsurface tests are conducted or samples taken. No warranties, expressed or implied, oral or written, are intended or made. We prepared this report as an aid in design of the proposed project site use and development. Any contractor reviewing this report must draw his own conclusions regarding site conditions and minimum specific construction techniques to be used on this project.

1.5 GEOLOGIC SETTING

Extreme southern Nye County is located along the southwestern boundary of Nevada and is underlain by a large variety of rock, ranging in age from Precambrian to Quaternary. The Geologic Map of Southern Nye County, by Henry Cornwall (1967) classifies the soil in the Pahrump Valley as Qal. Broadly defined alluvium soil comprises fan and stream gravels, flanking mountains and hills, grading outwards into sands and silts in the valley bottom.

The Pahrump Valley Fault Zone (PVFZ) lies within Pahrump Valley, between the Spring Mountains of Nevada and the Kingston and Nopah Ranges of California, and follows the California-Nevada state line. This project is located in an area of active and potentially active tectonic faults, north-west-trending right -lateral shear known as the Walker Lane Belt (Stewart, 1988). The southern extension of the PVFZ is active and represents a potential seismic hazard for Pahrump, and the full length of the PVFZ could be capable of 7+ event, (Shields et al., 1996).

The area of site investigation, is located within the Open File 99-14, the Pahrump Quadrangle.

Soils are identified as Qay₁, Alluvial Fan

An identifiable North-South trending fault line is 3,500 ft North-East of the site. The risk for surface rupture is inferred to be low. A seismic investigation is not required (Reference: International Building Code 2006, Section 1802 2.4) However, the seismic risk in terms of recurrence and maximum potential magnitude is not yet well established. Therefore, the potential for surface rupture at magnitudes higher than 6.0 cannot be precluded. No known faults or fissures on published maps are shown to cross the site.

The site located within Regional 1, Site Class D,

2.0 GENERAL SITE CONDITIONS

2.1 GENERAL SITE INVESTIGATION

A site investigation was authorized by General Contractor, and completed 2-3-2014, which consisted of observation, documentation, and sampling of surface and subsurface conditions of a proposed controlled pad construction for single and two story construction site development. It is our understanding that the site development would consist of performing typical cut and fill earthwork, to attain the desired graded configuration, consistent with a residential wood frame structure and associated improvements. Dead and live foundation loading conditions are expected to be typical considering the wood frame construction anticipated

2.2 GENERAL FIELD INVESTIGATION AND NATIVE ELEVATION

At the time of the site investigation we found the site developed, clear of debris and onsite vegetation is typical and indigenous to southern Nevada. The lots are roughly level with no pronounced highs or lows and no indication of surface water ponding. No springs, seeps, fissures or subsidence was observed at the site. No hydrostatic condition exists.

Reference: NCC 2006-15, 15.16.075, (g), Effective 8-7-06

2.3 SURFACE CONDITIONS

The site topography generally directs surface drainage into small south-southwest flowing ephemeral (i.e., seasonal) drainages. A stormwater drainage R.O.W. crosses north to south across lot 47 property line. Surface water was not observed on-site during the evaluation. Adjacent Assessor Parcels westerly are occupied by facilities of the Spring Mountain Raceway Complex. Historical use of the proposed pad sites is not evident.

2.4 SUBSURFACE CONDITIONS

Sampling method is identified on exploration log. Additional explorations are not required. Bulk samples were collected, (ASTM D 420, 10). The geologic soil classification of the site development will be determined by ASTM laboratory analysis.

2.5 CONSTRUCTION ELEVATION

The owner/builder or grading contractor completing the pad construction earthwork must verify final pad grade elevation for compliance with minimum elevations required by the Base Flood Zone X designation. The General Contractor should comply with applicable IBC 2006, Sections 109.3.3, 1612.2, 1612.5 and International Commercial Code Section 109.1.3 and the Federal Insurance Rate Map. for final building finish floor elevation. Drainage should be controlled and directed away from the controlled pad at a minimum slope of 5% for a minimum water infiltration barrier of 5 feet.

3.0. INTERNATIONAL BUILDING CODE 2006

Note: Following disclosures are required by NCC 15.16.075

3.1 FLOOD HAZARD ZONE: WHEELER SOUTH WATERSHED (BFE 'X')

Reference: FEMA Community Panel Numbers 3200184420C and 3200184435C, dated September 28, 1990 with LOMR revision

CONCLUSION Base flood elevation: Zone X, No Base Flood Elevation Established.
Recommended Top Finished Floor: 12" above highest adjacent grade.

3.2 SITE SOIL DEFINITION,

Site Class C: Very Dense Soil Profile
(GM), Gravel sand-silt mixture
Shear $ft/s < v\check{\le}1200<\check{v}, \leq 2500$

3.3 SOIL LATERAL LOAD

UNIFIED SOIL CLASSIFICATION DESIGN SOIL LATERAL LOAD

ACTIVE PRESSURE: 40 lb/ft³

AT REST PRESSURE: 60 lb/ft³

3.4 PRESUMPTIVE LOAD BEARING VALUES

ALLOWABLE FOUNDATION AND LATERAL PRESSURE

(GM, SP, SC) 2,000 psf., Lateral Bearing 150, Coefficient of friction 0.25

For S¹; 1 pound per ft² = 0.0479 kPa. 1 pound per ft² per foot = 0.157 kPa/m S¹

3.5 REGIONAL SEISMICITY,

Reference: IBC 2006, 1801.2.1, Foundation Design for seismic overturning

Reference: IBC 2006, TABLE 1613.5.2 SITE CLASS DEFINITION

SITE SOIL PROFILE

CLASS NAME

D Stiff soil profile

S_μ 1,000 to 2,000 psf

Based on this general location, a search of the Seismic Design Parameters, Version 3.10. USGS Open File Report 01-437 on September 28, 2005 the following special accelerations for 0.2 seconds (SA) and 1.0 second (SA) period for 2% probability of exceedance (PE) in 50 years for a Site Class of D;

<u>PERIOD</u>	<u>ACCELERATION</u>
0.2 sec., S _s	0.513g
1.0 sec., S _t	0.184g

For the purpose of seismic design, the Site Class was determined using Section 1615.1.1, Site Class Definitions of the 2006 International Building Code(IBC). Based on our knowledge of the site, the Site Class is D.

Adjusting the Site Class d , S_s and S_1 values for Site Class D, the five-percent spectral response acceleration at short periods, S_{ps} , is 0.48g and at 1-second period, S_{p1} , is 0.25g.
 $2/3 \times F_a \times S_s = 40.8\%$

3.6 WIND LOADS; SPECIAL WIND REGION 90; f 10psf (0.479 kN/m²) (area f^2) (area of building vertical plane)
 Category 1 factor: I_w 0.8

3.7 SNOW LOADS: 2500 FT ELEVATION = 10 P_g ,
 Category 1 factor: I_s 0.8

4.0 FINDINGS:

4.1 ADVERSE CONDITIONS: No In-situ (native soil) adverse soil conditions have been identified in the proposed structural area. No known impacts on adjoining properties are apparent. Soils subject to liquefaction were not encountered.

Laboratory samples locations are shown on the attached Appendix A; geo-technical plot plan. The soil profile of material sampled from the site is predominantly classified as a (GM) Gravel sand-silt mixture deposited by alluvial sheet-flow drainage typical to this area of the Pahrump Valley. The native soil varied from dense at near surface to very dense at 10.0 ft. depth. The moisture content of the materials encountered were moist to the maximum depth explored, 10.0' bgs. Ground water was not encountered. Records kept by Nye County, indicate that groundwater levels near the site are 106 feet or more, in depth.

4.2 Clay swell and swell sensitivity:

Expansion Index Test: ASTM D 4829, CALIFORNIA UBC 29-2.
 Standard 60 PSF Swell Test

In Southern Nevada a variation of the HUD swell test is used. The test was initially known as the North Las Vegas Expansion Test The swell test sample is a disturbed sample.

Thickness: 1 inch laterally confined by retaining ring. ASTM 2435

Oven Dry: 60°C, eight hours

Use: 60 pound psf surcharge load. (2.9kPa)

Interpretation: NC 15.16.077.1

SNA, Table 1805.8 Percent of Swell <4, Plastic Index < 10 Then:

Expansion Potential versus Percent Swell and Minimum Foundation Design Criteria

Expansion potential	Percent swell under 60 psf surcharge	Minimum thickened edge, ftg depth (in.)
Low	0-4	12
Moderate	4-8	12
High	8-12	18
Critical	12-16	24
Test Swell	= (Final Thickness - Initial Thickness) x 100	
Substitute	= 0.9990 - 0.9988 x 100	
EP	= NA	

The material encountered is not expansive in the presence of water.

4.3 Consolidation or hydro-collapsible soil:

Water must not be allowed to pond or seep into the earthwork.

4.4 Chemical heave, corrosion and solubility;

On-site soils have a corrosive potential to concrete and metal. The construction materials selected should be resistant to corrosion.

4.5 UNCONTROLLED FILLS OR REFUSE DUMPING ON-SITE;

Note: Uncontrolled fill materials are not considered competent for use.

4.6 HIGH GROUND WATER TABLE;

Ground water is not expected to effect the project site development. These observations reflect conditions at time of this investigation and do not preclude changes in local ground water conditions from natural causes. Groundwater was not encountered in explorations.

4.7 TRENCHING (Less than 3.0' depth):

Structural Pad Excavating; Foundation footing, utility plumbing trenches should be moistened to optimum moisture content and compacted to 95 percent of field density proctor. Spoils should be removed from the structural pad site and stockpiled for other use..

Utility Trenching; Utility trenches should be moistened to optimum moisture content and compacted to 95 percent of field density proctor. Pipe zone shading should be moistened and compacted. Backfill with imported, select pit run material, may reduce the risk of sub-surface water infiltration into the structural pad.

Most soils within the Pahrum dry lake bed vicinity will vector moisture into a replacement structural pad if not properly compacted with moisture.

Native soils are not anticipated to be suitable for use as trench bedding. Bedding material should be non-plastic and shall conform to the following gradation requirements. Minimum compaction by the sand cone method is 95%.

TRENCH BEDDING

SIEVE SIZES	PERCENTAGE PASSING BY WEIGHT
3/8"	100
#4	90-100
#50	10-40
#100	3-20
#200	0-10

4.8 DRAINAGE:

The Wheeler Wash South watershed is an Alluvial Fan deposition. Drainage is sheet-flow which follows existing contours and small ephemeral washes toward the Southwest. Residential Lot drainage reports storm-water toward the street-side swell and swale. Positive drainage toward the street side drainage shall be maintained, controlled and directed away from the building pad.

Performance of the foundation system recommended in this report is dependent on the ability to keep moisture from penetrating the native soils below foundations. Irrigation should be kept to a minimum. s.

4.9 RAINWATER, LANDSCAPING AND EROSION PROTECTION:

Where water impacts the ground from the edge of the roof, a downspout, scupper, valley or other rainwater collection or diversion device should used to prevent soil erosion and direct the water away from the foundation. Water must be directed away from the construction pad a minimum of 15 feet. Landscape irrigation pipe and manifolds should be installed 15 feet minimum from the structural earthwork pad, and maintain positive drainage away from the earthwork. Water must not be allowed to pond or seep into the earthwork. Use of landscape borders which inhibit the positive flow of water away from the pad is not recommended.

5.0 EARTHWORK CONSTRUCTION, EXCAVATION, GRADING AND FILL

5.1 SITE GRADING;

Slopes and grade variations may require additional fill material. The level, top final grade elevation of controlled pad elevations, and compliance with flood zone and storm water drainage plans and design are required.

The native, over-excavated material is **acceptable** for use as structural backfill material.

Native material should be removed, and stockpiled for conditioning and used as backfill material. Proctored Type II, Class B material is recommended for use as controlled pad, top finished grade, cap material. Grading Plans and Design are by others.

5.2 ELEVATION:

The General Contractor should comply with applicable International Building Code Sections 109.3.3, 1612.2, 1612.5 and International Commercial Code Section 109.1.3 and the Federal Insurance Rate Map requiring an Finished Floor Elevation Certificate. Drainage should be controlled and directed away from the controlled pad at a minimum slope of 5.0% for a minimum water infiltration barrier of 5 feet, over plan in plan view. We recommend the top of pad elevation above the highest adjacent elevation be in addition to typical slab on grade thickness to determine the Finished Floor Elevation.

5.3 Not Used

5.4 BACKFILL MATERIAL PLACEMENT;

The bottom of over excavation shall be scarified 12 inches minimum and moisten to optimum moisture and compacted to a dense state of +95% compaction relative maximum dry density. Flooding or jetting for backfill compaction shall not be used.

It is important that the bottom of cut native soils be scarified, moistened to Optimum and compacted to above 95 % maximum dry field density (ASTM D1557). This layer will act as a relatively impermeable fill blanket and help keep moisture from reaching any porous materials. If porous soils below the compacted fill blanket experience an increase in moisture, additional settlement may occur.

Reference; 2006 IBC 1805.8.3

Native Material Expansion <>Shrinkage: (GM) Gravel sand-silt mixture < 2 %

5.5 SLOPE

Site Development lot: Inclinator 205° W, 2-3.°d. (Slight Slope)

Grade or slope design and topographic grading plans are not within the scope of this report.

5.6 PAVEMENT AND PARKING AREAS:

Reference: Tentative Map, Spring Mountain Estates, Impulse Engineering, Sheet 1 and 2, 11/05/2013 Private Street Section, and CUL-DE-SAC designs are presented for the Private Roadway.

5.7 COMPACTION AND REPORTING

Each lift of structural fill sub base and base select material should be placed in ± 6 inch horizontal plane lifts, compacted, while maintaining the optimum moisture and built to rough-final grade. Native run material should not contain particles greater than 6 inches in diameter. Type II Aggregate fill used as structural fill should be laboratory tested for compliance with this report.

(Near-surface): The bottom of excavation, (native soil), should be scarified 12 inches, and moistened to at least optimum or above moisture content, and compacted to a minimum relative compaction of 95% of the laboratory standard proctor (ASTM D 1557), (IBC 2006, Section 1803.5). Soils should not be allowed to dry out or crack. Any dried or cracked soils shall be wetted until they reach acceptable moisture content or they could be excavated and replaced with acceptable, properly compacted fill. Foundation soils should not become saturated during or after construction. Infiltration of water into foundation or utility excavations should be prevented during construction. Utility lines should be properly installed and the backfill properly compacted to avoid possible sources for subsurface saturation.

ASTM Testing:	
COMPACTION TESTING	ASTM D 1556
MOISTURE TEST	ASTM D 2216
PROCTOR REPORT AND SUMMARY	ASTM D 1557
SIEVE ANALYSIS TEST DATA, SITE FILL MATERIAL	ASTM D 422

Import replacement structural backfill:

PARTICLE SIZE DISTRIBUTION MECHANICAL	
SIEVE SIZES	PERCENTAGE PASSING BY WEIGHT
6"	100
¾"	70-100
#40	15-70
#200	5-25

Structural fill shall consist of all fill subjected to structural loading. This material shall consist of suitable non-expansive soils having a liquid limit less than 20 and a plasticity index less than 10.

TYPICAL EARTH WORK COMPACTION TEST AND DOCUMENTATION INTERVAL;
BOTTOM OF OVER-EXCAVATION; Field Density Compaction Test, Field Moisture Test,
EACH LIFT; Field Density Compaction Test, Field Moisture Test,

Lateral Earth pressures; Lateral loads may be resisted by soil friction and by the passive resistance of the soil. A coefficient of friction of 0.35 may be used between foundations or floor slabs and the supporting soils. The passive resistance of the natural soils or properly compacted fill may be assumed to be equal to the pressure developed by a fluid with a density of 250 pounds per cubic foot and the frictional resistance of the soils may be combined without reduction in determining the total lateral resistance.

NOTE: Upon completion of the grading earthwork the Staff Professional Engineer shall certify the work completed is in accordance with the Geo-technical Recommendations.

**5.8 IMPORTED STRUCTURAL FILL AND AGGREGATE BASE
SELECT MATERIAL:**

BEARING WEIGHT OF IMPORT FILL (Modifying native bearing materials): We recommend that the structure be set upon a pad with allowable net bearing pressure, of 2000 psf., or as designed by the structural engineer. An increase of 20% of the allowable bearing pressure is allowed for each additional foot (0.3 m) of depth;

(GW and GP),	2,500 Allowable Foundation Pressure (psf)
Bearing Pressure: 2000 psf, Lateral Bearing:	200 psf, Coefficient 0.35
(SW, SP, SM, SC, GM. and GC Material).	2,000 Allowable Foundation Pressure (psf)

Suitability of on-site soils for use as fill material; The on-site soils are suitable for use as structural backfill material when processed and compacted to maximum density.

Enclosure: Imported controlled pad cap material:

Appendix A: Wulfenstein Construction Co. Inc. Aggregate Test Report
 Mesquite Material Testing, LLC., Project # 175-1
 Maximum Density: 141.6
 Optimum Moisture: 6.4

6.0 ONE STORY, WOOD FRAME CONSTRUCTION CONTROLLED PAD DEVELOPMENT

6.1 CONTROLLED PAD EARTHWORK

Residential construction over-excavation / replacement:

Over-excavation:	2.00 ft bgs
Replacement Import Fill:	2.75 ft
Replacement Controlled Pad Cap	0.25 ft. (-3/4)graded aggregate
Over build in plan view:	5.00 ft

$Q = 2000 - q_u / 0.20 = 3.0 \text{ ft}$

Use 3.0 ft

Reference; International Building Code 2006, Section 1605.3

GW -SAND; $\phi_1 = 45^\circ$, $c_1 = 0$, $E_1 = 100 \text{ kpa (200 psf)}$, $\nu_1 = 0.2$, $\gamma_1 = 22 \text{ kN/m}^3 (134.7 \text{ pcf})$
 Unconfined Compressive Strength = NV lb/ft²
 Cohesion, C (factor³) = NV lb/ft²

CONSTRUCTION OVER-EXCAVATION / REPLACEMENT FILL:

Certification measurements from the bottom of over-excavation were used to certify earthwork and pad dimensions.

6.1.a. CONSTRUCTION DIAGRAM ONE STORY CONTROLLED PAD OVER-EXCAVATION

Not To Scale

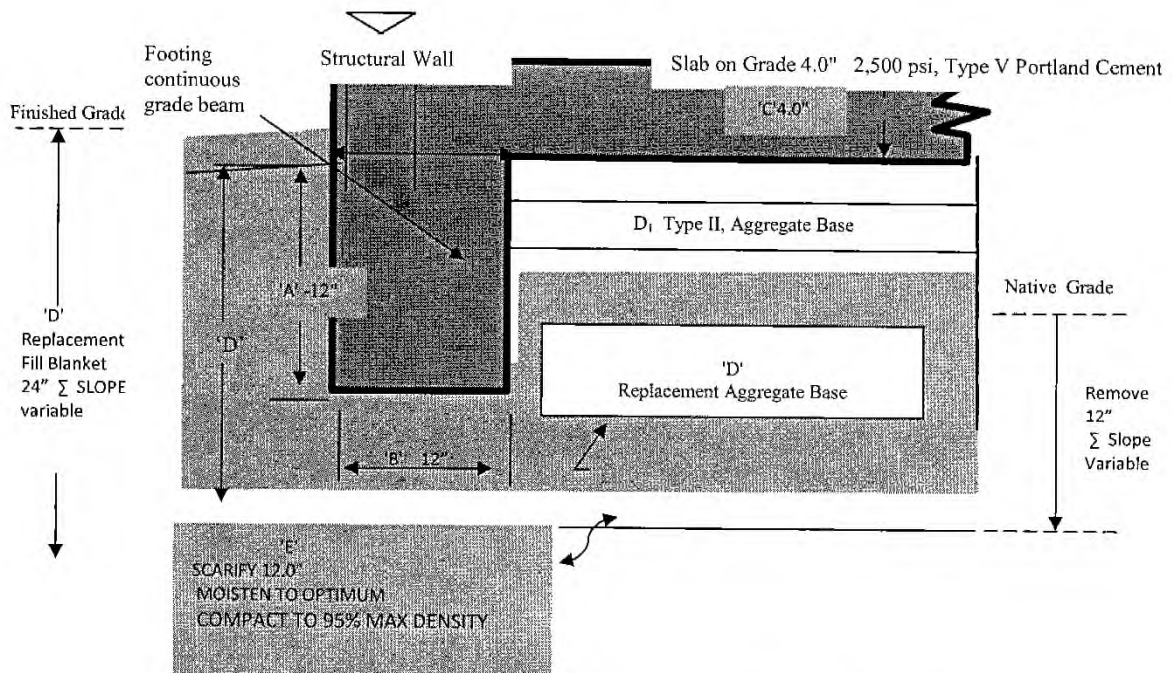

- A' - Depth of grade beam footing = 12" minimum.
- B' - Width of Foundation Footing = 12" minimum.
- C' - Thickness of Slab on Grade = 4.0" minimum.
- D' - Material Fill Blanket = 2.75' Σ slope
- D1 Type II, Aggregate Base = 0.25'
- E' - Bottom of Over-Excavation Variable 24" btf

6.2 ONE STORY, WOOD FRAME CONSTRUCTION FOUNDATION, FOOTINGS AND SLAB ON GRADE

Compliance with recommendations presented by the American Concrete Institute (ACI 318) for slabs on grade for all concrete placements and curing operations is required. Improper curing techniques and/or excessive slump (water-cement ratio) could cause excessive drying or shrinkage resulting in random cracking and/or slab curling. Use of sulfate resistant concrete, Type V, Portland Cement, or equivalent for sulfate exposure conditions, is recommended.

Conclusion: The Potential Weathering For Concrete is classified as: Severe Exposure
IBC 2006, Figure 1904.2.2 Probability Map

TABLE 1904.2.2 Minimum Specified Compressive Strength	
(f'c) @ 28 days psi: Portland Cement: Type V	2,500 psi
Maximum slump:	5 inches or less
Maximum Air Entrainment, ACI 318 Section 4.2.1	3%

Plain, un-reinforced concrete shall not be used for foundation in Seismic Zone, Class C soil.
The use of admixture in concrete must be in compliance with ACI 318 and P.C.I. Manual 128.
Placement of concrete must be at an ambient temperature of 50°F rising minimal.

Slab on Grade

Monolithic placement: Slab-on-grade; minimum of 4.0 inch thickness.
Steel Reinforcement: Use #4 rebar, grade 60, 24.0" c.c., tied both ways, no lower than mid-height, downturned and tied to footing rebar. Slice: 40x
Use of concrete blocks 2" x 2" x 2" mid-height of the rebar is required: 1:25ft²

Continuous Footing Grade Beam:

1. Dimension, 12" footing width x 12" embedment depth, continuous spread.
Reference: International Building Code 2006,
 2. Footings reinforcement with steel rebar,
 - a. Exterior, 4 #4 rebar, c.c. tied both ways, Splice: 40x
 - b. Interior, 4 #4 rebar, c.c., tied both ways, Splice: 40x
- Footing compaction effectiveness: 95% Footing Moisture: Optimum

Clear Span Point Load Column Foundation.

1. Point Load Column: 2.0' x 2.0' x 2.0' column.
Anchor Bolt, minimum 18" U.N.O., ¾" x 18.0".
Anchor Bolts shall have one washer and one hex nut minimum, Grade A307
2. Column Load Caging
Use #4 rebar grade 60 caged both ways, clear bottom 6.0", 3 mat caged 6.0" elevation.

DWELLING CONCRETE SLAB-ON-GRADE: Vapor Transmission Retarder: Uniform Concrete Curing and Salt Barrier: IBC 1910.1. In areas where dampness would be objectionable, it is recommended that the floor slab be supported on an impermeable moisture barrier. The concrete slab-on-grade should be underlain with a barrier consisting of a minimum 10 mil polyvinyl chloride or equivalent membrane, adequately lapped (6 inch joints not less than 6 inches) placed on top of the select import fill. A minimum two-inch thickness of select washed sand material should be placed over the polyvinyl material for a capillary barrier and to aid in uniform curing of the concrete.

6.3 PATIO COVERS;

A patio cover may be supported on a concrete slab on grade without footings, provided the slab is not less than 3.5 inches (89 mm) thick and further provided that the columns do not support live and dead loads in excess of 750 pounds (3.34 kn) per column.

6.4 FORMWORK, FLATWORK SIDEWALKS

Monolithic Pour: Use Portland Type V concrete minimum of 3.0 inches in thickness.
Use of concrete blocks for proper height of the rebar is required: 1:5ft²
Steel Reinforcement: Use #3 rebar, grade 60, 24.0" c.c., tied both ways.

7.0 TWO STORY, WOOD FRAME CONSTRUCTION CONTROLLED PAD DEVELOPMENT

7.1 CONTROLLED PAD EARTHWORK

Residential construction over-excavation / replacement:

Over-excavation:	2.00 ft bgs
Replacement Import Fill:	2.75 ft
Replacement Controlled Pad Cap	0.25 ft. (-3/4) graded aggregate
Over build in plan view:	5.00 ft

$Q = 2500 - q_u / 0.20 = 3.0 \text{ ft}$

Use 3.0 ft

Reference; International Building Code 2006, Section 1605.3

GW -SAND; $\phi_1 = 45^\circ$, $c_1 = 0$, $E_1 = 100 \text{ kpa (200 psf)}$, $\nu_1 = 0.2$, $\gamma_1 = 22 \text{ kN/m}^3 (134.7 \text{ pcf})$

Unconfined Compressive Strength = NV lb/ft²

hesion, C (factor³) = NV lb/ft²

CONSTRUCTION OVER-EXCAVATION / REPLACEMENT FILL:

Certification measurements from the bottom of over-excavation were used to certify earthwork and pad dimensions.

7.1.a. CONSTRUCTION DIAGRAM MULTIPLE STORY CONTROLLED PAD OVER-EXCAVATION

Not To Scale

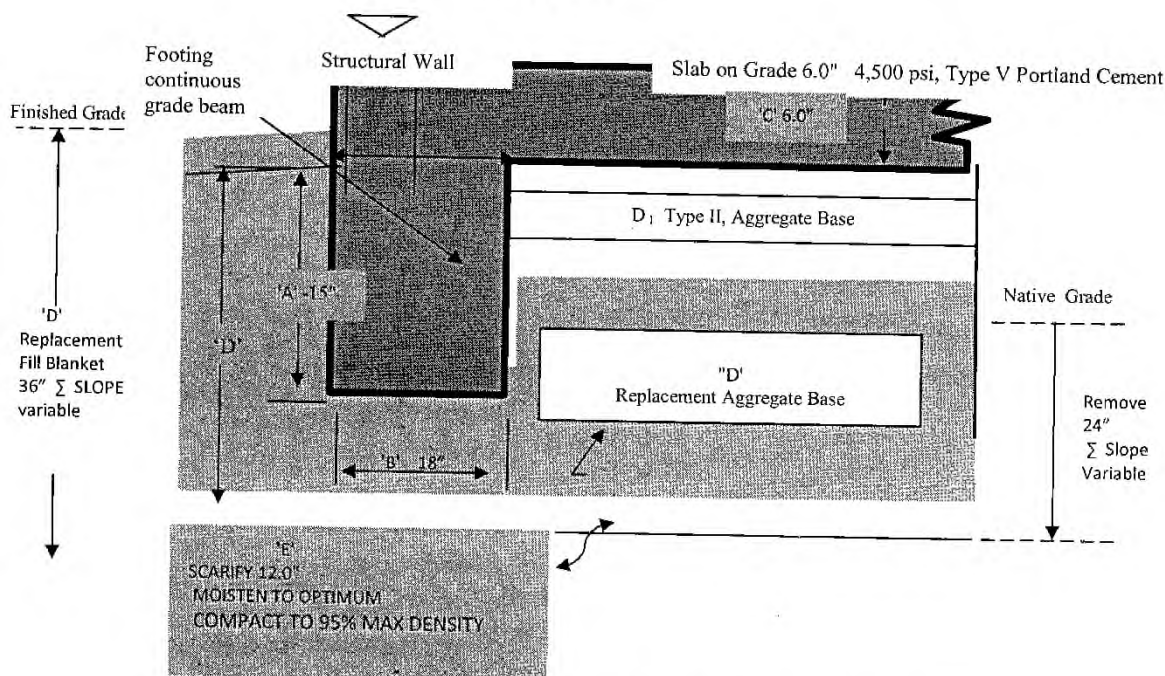

- A' - Depth of grade beam footing = 15" minimum.
- B' - Width of Foundation Footing = 18" minimum.
- C' - Thickness of Slab on Grade = 6.0" minimum.
- D' - Material Fill Blanket = 2.75 Σ slope
- D1 Type II, Aggregate Base = 0.25'
- E' - Bottom of Over-Excavation Variable 36" btfg

7.2. TWO STORY, WOOD FRAME CONSTRUCTION FOUNDATION, FOOTINGS AND SLAB ON GRADE

Compliance with recommendations presented by the American Concrete Institute (ACI 318) for slabs on grade for all concrete placements and curing operations is required. Improper curing techniques and/or excessive slump (water-cement ratio) could cause excessive drying or shrinkage resulting in random cracking and/or slab curling. Use of sulfate resistant concrete, Type V, Portland Cement, or equivalent for sulfate exposure conditions, is recommended.

Conclusion: The Potential Weathering For Concrete is classified as: Severe Exposure

TABLE 1904.2.2 Minimum Specified Compressive Strength

(f'c) @ 28 days psi: Portland Cement: Type V	4,500 psi
IBC 1805.9: Table 1904.2.2(2)	
Maximum slump:	5 inches or less
Maximum Air Entrainment, ACI 318 Section 4.2.1	3%

Plain, un-reinforced concrete shall not be used for foundation in Seismic Zone, Class C soil. The use of admixture in concrete must be in compliance with ACI 318 and P.C.I. Manual 128. Placement of concrete must be at an ambient temperature of 50°F rising minimal.

Slab on Grade

Monolithic placement: Slab-on-grade; minimum of 6.0 inch thickness.

Steel Reinforcement: Use #4 rebar, grade 60, 24.0" c.c., tied both ways, no lower than mid-height, downturned and tied to footing rebar. Slice: 40x

Use of concrete blocks 2" x 2" x 2" mid-height of the rebar is required: 1:25ft²

Continuous Footing Grade Beam:

1. Dimension, 18" footing width x 12" embedment depth, continuous spread.
2. Footings reinforcement with steel rebar,
 - a. Exterior, 4 #4 rebar, c.c. tied both ways, Splice: 40x
 - b. Interior, 4 #4 rebar, c.c., tied both ways, Splice: 40x

Footing compaction effectiveness: 95% Footing Moisture: Optimum

Clear Span Point Load Column Foundation.

1. Point Load Column: 3.0' x 3.0' x 3.0' column.
Anchor Bolt, minimum 24" U.N.O., 3/4" x 24.0".
Anchor Bolts shall have one washer and one hex nut minimum, Grade A307
2. Column Load Caging
Use #4 rebar grade 60 caged both ways, clear bottom 6.0", 4 mat caged 6.0" elevation.

DWELLING CONCRETE SLAB-ON-GRADE: Vapor Transmission Retarder: Uniform Concrete Curing and Salt Barrier: IBC 1910.1. In areas where dampness would be objectionable, it is recommended that the floor slab be supported on an impermeable moisture barrier. The concrete slab-on-grade should be underlain with a barrier consisting of a minimum 10 mil polyvinyl chloride or equivalent membrane, adequately lapped (6 inch joints not less than 6 inches) placed on top of the select import fill. A minimum two-inch thickness of select washed sand material should be placed over the polyvinyl material for a capillary barrier and to aid in uniform curing of the concrete.

7.3 PATIO COVERS;

A patio cover may be supported on a concrete slab on grade without footings, provided the slab is not less than 3.5 inches (89 mm) thick and further provided that the columns do not support live and dead loads in excess of 750 pounds (3.34 kn) per column. UBC, 1997, Section 3119.

7.4 FORMWORK, FLATWORK (SIDEWALKS ECT.)

Monolithic Pour: Use Portland Type V concrete minimum of 3.0 inches in thickness.

Use of concrete blocks for proper height of the rebar is required: 1:5ft²

Steel Reinforcement: Use #3 rebar, grade 60, 24.0" c.c., tied both ways.

8.0 DYNAMIC SETTLEMENT;

Seismically induced settlement or compaction of dry or moist, cohesion-less soils can also be a secondary effect of earthquake ground motion. Such settlements are typically most damaging when the settlements are differential in nature across the length of the structures.

Some seismically-induced settlement of the proposed structures should be expected as a result of strong motion ground-shaking, however due to the uniform nature of the cohesion-less soils, excessive differential settlement are not expected to occur.

The potential for secondary geologic hazards was evaluated including liquefaction. For this to occur the soil would have to be saturated and loosely compacted. These conditions were not encountered in the investigative excavation to the maximum depth explored. This site is considered to have no liquefaction susceptibility.

9.0 FOUNDATION SETTLEMENT;

Settlement of the foundation system is expected to occur on initial application of loading, the maximum settlement is expected is $S_i = 0.25$ inch and may occur below the heaviest loaded foundation. Differential settlement is not expected to exceed 0.25 inch. Lateral loads may be resisted by computing passive pressure acting against the sides of the footings equal to 200 pcf equivalent fluid pressure. Computing a frictional force between the bottom of the footing and the soil, utilizing a coefficient of friction of 0.35, may also resist lateral load.

10.0 LIMITATIONS

The recommendations specified in this report are subject to the following conditions:

- a. Not Used
- b. The subsurface conditions encountered in the test pit at the time of the site investigation are representative of site conditions.
- c. It is the opinion of the engineer, based on the findings of this investigation that, provided the recommendations presented in this report are followed, the proposed development will be safe for its intended use.
- d. The proposed development will have no adverse effect on the stability of the site or adjoining properties.

11.0 PROFESSIONAL SERVICES: Our professional services were performed using that degree of care and skill ordinarily exercised, under similar circumstances, by reputable geo-technical engineers practicing in this or similar localities. No warranties, either expressed or implied, are intended or made. We prepared this report as an aid in design of the proposed project site use and development. Any contractor reviewing this report must draw his own conclusions regarding site conditions and minimum specific construction techniques to be used on this project.

12.0 CONCLUSIONS: Based on our field exploration, laboratory testing, and engineer's soils properties analysis, it is our opinion that the subject site is suited for development from a Geotechnical engineering and geologic viewpoint. The recommendations herein should be incorporated into the final design, grading and construction phases of development. The analyses performed concerning site preparation and the recommendations presented below, have been completed using the information provided to us regarding site development. In the event that the information concerning proposed development is not correct, the conclusion and recommendations contained in this report shall not be considered valid unless the changes are reviewed and conclusions of this report are modified, in writing by this office.

12.0 REFERENCES

- a. Standard Details and Specifications for Public Improvements within the Pahrump Regional Planning District, June 1, 1999
- b. Guidelines for Design and Review of Development Engineering Submission, February 2005, Samson Yao, PE
- c. Soil Science Society of America, 1994, Part 1-4 Soil Analysis
- d. ASTM International, 2004, Book of Standards.
- e. International Building Code, 2006,
- f. NOT USED
- g. Uniform Plumbing Code, 2006
- h. Nye County Construction Code Title 15.16.17, Updated 9-2005.
- i. Nevada Administrative Code, (NAC)
- j. Nevada Revised Statutes. (NRS)
- k. Shields, et al, 1996, University of Nevada Reno, Shallow Geophysical study of the Pahrump, Valley
- l. Guidelines for Evaluating Potential Surface Fault Rupture/Land Subsidence Hazards in Nevada, Nevada Earthquake Safety Council, 11-20-1998
- m. Stratigraphic analysis from borehole data of tertiary basin-filling rocks of the Pahrump Valley basin, Donald Sweetkind, Taylor, Putnam
- n. NCC Bill 2006-15, 15.16.075, Effective 8-7-06

**APPENDIX D
PUMP AND FORCE MAIN HYDRAULICS**





Spring Mountain Motorsports Ranch
Sewage Pump Station - Force Main

Date 2/5/2015
Job Number 1520359
Revision 3/15/2016
@ C ≈ 134

SYSTEM HEAD CURVE HYDRAULIC CALCULATIONS - FORCE MAIN LINE LOSSES AND MINOR LOSSES

	For Max TDH			For Min TDH	
	Low Tank level			High Pond Level	
Plant Discharge @ Screen	2815	Screen is ≈ 5 ft. above surface			4.046 in for 4 inch DR 21
ELEV. WS in Wet Well	2757.5	Low WS EL.	4-15-2015 Draft Plans		5.957 in for 6 inch DR 21
STATIC HEAD	57.50				5.798 dr 17

6 in DR 17-Lift Station to Plant 100 psi		4 inch DI header to HDPE		not used	
LINE DIAMETER (D) IN.	5.798	DIAMETER	4.175	DIAMETER	1000
AREA (A) SQ.FT.	0.183	AREA (A)	0.095	AREA (A)	5454.154
LINE LENGTH (L) FEET	2337	LENGTH	15	LENGTH	0.1
FRICITION FACTOR (f)	0.02089	FRICITION	0.018	FRICITION	0.023
APPROX. "C" EQUIV.	134	APPROX. "C"	141	APPROX. "C"	193
Elevation @ End of Segment		ELEVATION		ELEVATION	

MINOR LOSSES	SEGMENT	5.798 INCH LINE		4.175 INCH LINE		1000 INCH LINE	
		NO. UNITS	SUM (k)	NO. UNITS	SUM (k)	NO. UNITS	SUM (k)
FITTING	k FACTOR						
GATE VALVES	0.20		0		0		0
PLUG VALVES	0.80		0	1	0.8		0
CHECK VALVE	2.50		0		0		0
90 LONG RADIUS EL	0.18		0		0		0
90 MEDIUM RADIUS EL	0.25	6	1.5		0		0
45 LONG RADIUS EL	0.14		0		0		0
45 MEDIUM RADIUS EL	0.19		0		0		0
90 TEE	1.80	1	1.8		0		0
RUN OF TEE	0.60		0		0		0
WYES	1.00		0	1	1		0
BELL MOUTH ENTRANCE	0.05		0		0		0
FLUSH PIPE ENTRANCE	0.50		0		0		0
REDUCER	0.04		0		0		0
INCREASER	0.25		0	1	0.25		0
METER (Mag. straight run)	0.60		0	1	0.6		0
OUTLET	1.00	1	1		0		0
					0		
TOTAL k FACTORS	10.1		4.3		2.65		0

LOSS = {f*L/(D/12) + SUM(k)}(V^2/2G)

TOTAL FRICTION LOSSES	Max. TDH	in DR 17-Lift Station to Plant 100 p		4 inch DI header to HDPE		not used	
	Low Wet	5.798 " LINE		4.175 " LINE		1000 " LINE	
FLOW INCREMENT	System Curve	SEGMENT		MAIN		MAIN	
25	TDH	VELOCITY	HEAD LOSS	VELOCITY	HEAD LOSS	VELOCITY	HEAD LOSS
Q in GPM	FEET	FT/SEC	FEET	FT/SEC	FEET	FT/SEC	FEET
0.00	57.50	0.00					
25.00	57.67	0.30	0.15	0.59	0.02	0.00	0.00
50.00	58.18	0.61	0.60	1.17	0.07	0.00	0.00
75.00	59.02	0.91	1.36	1.76	0.16	0.00	0.00
100.00	60.21	1.22	2.42	2.34	0.29	0.00	0.00
125.00	61.73	1.52	3.77	2.93	0.46	0.00	0.00
150.00	63.59	1.82	5.44	3.52	0.66	0.00	0.00
175.00	65.79	2.13	7.40	4.10	0.89	0.00	0.00
200.00	68.33	2.43	9.66	4.69	1.17	0.00	0.00
225.00	71.21	2.73	12.23	5.27	1.48	0.00	0.00
250.00	74.42	3.04	15.10	5.86	1.83	0.00	0.00
275.00	77.98	3.34	18.27	6.45	2.21	0.00	0.00
300.00	81.87	3.65	21.74	7.03	2.63	0.00	0.00
325.00	86.10	3.95	25.52	7.62	3.09	0.00	0.00
350.00	90.67	4.25	29.59	8.20	3.58	0.00	0.00
375.00	95.58	4.56	33.97	8.79	4.11	0.00	0.00
DESIGN POINT	57.50						
287.00	79.80	3.49	19.90	6.73	2.41	0.00	0.00
	34.59	psi					

HP Calculation			
Specified Q	287	gpm	
TDH From Modified Speed or Imp. Dia.	87	ft.	Select from pump curve based on Q above.
% Efficiency	60%		
HP	11	HP	Curve Run out HP = Motor is 12 HP



Spring Mountain Motorsports Ranch Sewage Pump Station - Force Main

Date 2/5/2015
 Job Number 1520359
 Revision 7/10/2015

MANUFACTURERS PUMP CURVE AND CURVE CORRECTION FOR INDIVIDUAL PUMP SUCTION & DISCHARGE LOSSES INCLUDING VARIABLE SPEED CALCULATIONS

PUMP CURVE AND CURVE CORRECTION CALCULATIONS.	Individual Pump Suction & Discharge Calculation - Pump Curve Loss Corrections			
	Individual Pump Suction		Individual Pump Discharge	
DIAMETER	1000		DIAMETER	4.175
AREA (A)	5454.154		AREA (A)	0.095
LENGTH	0.0001		LENGTH	30
FRICTION	0.02		FRICTION	0.021
Approx. C factor	208			130

1000 IN. LINE

4.175 IN. LINE

FITTING	k FACTOR	NO. UNITS	SUM (k)	NO. UNITS	SUM (k)
GATE VALVES	0.20		0		0
PLUG VALVES	0.80		0	1	0.8
CHECK VALVE	2.50		0	1	2.5
90 LONG RADIUS EL	0.18		0		0
90 MEDIUM RADIUS EL	0.25		0	2	0.5
45 LONG RADIUS EL	0.14		0		0
45 MEDIUM RADIUS EL	0.19		0	2	0.38
90 TEE	1.80		0	1	1.8
RUN OF TEE	0.60		0		0
WYES	1.00		0		0
BELL MOUTH ENTRANCE	0.05		0		0
FLUSH PIPE ENTRANCE	0.50		0		0
REDUCER	0.04		0		0
INCREASER	0.25		0	1	0.25
METER	0.60		0		0
OUTLET	1.00		0		0
		1000 INCH LINE	0	4.175 INCH LINE	6.23

FLOW INCREMENT 100	Pump Curve Loss Corrections				Flygt NP 3153 HT 3-464			
	Individual Pump Suction		Individual Pump Discharge					
	1000 " LINE		4.175 " LINE		Trim = 253 mm			
FLOW IN GPM FOR PUMP	SINGLE	VELOCITY	HEAD LOSS	VELOCITY	HEAD LOSS	Input Mfg. Curve HEAD One Pump	Modified Curve Minus Suct. Disch. Loss	Flow Two Pumps
		FT/SEC	FEET	FT/SEC	FEET			
0		0.00	0.00	0.00	0.00	123	123.00	0
100		0.00	0.00	2.34	0.69	104	103.31	200
200		0.00	0.00	4.69	2.74	94	91.26	400
300		0.00	0.00	7.03	6.17	86	79.83	600
400		0.00	0.00	9.37	10.97	77	66.03	800
500		0.00	0.00	11.72	17.15	69	51.85	1000
		0.00	0.00	0.00	0.00			0
		0.00	0.00	0.00	0.00			0
		0.00	0.00	0.00	0.00			0
		0.00	0.00	0.00	0.00			0
		0.00	0.00	0.00	0.00			0
		0.00	0.00	0.00	0.00			0
		0.00	0.00	0.00	0.00			0
		0.00	0.00	0.00	0.00			0
		0.00	0.00	0.00	0.00			0
Single Pump Design Point 287		0.00	0.00	6.73	5.65			

Spring Mountain Motorsports Ranch Wastewater Pump Station
System Curves Flygt NP 3153 HT 3-464 - 253 mm

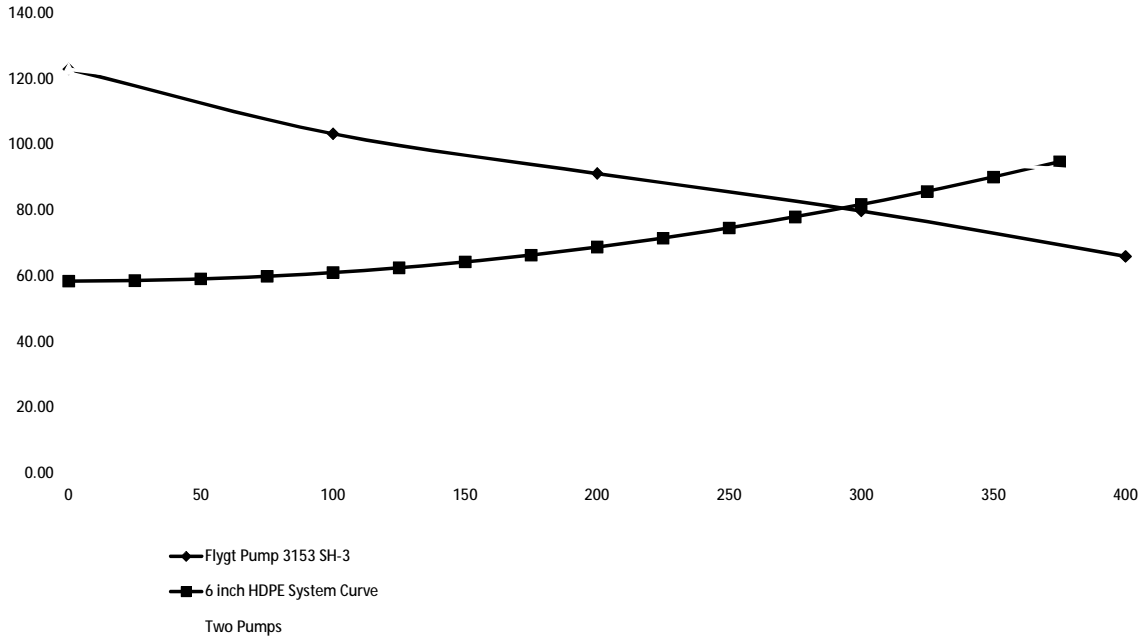

NP 3153 HT 3~ 464 Technical specification

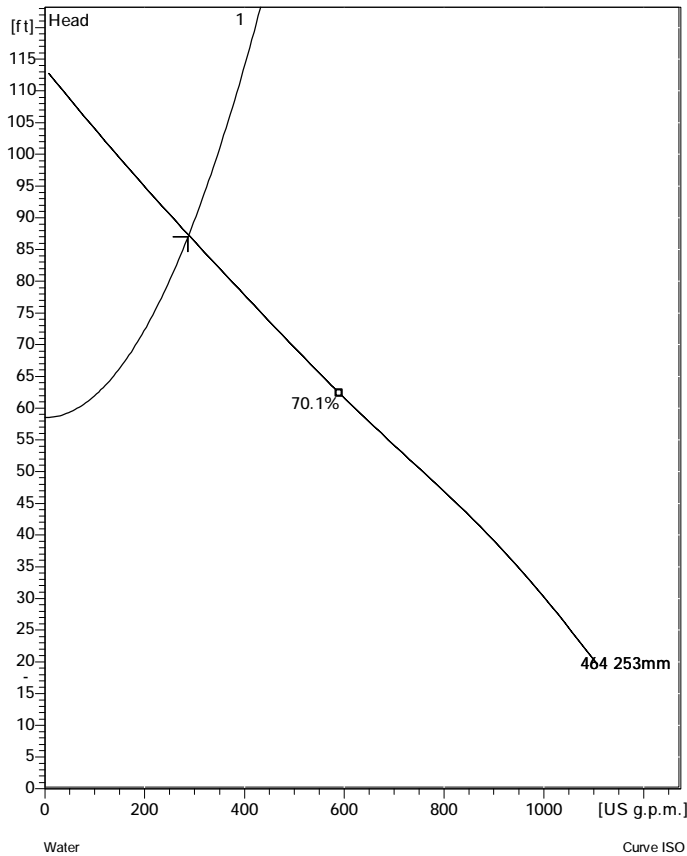

Note: Picture might not correspond to the current configuration.

General
Patented self cleaning semi-open channel impeller, ideal for pumping in waste water applications. Possible to be upgraded with Guide-pin® for even better clogging resistance. Modular based design with high adaptation grade.

Impeller

Impeller material	Hard-Iron™
Discharge Flange Diameter	3 15/16 inch
Inlet diameter	3 15/16 inch
Impeller diameter	253 mm
Number of blades	2

Motor

Motor #	N3153.095 21-15-4AA-W 15hp
Stator variant	1
Frequency	60 Hz
Rated voltage	460 V
Number of poles	4
Phases	3~
Rated power	15 hp
Rated current	19 A
Starting current	112 A
Rated speed	1755 rpm
Power factor	
1/1 Load	0.84
3/4 Load	0.78
1/2 Load	0.67
Efficiency	
1/1 Load	87.0 %
3/4 Load	88.5 %
1/2 Load	88.0 %

Configuration

Installation: P - Semi permanent, Wet

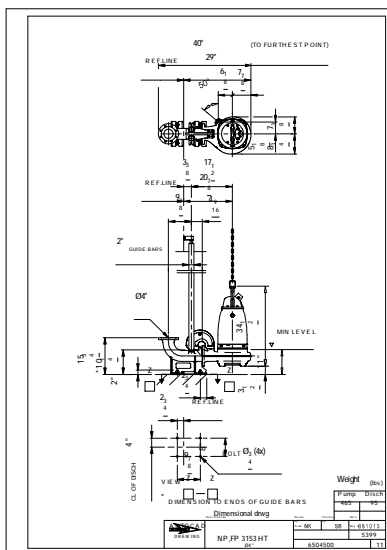

Project

Project ID
Spring Mtn Motor Sports Ranch LS

Created by
David Hutchinson

Created on
2016-03-05 01:44

Last update
2016-03-05 02:35:20

NP 3153 HT 3~ 464

Performance curve



Pump

Discharge Flange Diameter 3 15/16 inch
 Inlet diameter 100 mm
 Impeller diameter 9 15/16"
 Number of blades 2

Motor

Motor # N3153.095 21-15-4AA-W 15hp
 Stator variant 1
 Frequency 60 Hz
 Rated voltage 460 V
 Number of poles 4
 Phases 3~
 Rated power 15 hp
 Rated current 19 A
 Starting current 112 A
 Rated speed 1755 rpm

Power factor
 1/1 Load 0.84
 3/4 Load 0.78
 1/2 Load 0.67
 Efficiency
 1/1 Load 87.0 %
 3/4 Load 88.5 %
 1/2 Load 88.0 %

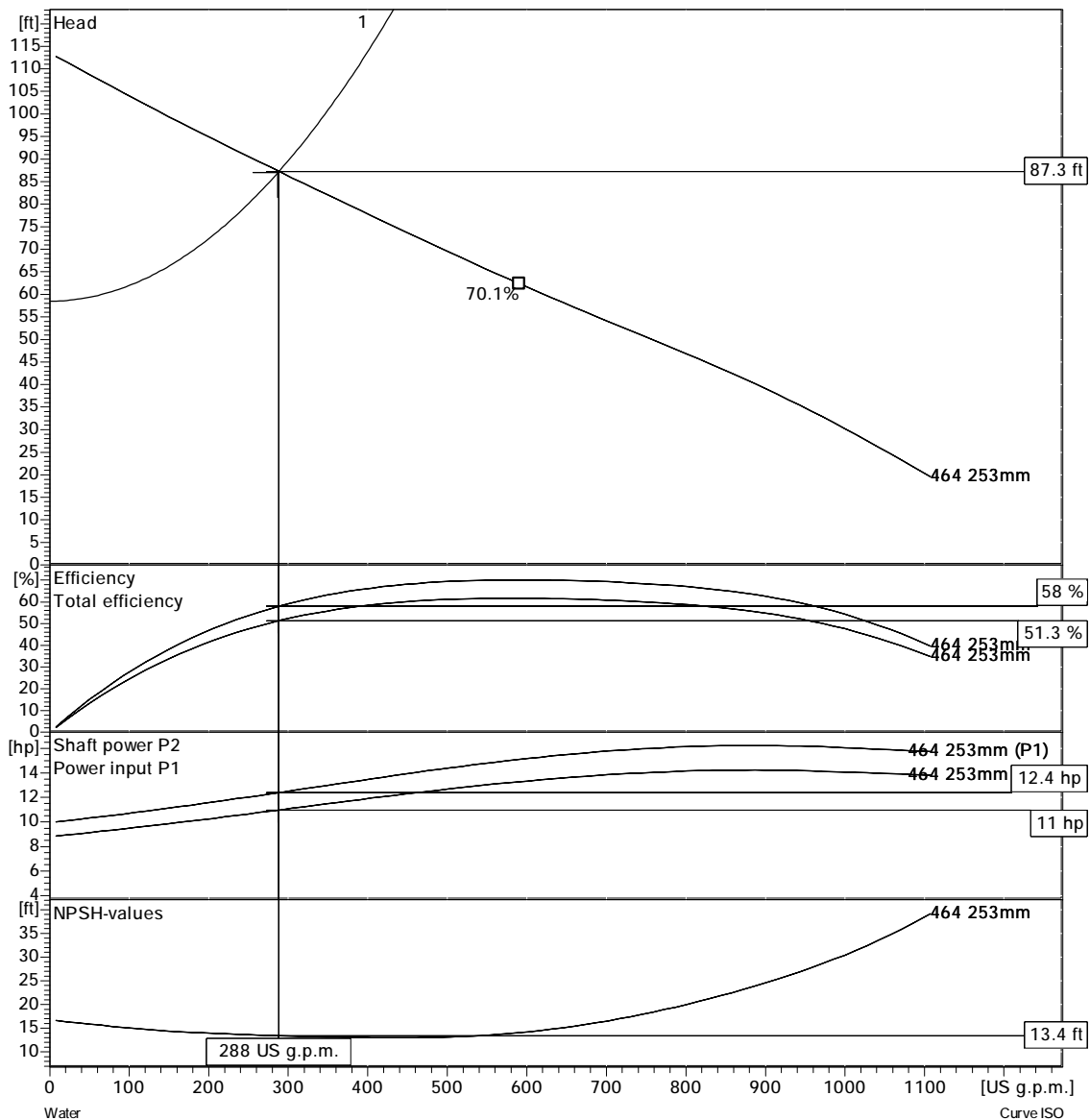

Project

Project ID
 Spring Mtn Motor Sports Ranch LS

Created by
 David Hutchinson

Created on
 2016-03-05 01:44

Last update
 2016-03-05 02:35:20

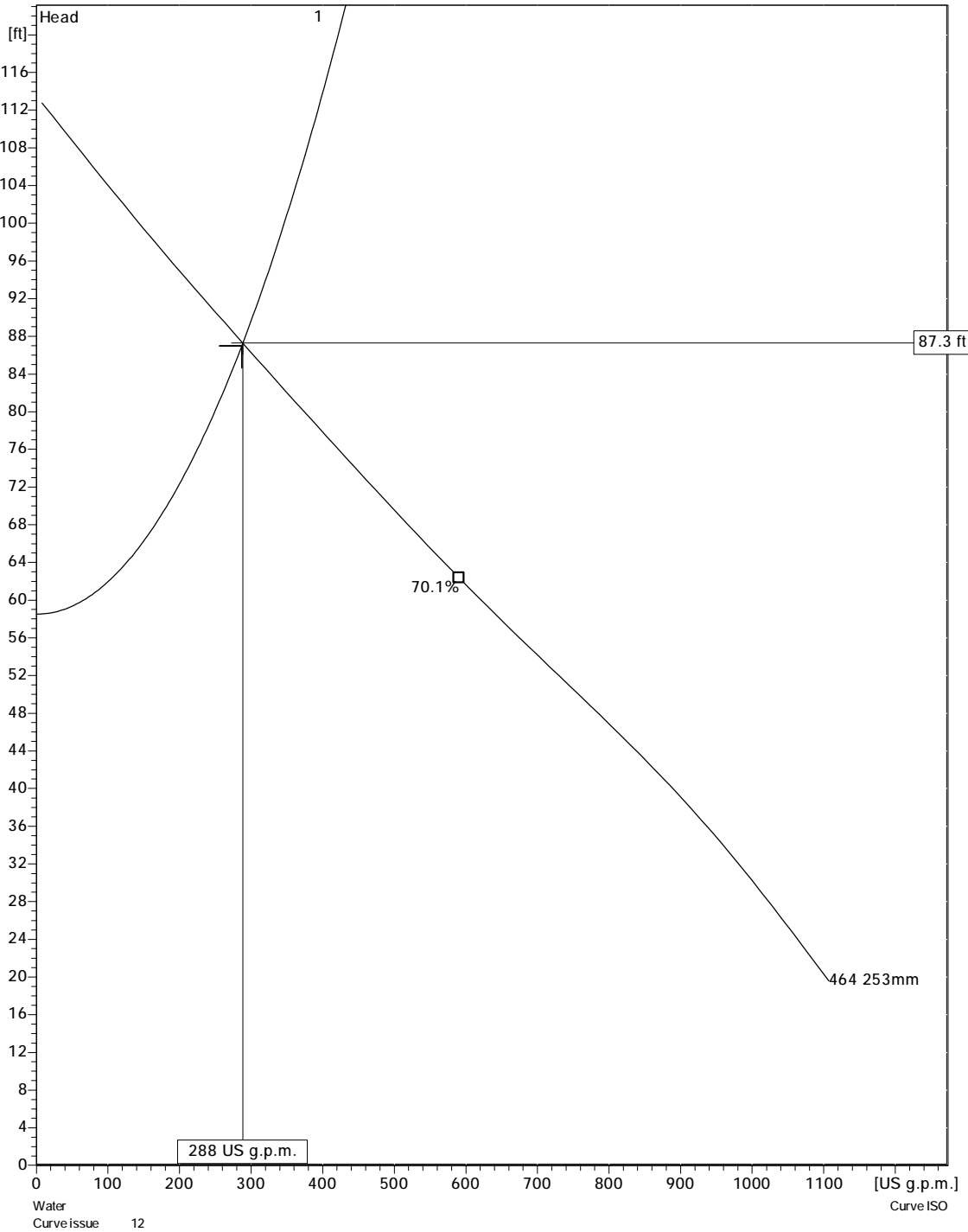

Pumps running /System	Individual pump			Total					
	Flow	Head	Shaft power	Flow	Head	Shaft power	Pump eff.	Specific energy	NPSHre
1	288 US g.p.m.	87.3 ft	11 hp	288 US g.p.m.	87.3 ft	11 hp	58 %	534 kWh/USMG	13.4 ft

Project

Project ID
Spring Mtn Motor Sports Ranch LS

Created by
David Hutchinson

Created on
2016-03-05 01:44:20

Last update
2016-03-05 02:35:20

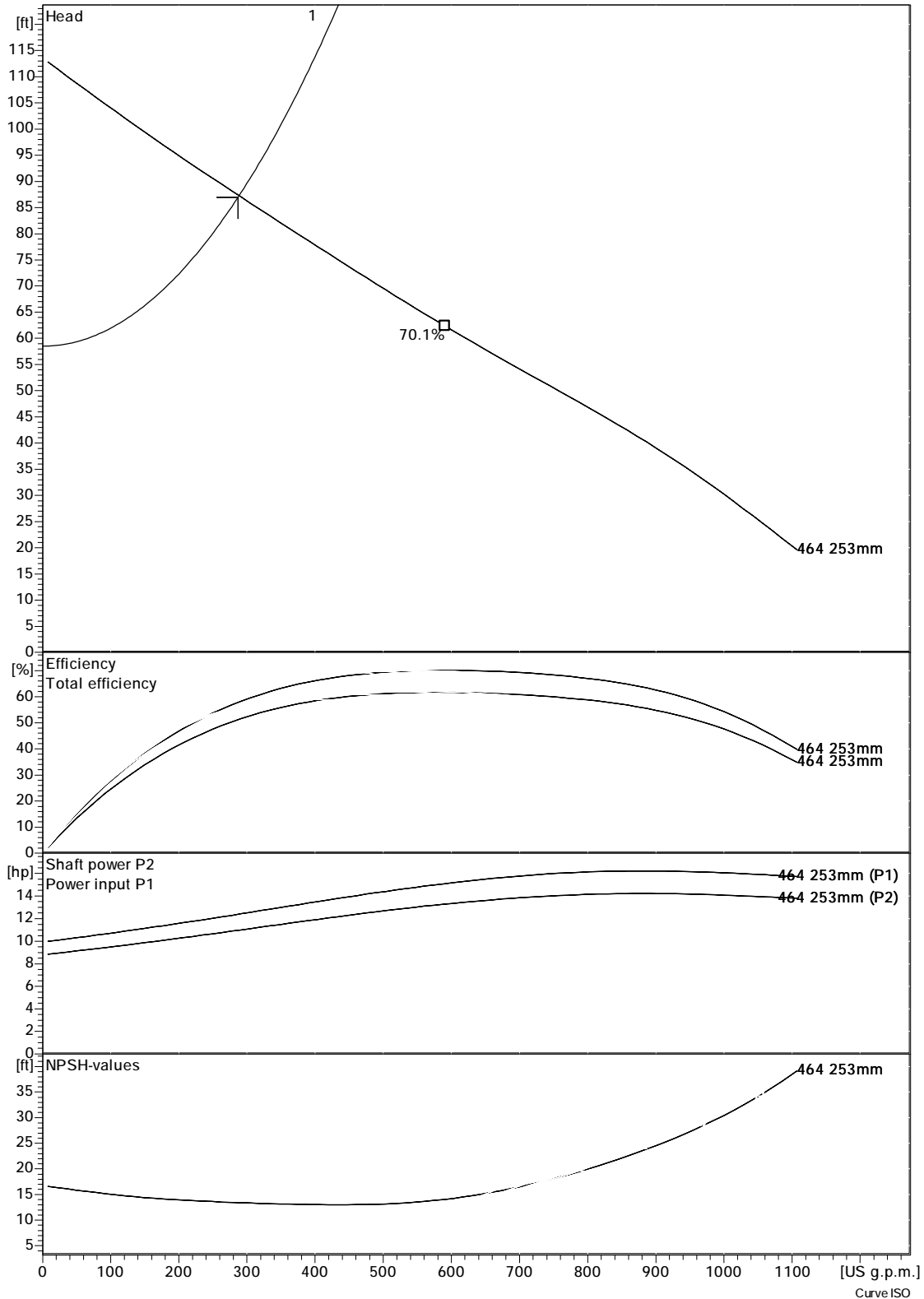

Project

Project ID
Spring Mtn Motor Sports Ranch LS

Created by
David Hutchinson

Created on
2016-03-05 01:44:20
Last update
2016-03-05 02:35:20

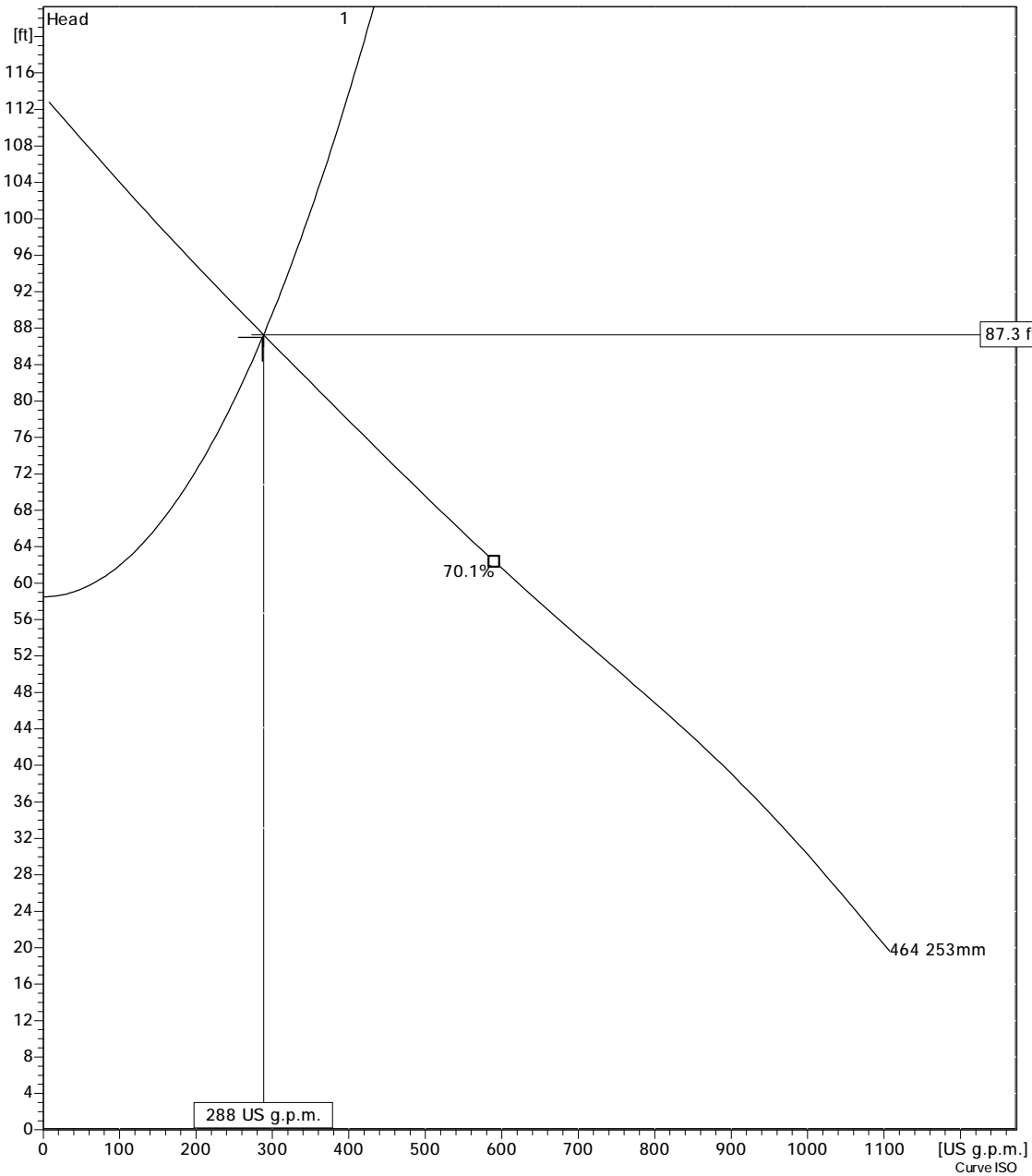

Pumps running /System	Frequency	Flow	Head	Shaft power	Flow	Head	Shaft power	Hyd eff.	Specific energy	NPSHre
1	60 Hz	288 US g.p.m.	87.3 ft	11 hp	288 US g.p.m.	87.3 ft	11 hp	58 %	534 kWh/US MG	13.4 ft
1	55 Hz	224 US g.p.m.	75.9 ft	8.09 hp	224 US g.p.m.	75.9 ft	8.09 hp	53.1 %	507 kWh/US MG	11.8 ft
1	50 Hz	152 US g.p.m.	66.5 ft	5.79 hp	152 US g.p.m.	66.5 ft	5.79 hp	44.1 %	544 kWh/US MG	10.5 ft
1	45 Hz	54.4 US g.p.m.	59.5 ft	3.88 hp	54.4 US g.p.m.	59.5 ft	3.88 hp	21.1 %	1060 kWh/US MG	9.71 ft
1	40 Hz									

Project

Project ID
Spring Mtn Motor Sports Ranch LS

Created by
David Hutchinson

Created on
2016-03-05 01:44:20

Last update
2016-03-05 02:35:20

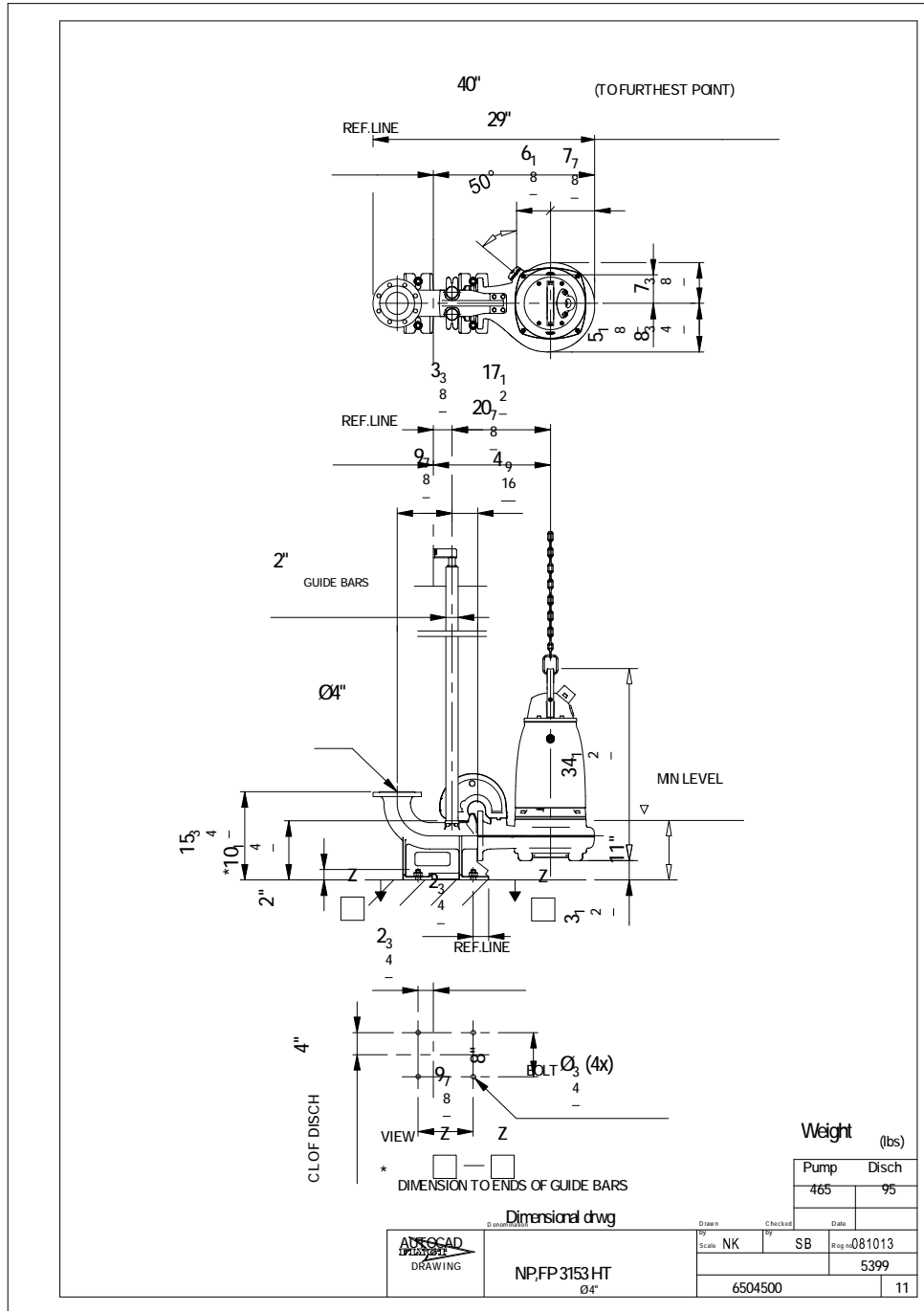

Project

Project ID
Spring Mtn Motor Sports Ranch LS

Created by
David Hutchinson

Created on
2016-03-05 01:44

Last update
2016-03-05 02:35:20

APPENDIX E
PUMP CYCLE AND WET WELL BOUYANCY CALCULATIONS





PUMP CYCLE CALCULATIONS

Date: March 25, 2015
Project No.: 1520359
Subject: Lift Station Pump Cycle Time
Project Title: Spring Mountain Motorsports Ranch

Made by: AJS
Checked by: JC
Reviewed by: MB

1.0 Objectives

To calculate the time between successive pump starts.

2.0 Given

Golder has obtained the following lift station data from the Drawings and Design Report:
 The minimum cycle time occurs when the incoming flow is one-half of the pump flow rate.

Lift station diameter (ft) =	5.00
Elevation of the lead Pump-on in the wet well (ft) =	2,758.00
Elevation of the Pump-off level of the wet well (ft) =	2,755.00
Height of wet well that contains available storage during normal operation (ft) =	3.00
Design flow rate factor for miniumun cyle time =	0.50
Pump design flow rate (gpm) =	287.0

3.0 Calculations

Volume of lift station available during normal pumping event (gallons) =	440.64
Time until wet well empties during factored flow (minutes) =	3.1
Time until wet well fills during factored flow (minutes) =	3.1
Minimum time between successive starts (minutes) =	6.1
Time between successive starts with alternating Lead/Lag pumps (minutes) =	12.3
Number of pump starts per hour =	4.9

Date: March 6, 2015
Project No.: 1520359
Subject: Pump Station Wet Well Bouyancy Calculations

Made by: AJS
Checked by: JC
Reviewed by: MB

1.0 Objectives

To determine the required weight and geometry of the concrete ballast for the fiberglass pump lift station to prevent floating.

2.0 Given

Golder has obtained the following fiberglass lift station data from the drawings:

Height of 5 ft diameter section of the fiberglass lift station (ft) =	17.49
Lift station diameter (ft) =	5.00
Height of variable diameter section of the fiberglass lift station (ft) =	1.74
Lift station diameter at the bottom (ft) =	1.66

3.0 Assumptions

Golder has made the following assumptions for this calculation:

Depth from the ground surface to the water table (ft) =	0.00
Saturated unit weight of backfill (pcf) =	130.00
Effective unit weight of backfill (pcf) =	67.60
Concrete density (lb/ft ³) =	145.00

4.0 Calculations

Volume of fiberglass lift station with 5 ft diameter (ft ³) =	343.42
Volume of fiberglass lift station with variable diameter (ft ³) =	16.42
Volume of fiberglass lift station susceptible to floating (ft ³) =	359.84
Bouyant weight of the lift station (lb) =	22,454

Since the concrete will be placed around the collar of the lift station, the width and height of this ballast must be determined along with the weight of the resisting soil above it. The height of concrete ballast was selected at 1 ft.

Inner radius of concrete ballast (ft) =	2.50
Outer radius of concrete ballast (ft) =	4.00
Height of concrete ballast (ft) =	1.00
Weight of concrete ballast (lb) =	4,441
Height of soil above the concrete ballast (ft) =	16.00
Weight of soil above the concrete ballast (lb) =	33,130
Required outer radius of concrete ballast (lb/ft ³) =	33,130
Bouyant weight of the lift station (lb) =	22,454
Resisting Weight of the lift station (lb) =	37,571
Factor of Safety =	1.50
Will the lift station ever float?	no

Established in 1966, Golder Associates is a global, employee-owned organization that helps clients find sustainable solutions to the challenges of infrastructure, energy and water supply and management, waste management, transportation, and climate change. We provide a wide range of independent consulting, design, and construction services in our focused areas of earth, environment, and energy. By building strong relationships and meeting the needs of clients, our people have created one of the most trusted professional services organizations in the world.

Asia + 852 3432 8888
Australia + 61 2 9550 2000
Europe + 33 20 42 52 20
North America + 1 800 370 3000
South America + 56 2 2000 2000

info@golder.com
www.golder.com

Golder Associates Inc.
595 Double Eagle Ct., Suite 1000
Reno, NV 89521
Tel: 775-828-9604
Fax: 775-828-9645



Engineering Earth's Development, Preserving Earth's Integrity

Golder, Golder Associates and the GA globe design are trademarks of Golder Associates Corporation

Limestone Gravel Pack Report



9222 Prototype Drive
Reno, NV 89521
Tel: 775.827.6111
Fax: 775.827.6122
www.lumosinc.com

DATE: October 31, 2018
TO: James Eason
FROM: Michael Hardy, P.E., P.G., WRS
CC: Tim Scheidt, Bill Coates, Mark Windholz
SUBJECT: Gravel Pack Material Test from Spring Mountain Borrow Pit Source

INTRODUCTION

Great Basin Water Co. – Pahrump Division (GBWC-PD) owns and operates five water systems in Pahrump Nevada. Recently, they have initiated a rehabilitation program of the wells that supply the water systems to return production capacity to the wells. The rehabilitation of the wells involve an acid chemical treatment to dissolve mineral deposits in the screens and gravel pack. After conducting an acid treatment to their Well 11, it was brought to GBWC-PD attention that most of their existing wells were constructed using a limestone gravel pack source. The material source came from the Spring Mountain Borrow Pit, known to contain a high percentage of limestone aggregate. Since GBWC-PD recent initiation of the rehabilitation program, they were concerned about the effects of acid treatments on wells with a high percentage of limestone in the gravel pack. Their concerns include the possibility of dissolving a portion of the gravel pack in wells without the ability to replace the gravel, since the wells do not have gravel feed tubes. GBWC-PD asked Lumos & Associates, Inc. (Lumos) to run a test, using gravel collected from the Spring Mountain Borrow Pit, which simulates the acid treatment procedures used to clean their wells. The objectives of the test was to determine how the gravel pack and treatment process might be affected due to the high limestone concentrated gravel pack. Limestone is composed of Calcium Carbonate (CaCO_3), which is considered a base (buffer) used to neutralize acid. When limestone is introduced into an acid solution, the CaCO_3 reacts with the acid bring the pH from an acidic value closer to the neutral pH of 7.0. Depending on the type and concentration of the acid, the pH of the acid solution can be partially or completely neutralized.

TESTING PROTOCOL

GBWC-PD collected two 5-gallon buckets of source material from the Spring Mountain Borrow Pit located in Pahrump, NV. The samples were transported by GBWC personnel to Lumos' Reno Lab in June 2018. Lumos screened the material, saving all the aggregate retained on the #4 through #12 sieve sizes. This granular size is believed to best represent the gravel pack used for most of the wells owned by GBWC-PD. Next Lumos designed a makeshift well out of plastic cylinders. A 4" X 7.5" cylinder was used to replicate the well casing screen and a 6" X 12" cylinder was used to replicate the borehole. The 4" X 7.5" was perforated with vertical slots and placed inside the 6" X 12" cylinder (See Appendix A). The annular space between the two cylinders was filled with the 4 X 12 gravel pack and then removed to obtain a dry weight. Once the simulated well was created, a weighted volume of the gravel pack was placed in the annulus space between the two cylinders to create the finished test well. Lumos obtained a standard concentrated mixture of muriatic acid (hydrochloric

acid) with corrosion inhibitor from a local drilling company who conducts this type of acid cleaning on a regular basis. The corrosion inhibitor is added to the acid to reduce the acids ability to corrode the steel casing, only reacting with the mineral deposits in the screen slots and gravel pack.

As a field application, the drilling company would calculate out the well and borehole volumes and inject a 1:1 ratio of the standard acid concentration into the well and then swab the well and allow the acid concentration to dissolve the mineral deposits in the screen intervals. The acid concentration would remain in the well until the pH reached a level greater than 5.0. Usually, it would take between 24 and 48 hours for the acid concentration to reach a pH of greater than 5.0. To simulate this methodology, Lumos diluted the muriatic acid concentration to a 1:1 ratio (acid to water) and poured the solution into the model test well. The liquid was then swabbed periodically, using a single-disk plunger tool, to ensure that the chemicals mixed thoroughly with the gravel pack (See Appendix A). Lumos used a HI 9813-6 Portable pH/EH/TDS/C Field Meter manufactured by Hanna Instruments to collect pH reading of the acid solution prior to and during the test. A pH read was collected prior to pouring the chemical concentration into the simulated well model. The initial pH of the acid solution was 0.6. Additional readings were collected throughout the test following each time the well model was swabbed. Table-1 contains the pH readings and times collected throughout the test.

Table-1: Laboratory Data Collected During Testing.

DATE	TIME	pH
10-8-18	8:50 AM (prior to starting test)	0.6
10-8-18	10:30 AM	3.2
10-8-18	11:20 AM	4.4
10-8-18	4:22 PM	4.9
10-9-18	7:01 AM	5.3
10-9-18	12:10 PM (Stopped)	5.6

The acid concentration reached a pH level of greater than 5.0 sometime after 4:22 pm the first day. This rapid increase in pH over less than a 24-hour period is believe to be due to the high concentration of limestone gravel pack material neutralizing the acid. When the acid solution was first introduced in to the gravel pack, a heavy reaction, involving fizzing, occurred for several minutes. Every time the swabbing tool was used to mix the acid throughout the gravel pack in the well model, the fizzing reaction would reoccur. At the termination of the test, the acid solution was evacuated from the simulated well along with the gravel pack. The gravel pack was rinsed in tap water, dried, and once again weighed. Sieve analyses were conducted on the treated and non-treated gravel pack for comparison.

ANALYSIS

The weight of the gravel pack prior to the acid treatment was 2,803.7 grams. Following the acid treatment, the weight of the gravel pack was 2,769.7 grams. This equates to a total loss of 34 grams or 1.21 percent of the gravel pack. Table-2 contains the pre- and post- weights and percent loss of material.

Table-2: Weight of gravel prior to and after acid treatment

Prior to Acid Treatment (grams)	Post Acid Treatment (grams)	Percent Lost (%)
2803.7 g	2769.7 g	1.21

A sieve analysis was conducted on the gravel pack following the acid treatment to see how the particle sizes of the gravel changed once it was acid treated. Table-3 contain the two sieve analyses of the gravel pack prior

to and after the acid treatment. The two sieve analyses suggest that the smaller granular sizes were more readily affected by the acid treatment. The smaller the particle size, the more of an effect the acid treatment created. The largest change occurred to the #8 and #10 sieve particle sizes. It also appears that the percentage of particles on the #12 sieve may have been increased due to the partial dissolving or shrinkage of pre #10 sieve particles. There is a possibility that the smaller particle sizes had a higher percentage of limestone than the larger particle sized resulting in this larger change in the gravel pack. Another possibility is that the increased percentage of surface area associated with the smaller particle size makes it more susceptible to the acid.

Table 3: Sieve Analysis of Gravel Pack Prior and After Acid Treatment

U.S. Std. Sieve Sizes	Percent Passing (Non-Acid Treated)	Percent Passing (Acid Treated)	Percent Change (%)
1/2"	100	100	0
3/8"	99	98	≈0
#4 (0.187")	39	46	18
#8 (0.0937")	5	13	160
#10 (0.0787")	2	6	200
#12 (0.0661")	0.8	0.5	-38

CONCLUSIONS AND RECOMMENDATIONS

The two main observations created by the acid treatment of the simulated well with a limestone gravel pack were a reduced cleaning on the mineral deposit build up and the reduction in the particle size of the gravel pack. The limestone gravel pack neutralized the acid at an accelerated rate resulting in substandard cleaning of the mineral deposits in the well screen and gravel pack. The neutralization of the acid by the gravel pack resulted in reducing the particle size of the gravel pack, especially in the finer granules. Since an acid treatment to a well with a limestone based gravel pack only has a moderate ability to properly clean the well, Lumos recommends looking into alternative cleaning methods, like Aqua Freed (liquid CO₂ injections), that have the ability to generate the chemical and mechanical treatments necessary to remove mineral deposits. In addition, a non-acid based type of chemical treatment would not have the detrimental effects of dissolving the gravel pack.

Michael Hardy, P.E., P.G., WRS

APPENDICES

Appendix-A: Photos of the Equipment Used to Simulate the Acid Treatment of a Well.

Appendix-B: Aqua Freed Well Cleaning Process

APPENDIX A
(PHOTOS OF THE EQUIPMENT USED FOR THE GRAVEL PACK EXPERMENT)



Photo of the borehole cylinder, well cylinder, and plunger



Photo of the 6" X 12" Cylinder used for the borehole of the well.



Photo of 4" X 7.5" cylinder used as the screen for the Well (vertical perforations).

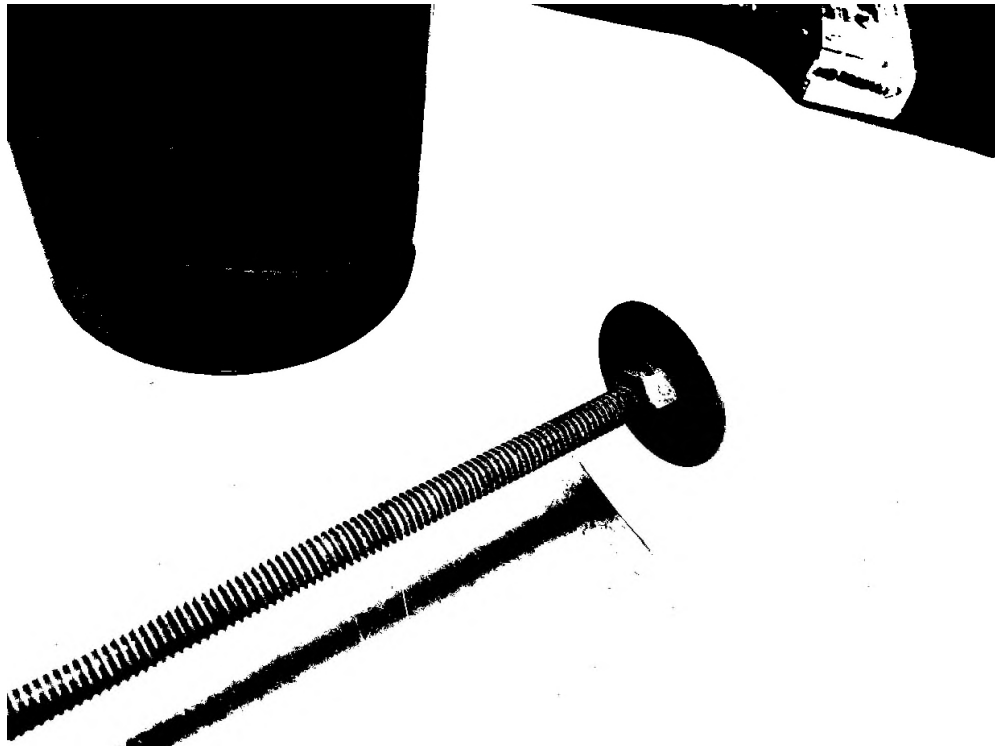

Photo of the Plunger used as the swabbing tool to circulate the acid.



Photo of assembled well model with gravel pack installed

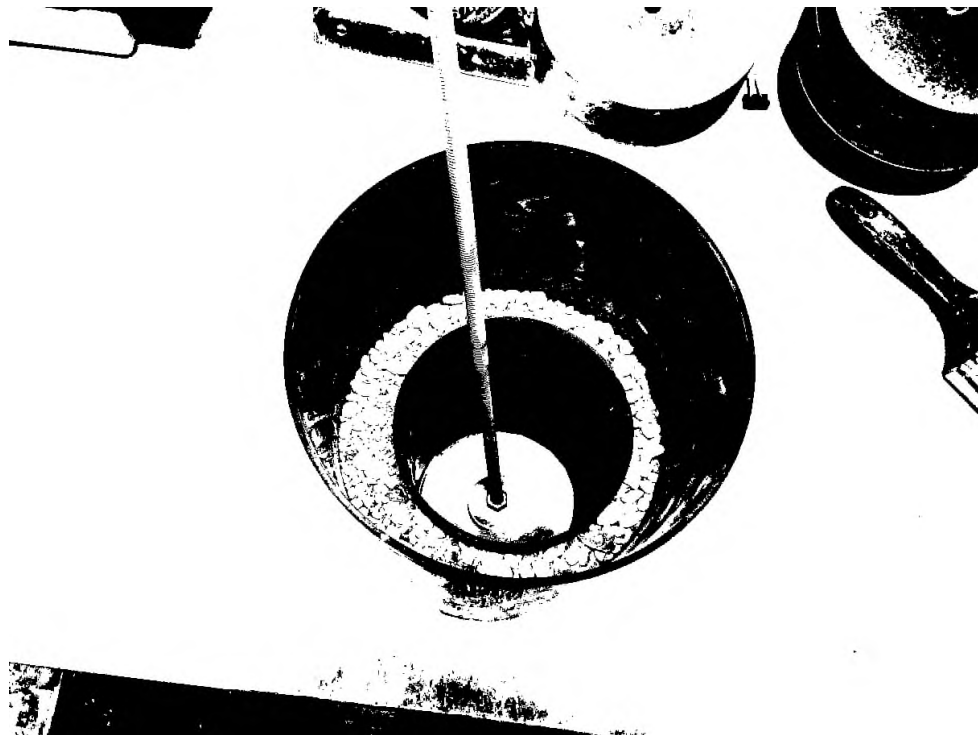

Photo of assembled well model with plunger inside screen

APPENDIX B
(AQUA FREED WELL CLEANING PROCESS)

Step One:
Aqua Freed® personnel study the well data to determine the correct placement of the packer. After the pump is pulled, a packer is inserted to the desired depth to confine and direct the carbon dioxide to the treatment area. Then, gaseous carbon dioxide is injected through the packer into the well, producing a highly abrasive carbonic acid solution and penetrating far into the surrounding formation.



Step Two:
Liquefied carbon dioxide is injected at various temperatures and pressures. When the liquefied carbon dioxide comes in contact with the water, it expands rapidly, producing tremendous agitation. The continued, controlled injection of the liquefied carbon dioxide produces the energy necessary to detach, dislodge and remove mineral encrustation, biological fouling and physical plugging.

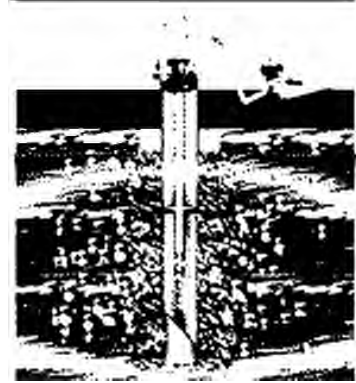

Step Three:
After treatment with gaseous and liquid carbon dioxide, the well is mechanically developed using surge/airlift methods to remove the newly dislodged particulate matter from the well and formation.

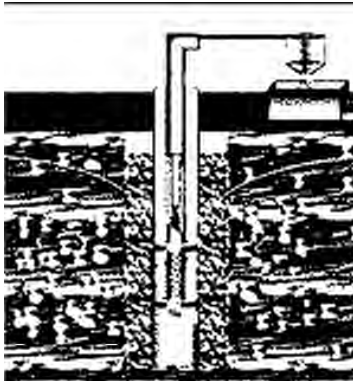

Step Four:
The well pump is then reinstalled and the well is tested and returned to service, providing an increased supply of water for its intended use.

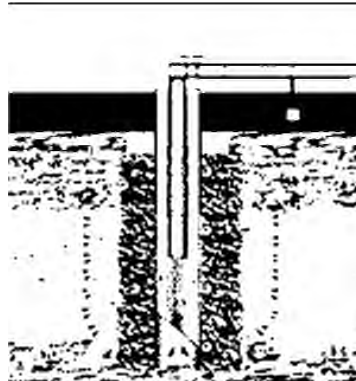

FINAL DESIGN REPORT

Wastewater Treatment Plant

Spring Mountain Motorsports Ranch

Submitted To: Russ Meads
Double M Construction
P.O. Box 6498
Pahrump, Nevada 89041-6498

Submitted By: Golder Associates Inc.
595 Double Eagle Court, Suite 1000
Reno, NV 89521 USA

Distribution: Joe Maez, NDEP-BWPC (2 copies)
Russ Meads, Double M Construction (1 copy)
Wendy Barnett, UICN (1 copy)
Golder Associates (1 copy)

May 4, 2016

Project No.1520359



Golder, Golder Associates and the GA globe design are trademarks of Golder Associates Corporation

**Final Design Report
Wastewater Treatment Plant
Spring Mountain Motorsports Ranch
Pahrump, Nevada**

The following design report has been prepared by the staff of Golder Associates Inc. under the professional supervision of the engineers whose signatures appear herein.

The findings, design, and recommendations presented in this report were presented within the limits described by Double M Construction, after being prepared in accordance with generally accepted professional engineering principles and practices.



Michael P. Bidart, PE
Project Manager

John E. Connell
Senior Consultant

Andrew Schaper, PE
Project Engineer

Table of Contents

1.0	INTRODUCTION.....	1
1.1	Project Description	1
2.0	DESIGN CRITERIA.....	2
2.1	Siting Criteria.....	2
2.2	Influent Characterization	2
2.3	Effluent Limitations.....	3
2.4	Odor Control.....	3
2.5	WWTP Design.....	4
2.5.1	Package Plant Data	4
2.5.2	Screening.....	4
2.5.3	Equalization Basin	5
2.5.4	Anoxic Reactors.....	5
2.5.5	Grit Removal	5
2.5.6	Aeration Basin.....	5
2.5.7	Settling	5
2.6	Filtration.....	6
2.7	Disinfection.....	6
2.8	Solids Management	6
2.9	Back-up Power	7
2.10	Effluent Disposal	8
2.10.1	Infiltrometer Results	8
2.10.2	RIB Design Criteria	8
3.0	DRAWINGS AND TECHNICAL SPECIFICATIONS.....	10
4.0	WASTEWATER TREATMENT FACILITY OPERATIONS.....	11



List of Tables

Table 1	Influent Wastewater Characterization
Table 2	Secondary Clarifier Loading Parameters
Table 3	Aerobic Digester/Holding Tank Criteria
Table 4	Summary of Double Ring Infiltrometer Tests
Table 5	Rapid Infiltration Basin Criteria

List of Figures

Figure 1	Site Map
Figure 2	Flow Diagram for FAST® Wastewater Treatment Plant

List of Appendices

Appendix A	Design Drawings
Appendix B	Geotechnical Report
Appendix C	FAST® Process Description and Calculations
Appendix D	FAST® Treatment Plant Performance Data
Appendix E	Technical Specifications

MPB/JEC/AS/ap
15183.doc

1.0 INTRODUCTION

The Spring Mountain Motorsports Ranch (SMMR) wastewater treatment plant (WWTP) is designed to serve the proposed SMMR development. These facilities are being financed by SMMR and will be executed by Double M Construction. Upon completion, the entire wastewater collection, treatment, and disposal facilities will be conveyed to Utilities, Inc. of Central Nevada (UICN), who will operate and maintain the system.

The project approach is to construct a pre-manufactured wastewater treatment facility in accordance with Nevada Division of Environmental Protection (NDEP) regulations and Water Technical Sheets (WTS <http://ndep.nv.gov/bwpc/wts-21.pdf>). The wastewater treatment facility will require an individual permit obtained through the NDEP Bureau of Water Pollution Control. For discharge to rapid infiltration basins (RIB's), the NDEP will require issuance of a Water Pollution Control (WPC) Permit.

1.1 Project Description

The project is located near Pahrump, Nevada, as shown on Figure 1. The WWTP is designed to serve the planned development that includes:

- Single family 80 residential lots along the east and north sides of the race track
- Commercial development along Highway 160 frontage
 - 20 acres – Phase 1
 - 42 acres – Phase 2
- Connection to existing track facilities (currently on well and septic)

The WWTP design includes the following main elements:

- Influent magnetic flow meter which measures the flow from the lift station force main at the discharge to the fine screen at the WWTP.
- Influent equalization basin (EQ basin)
- FAST® Package Treatment Plant using both suspended and fixed growth processes with anoxic denitrification
- Aerobic digester/sludge holding tank
- Rapid Infiltration Basins (RIBs)

Appendix A contains the preliminary design drawings for the WWTP. Figure 2 depicts the Flow Diagram for FAST® Wastewater Treatment Plant and illustrates the major process components and flow schematic.

2.0 DESIGN CRITERIA

2.1 Siting Criteria

The WWTP is located within the interior of the track facilities. The sewage lift station will be located in the southeast corner of the proposed project, which is at the low point of the development. The force main will convey the sewage to the plant site. The WWTP and RIB locations are shown on Figure 1. This figure also shows local topography and proposed single family lots. There are no water bodies within 2 miles of the SMRR. The WWTP is not located in a 100-year flood plain.

The site geotechnical report (Appendix B) percolation test results, recommended percolation rates and lab testing data to support the RIB sizing.

2.2 Influent Characterization

Table 1 provides information for the development of wastewater flow and influent characterization for the SMMR development.

TABLE 1: INFLUENT WASTEWATER CHARACTERIZATION

Table 1a: Average Daily Wastewater Flow

Criteria	Average Daily Flow (gpd)			
	Units	No. Units	Unit Flow	Total
Single Family Residential - Residential Equivalent (RE) ¹	gpd/RE	80	200	16000
Commercial - Currently Planned ²				
Retail A-F, Shops & C-Store	gpd/acre	5.37	1000	5,370
Restaurants, Fast Food, Coffee, & Doughnut Shops 8 seats/1000 sf = 288 Seats (60 gpd/seat) ³	Seat	288	60	17,280
Hotels - Number of Rooms – Approximately 97 @ 100gpd/room	Room	97	100	9,700
Theater 1250 seat @ 5 gal/seat	Seat	1,250	5.0	6,250
Existing Track Facility Water Use				
Potable Water Use - Based on fixture count	gal/day			11,509
SUBTOTAL				66,109
Commercial - Future Total Parcel Acreage	gpd/acre	42.6	1000	42,600
SUBTOTAL				108,709

Notes: ¹Flow criteria is LVVWD unless otherwise noted.

²Gallons per day Residential Equivalent (RE)

³Water & Sewage Works 1978 Reference R-159



Table 1b: Wastewater Loading

Criteria	Wastewater Loading	
	mg/L	Lbs/day
Biological Oxygen Demand Loading	250	137.8
Suspended Solids Loading	270	148.9
Total Kjeldahl Nitrogen – Organic Nitrogen + Ammonia ⁴	37.5	20.7
Biological Oxygen Demand Loading	250	226.7
Suspended Solids Loading	270	244.8
Total Kjeldahl Nitrogen – Organic Nitrogen + Ammonia ⁴	37.5	34.0

Notes: ⁴TKN: BOD ratio 0.1 to 0.2 from EPA Manual Nitrogen Control - Use 0.15

2.3 Effluent Limitations

The treatment plant must, at minimum, meet secondary treatment standards including

- 30 mg/l BOD₅
- 30 mg/l TSS
- total nitrogen ≤ 10 mg/L as N
- pH range of 6 to 9 S.U.

Effluent will be applied to ground waters using rapid infiltration basins (RIBs) and nitrification/denitrification will be provided to reduce nitrogen to ≤10 mg/l total nitrogen as N.

2.4 Odor Control

The WWTP will be located approximately 500 feet from the nearest residential lot. A vapor phase odor control facility will be provided at the sewage lift station. A biofilter will be installed to treat odors from the wet well. A liquid phase odor control system for the force main may also be installed at the lift station to control hydrogen sulfide gas formation in the force main and mitigate odors at the a mechanical screen if deemed necessary after a period of operation. The mechanical screen is enclosed and has a vent connection that could also facilitate the addition of a vapor phase odor control system at the screen, if needed. The EQ basin will be aerated and maintained in an aerobic condition; therefore, odors are not anticipated from this source. Sludge will be treated in an aerobic digester/holding tank. Sludge will be pumped from the tank and hauled to an existing offsite sludge processing facility. Odors are not anticipated from the aerobic digester/holding tank.

If additional odor control measures become necessary, a biofilter or activated carbon filter may be added to the screen vent. Further measures may include covering the EQ basin and providing a biofilter

to treat odors from this source. However, with the odor control measures at the lift station, additional odor control at the plant is not anticipated.

2.5 WWTP Design

2.5.1 Package Plant Data

The FAST® process description and calculations are included in Appendix C. This appendix contains a detailed description of the package plant process kinetic calculation for all unit processes including sizing of all tankage, retention times, loading parameters, and oxygen requirement, and oxygen transfer calculations.

Operating data from a similar WWTP located in West Bridgewater, Massachusetts, W. Center St. - Chili's Restaurant are contained in Appendix D FAST® Treatment Plant Performance Data. This is a smaller modular plant commonly used for commercial facilities. It differs from the larger plant proposed for SMMR because there is no clarifier in the small modular facility and waste sludge is allowed to accumulate in the reactor zone and is periodically removed from the tank. Plant performance shows very good results over the 20 months of data presented. Only one data point for high TSS is reported in January 2013. Testing is from single monthly grab samples so this elevated TSS value could be from the variability inherent in grab sampling or due to delayed pumping and removal of the accumulated sludge. Note that the test would not be a violation for typical 30 mg/l average and 45 mg/l maximum monthly criteria.

The Massachusetts facility is in a climate that is much colder in the winter and would present more difficult conditions for nitrification/denitrification; however, the total nitrogen values are very low as well as all other effluent values, indicating very consistent and excellent performance. Also, this is a high strength waste compared to "typical" residential wastewater.

2.5.2 Screening

A mechanical screen will be provided for the WWRF and a manual screen will be included in the bypass channel. The screen channels are enclosed and a vent connection is available for the connection of a vapor phase odor control system, if needed. The screenings will be washed within the screen system, dewatered, compacted, and conveyed to a receptacle for disposal in conventional trash collection and hauled to a suitable landfill.

An effluent sump is provided with a pump to convey water to the mechanical screen to flush organics from the screenings.

2.5.3 Equalization Basin

Screened sewage enters an aerated equalization basin (EQ Basin) where it is mixed and aerated with diffused air. Variable speed transfer pumps then deliver the sewage to the first anoxic zone where the incoming raw sewage is mixed with a nitrified recycle flow from the outlet end of the aerobic process tank.

2.5.4 Anoxic Reactors

Denitrification occurs in the anoxic tanks. The second tank provides better control for maintaining the anoxic condition for denitrification. The anoxic tanks are mixed with 2.2 HP mechanical mixers mounted on slide rails for removal and maintenance. The recycle rate is controlled to achieve the proper anoxic condition and to also achieve the desired level of nitrogen removal. The blowers are equipped with variable frequency drives to provide greater control of dissolved oxygen for nitrification/denitrification.

2.5.5 Grit Removal

There is no separate grit removal system; however, the screen channels will have a rock pocket and area for grit settling. The grit may be removed manually or with a septic tank pumper. The aerated EQ basin will likely collect any grit that is not collected at the screen inlet channel. The EQ basin should be cleaned periodically with a septic tank pumper.

2.5.6 Aeration Basin

Appendix C contains detailed oxygen demand calculations for the processes. A diffuser efficiency of 4% was used based on empirical information utilized by the FAST® manufacturer. An elevation correction of 1,000 feet was used to calculate oxygen transfer. This will be corrected for the 2,800 ft. elevation at the SMMR site and will be used to adjust the blower capacity as necessary. The main process aeration is supplied by a duty and standby blower. The EQ basin is served with one blower as is the aerobic digester/sludge holding tank and there is a standby blower that backs up these two duty blowers. The blower system capacity includes air for the various air lift pumps. Blowlers are equipped with VFD motors to provide control of the dissolved oxygen (DO) in the reactors. Also, a DO probe will be mounted in the FAST® aeration basin and a controller will be provided to vary blower speed to achieve an adjustable DO set point in the basin.

2.5.7 Settling

The sizing criteria for the secondary clarifier are provided in Table 2. The clarifier includes a system for scum removal and an air lift scum pump. Sludge pumping is accomplished with air lift pumps and the redundancy for the air supply from the blower is provided by the redundant blower.

Table 2 - Secondary Clarifier Loading Parameters

Criteria	Peak Hour	Average Q	Units
10 State Standards Criteria	1200	200 to 400	g/sf/day
Metcalf and Eddy 4th Edition (2003) ¹	1000 – 1600	200 to 400	g/sf/day
Phase 2 - Activated Sludge & Attached Growth Design Average Flow		108,800	gpd
Peak Hour is approximately 4 times Average Q: Use peak of 2 or less for the attenuated peak from the EQ Basin	2	n/a	Multiplier
Clarifier Hydraulic Load (Use Attenuated Peak)	217,600	108,800	gpd
Use M&E Criteria	1000	400	g/sf/day
Required Area	218	272	sf
Smith & Loveless Clarifier Area		288	sf
Package Plant Loading		378	g/sf/day

Notes: ¹ Metcalf and Eddy 4th Edition (2003)

² Smith & Loveless submittal is within established criteria.

2.6 Filtration

The discharge parameters will not require filtration.

2.7 Disinfection

The discharge parameters are not anticipated to require disinfection; however, a sodium hypochlorite facility may be added in the future, if needed, for process control of poorly settling filamentous or bulking mixed liquor suspended solids (MLSS).

2.8 Solids Management

Waste activated sludge (WAS) will be pumped to an aerobic digester/holding tank and the sludge hauled to an offsite facility operated by UICN that has capacity for sludge dewatering and disposal. The aerobic digester/holding tank has a capacity of 21,740 gallons. The aerobic digester/holding will be operated to settle the sludge and decant the liquid. Table 3 presents the anticipated sludge volume, thickened sludge concentration and volume of liquid sludge to be hauled at full design loading.

Table 3: Aerobic Digester/Holding Tank Criteria

Planned Development	No. Units	Units
Wastewater Flow - Planned Development	66,109	gpd
Biological Oxygen Demand (BOD) Removed	240	mg/L
BOD Loading	132.3	lbs/day
Total Suspended Solids (TSS)	270	mg/L
TSS Loading	148.9	lbs/day
Inert Solids (25% of influent TSS)	37.2	lbs/day
Volatile SS from Aerobic Digestion - 0.5 lbs VSS/lbs BOD	66.2	lbs/day
Daily Solids Production	103.4	lbs/day
Future Development¹		
Wastewater Flow - Plus Future Commercial	108,709	gpd
BOD Loading	217.6	lbs/day
Total Suspended Solids (TSS)	270	mg/L
TSS Loading	244.8	lbs/day
Inert Solids (25% of influent TSS)	61.2	lbs/day
Volatile SS from Aerobic Digestion - 0.5 lbs VSS/lbs BOD	108.8	lbs/day
Daily Solids Production	170.0	lbs/day
Digester/Holding Tank		
Additional VSS reduction in aerobic digester	40%	%
Daily Digested Sludge Production	126.5	lbs/day
Decanted Sludge Concentration	1.5%	%
Digester/Holding Tank 20 Day Volume	20,220	Gallons
Smith & Loveless Digester Tank Volume	21,700	Gallons

Notes: Use Future Development for Digester Criteria

2.9 Back-up Power

A standby generator will be provided and sized to operate all components at the WWTP. The plant connected load is 97.4 HP or 73 KW; however, the operating load is about 57.4 or 43 KW. If the generator will be sized to include power requirements for the second treatment module (needed for the Phase 2 development) the operating load would increase by 23 KW. Building electrical, such as ventilation, site lighting, and miscellaneous power will need to be added to the plant loads. In addition, an emergency overflow pond is provided if it is needed to take the system out of service for maintenance or cleaning.



2.10 Effluent Disposal

2.10.1 Infiltrometer Results

RIBs will be used for effluent disposal and design will conform to the provisions of WTS-3. Refer to the Geotechnical Report in Appendix B for the percolation and soils information for the intended RIB site. The Double Ring Infiltrometer Test results are summarized in Table 4. The results were variable with two inner ring tests below 2 in/hr. The average of all inner ring results is 9.88 in/hr. Another approach is to average the two tests at the 10 ft. depth and then average that value with the 5 ft. and the 15 ft. depths. This result is a slightly higher average value of 12.33 in/hr. The lower 9.88 in/hr. value will be used for design.

Table 4: Summary of Double Ring Infiltrometer Tests

Location and Depth	Soil Type	Inner Ring Infiltration Rate (in/hour)	Annular Ring Infiltration Rate (in/hour)
TP-01 at 5 ft	GW-GM	13.5	22.2
TP-01 at 10 ft	SM	0.5	1
TP-02 at 10 ft	GW-GM	4.5	1.2
TP-02 at 15 ft	GW-GM	21	22.1
Average Inner Ring		9.88	
Inner Ring Average of 5, 10, and 15 ft. Depths		12.33	

2.10.2 RIB Design Criteria

The design basis for the RIB cells is listed in Table 5. In accordance with the recommendation contained in "Land Treatment of Municipal Wastewater EPA 6+25/1-81-013 October 1981" the RIB area is based on 4% of the infiltrometer test value. The future design flow is 108,709 gpd and the treatment plant units will be sized for one half of the future flow or 54,350 gpd. One treatment plant unit will be constructed for the initial phase; however, the RIB cells will be oversized for the first phase and will provide two thirds of the future design flow. The design will be for two active RIB cells and a third cell will also be constructed to provide for drying and maintenance cycles. When the second treatment unit is installed and the flow reaches 72,000 gpd a fourth cell will be added to reach the future flow capacity for percolation. Due to the variable infiltration values, the construction plan is to excavate through the SM soils, if encountered, and do additional percolation testing to verify adequate percolation rates. Other areas on site have been identified for possible alternative RIB areas.

Table 5: Rapid Infiltration Basin Criteria

Item	Effluent Flow		Rate		RIB Area	# of Cells	Cell Area ²
	gpd	cf/hr	in/hr	ft/hr			
Average Inner Ring			9.88				
Application % of Infiltrometer Rate ¹			4%				
4% of Avg Cylinder Infiltrometer Rates			0.395	0.033			
Planned Development	66109	368.3			11187	2	5594
Plus Future Commercial	42600	237.3					
Total Future Development	108709	605.6			18397	3	6132

Notes: ¹ Land Treatment of Municipal Wastewater EPA 6+25/1-81-013 October 1981, Section 5.4.1, Page 5-12:
Annual hydraulic loading limited to 2 to 4% of the Cylinder Infiltrometer rate

² Surface Area with 3 ft. water depth in cells

Based on the above criteria, use the cell area for the total future development of 6,133 sf for each cell. Thus, the square dimensions for the cell water surface would be 75 ft. or any equivalent length/width dimensions.

3.0 DRAWINGS AND TECHNICAL SPECIFICATIONS

The Drawings for construction of the WWTP facilities are included in Appendix A. Technical Specifications have also been developed and are included in Appendix E.

4.0 WASTEWATER TREATMENT FACILITY OPERATIONS

The facility will be operated by Utilities Incorporated of Central Nevada (UNIC) and UNIC has established operating procedures for their facilities.

The manufacturer of the treatment facility (Smith and Loveless) will provide operation manuals for the operation of their system.

A manual will be submitted to NDEP prior to commissioning of the system to document operations and maintenance (O&M) requirements. The O&M Manual will include operating information obtained from equipment vendors and the UICN SOPs.

FIGURES

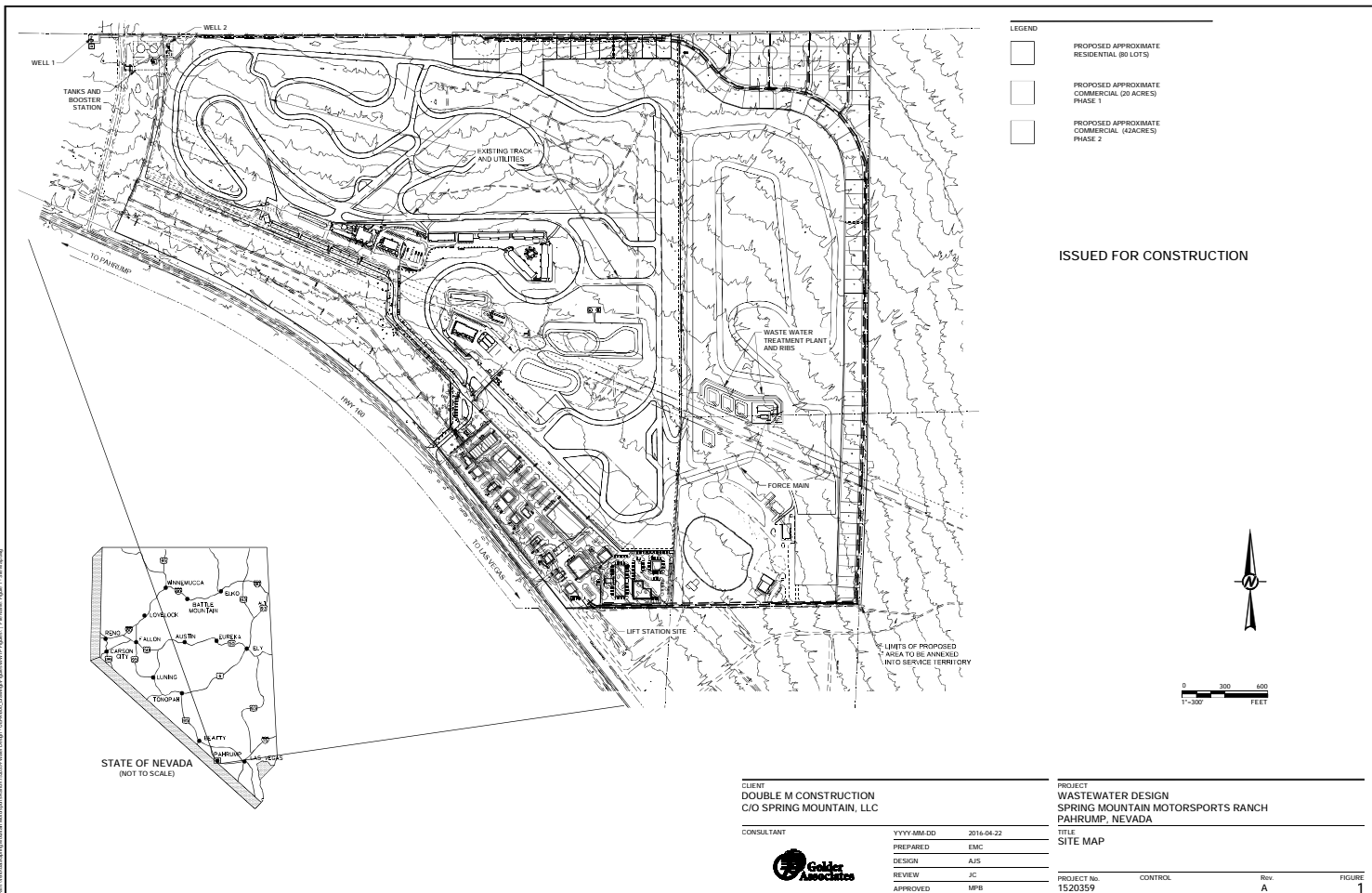

- LEGEND
- PROPOSED APPROXIMATE RESIDENTIAL (80 LOTS)
 - PROPOSED APPROXIMATE COMMERCIAL (20 ACRES) PHASE 1
 - PROPOSED APPROXIMATE COMMERCIAL (42 ACRES) PHASE 2

ISSUED FOR CONSTRUCTION

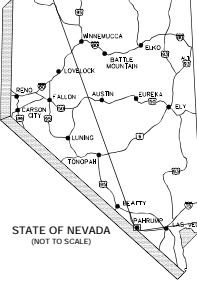

STATE OF NEVADA (NOT TO SCALE)

CLIENT
DOUBLE M CONSTRUCTION
 C/O SPRING MOUNTAIN, LLC

PROJECT
WASTEWATER DESIGN
 SPRING MOUNTAIN MOTORSPORTS RANCH
 PAHRUMP, NEVADA

CONSULTANT



YYYY-MM-DD	2016-04-22
PREPARED	EMC
DESIGN	AJS
REVIEW	JC
APPROVED	MPB

TITLE
SITE MAP

PROJECT No.	CONTROL	Rev.	FIGURE
1520359		A	1

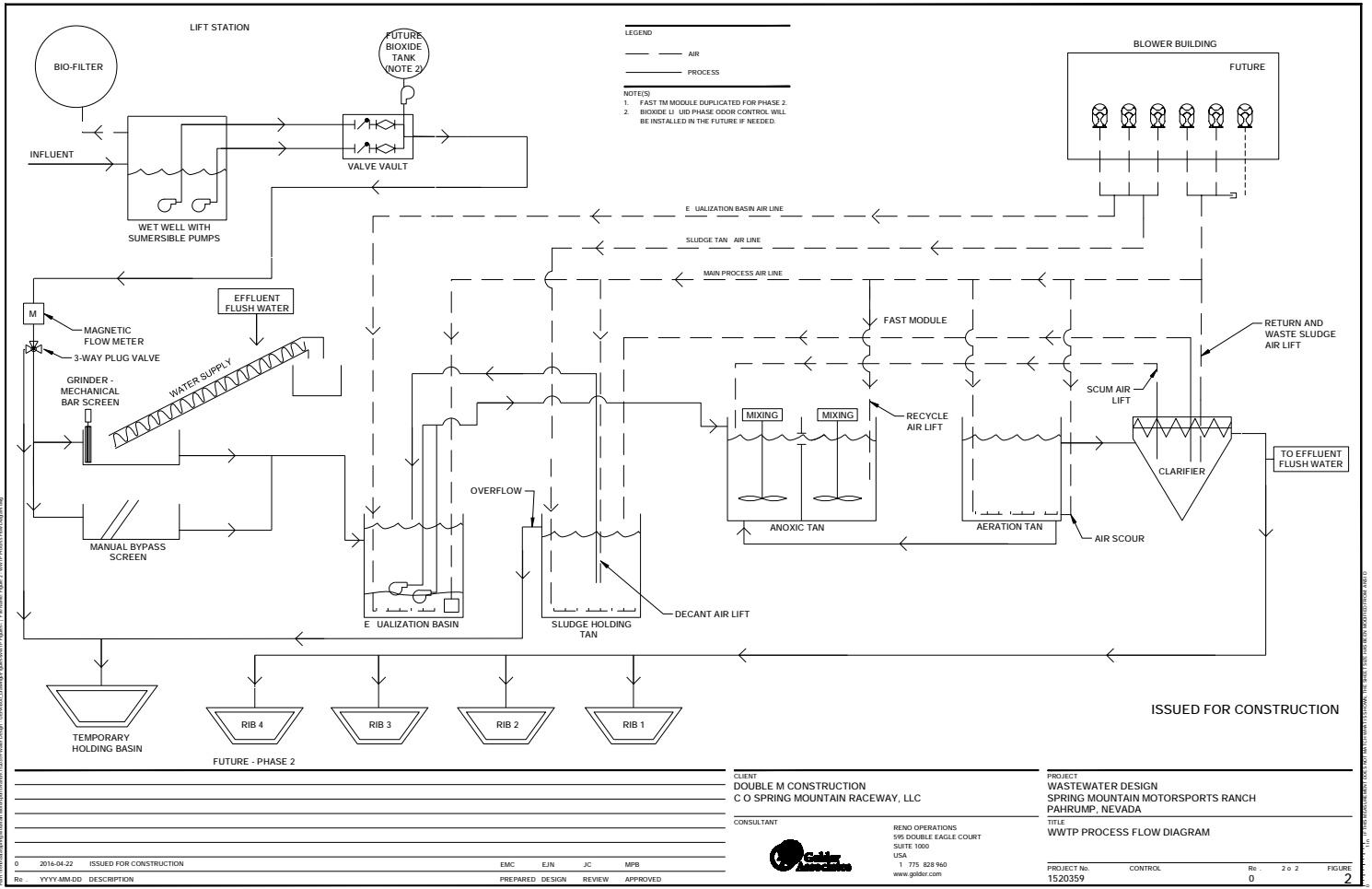

**APPENDIX A
DESIGN DRAWINGS**



Know what's below.
Call before you dig.

SPRING MOUNTAIN RACEWAY, LLC WASTEWATER TREATMENT SYSTEM FINAL DESIGN DOUBLE M CONSTRUCTION PAHRUMP, NEVADA

OPERATOR

UTILITIES INC. OF CENTRAL NV
1240 STATE ST #115
PAHRUMP, NV 89048
PHONE: 775-727-7488

OWNER / DEVELOPER

SPRING MOUNTAIN MOTORSPORTS RANCH
C/O DOUBLE M CONSTRUCTION
2770 S. CORTINA AVE.
PAHRUMP, NV 89048

BASIS OF BEARING

THE BASIS OF BEARING FOR THIS REAL PROPERTY DESCRIPTION IS THE NORTHEASTERLY LINE OF BLOCK 1 OF "CALVADA VALLEY UNIT No. 1" IN THE TOWN OF PAHRUMP, COUNTY OF RYE, STATE OF NEVADA, WHICH BEARS SOUTH 66°31'51" EAST, AS PER MAP RECORDED IN FILE MAP No. 20290 IN THE OFFICE OF THE COUNTY RECORDER OF SAID COUNTY.

BENCHMARK

USGS 5R80Z

FOUND UNITED STATES GEOLOGICAL SURVEY (U.S.G.S.) BRASS DISC ON ROD IN WHITE PVC PIPE, FLUSH WITH GROUND, STAMPED "5 R80 1981". LOCATED 2 METERS EAST OF A 4"x4" RIGHT-OF-WAY POST, 46 METERS SOUTH-SOUTHWEST OF STATE ROUTE 160 AT MILEPOST 3.25, APPROXIMATELY 5 KILOMETERS SOUTHWEST OF THE JUNCTION WITH STATE ROUTE 372, IN AN AREA OF HEAVILY PLOWED FURROWS IN GROUND.

NORTH AMERICAN VERTICAL DATUM 1988 (NAVD 88) AS PUBLISHED BY THE NEVADA DEPARTMENT OF TRANSPORTATION'S (NDOT) SURVEY MONUMENT LOCATION INFORMATION SERVICE (LOIS) FOR 5 R80 Z RETRIEVED 7/24/2007.

METERS = 835.500
U.S. SURVEY FEET = 2741.136

ABBREVIATIONS

DIA. (Ø) DIAMETER
DIMENSION RATIO
ELEV. ELEVATION
FT. FEET
HDPE HIGH DENSITY POLYETHYLENE
IN. INCHES
INV. INVERT

SHEET LIST TABLE	
T1	TITLE SHEET
T2	NOTES
G1	PROJECT MAP
C1	WWTP SITE GRADING PLAN
C2	WWTP SITE CROSS SECTION
C3	TREATMENT FACILITIES GRADING PLAN
C4	AERATION BLOWER YARD PIPING PLAN
D1	GENERAL DETAILS (1 OF 3)
D2	GENERAL DETAILS (2 OF 3)
D3	GENERAL DETAILS (3 OF 3)

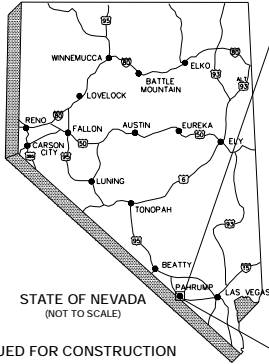

STATE OF NEVADA
(NOT TO SCALE)

ISSUED FOR CONSTRUCTION

REFERENCE-GOOGLE E RTH

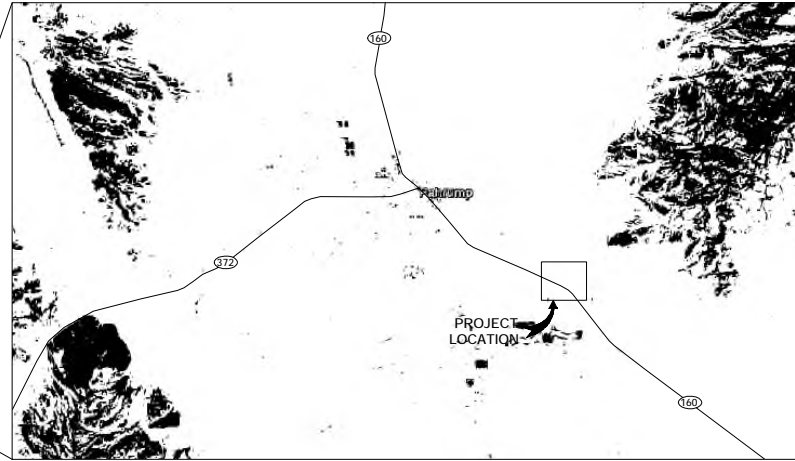

LOCATION MAP

CLIENT			
DOUBLE M CONSTRUCTION			
C/O SPRING MOUNTAIN RACEWAY, LLC			
CONSULTANT			
RENO OPERATIONS 595 DOUBLE EAGLE CT. #1000 RENO, NEVADA 89521 USA (1-1) (775) 828 1604 www.golder.com			
PROJECT			
WASTEWATER DESIGN			
SPRING MOUNTAIN MOTORSPORTS RANCH			
PAHRUMP, NEVADA			
TITLE SHEET			
PROJECT No.	CONTROL	Rev.	1 of 8 DRAWING
1520359		0	T1

GENERAL NOTES

- 1. CONTRACTOR SHALL PROVIDE ALL NECESSARY HORIZONTAL AND VERTICAL TRANSPORTATION... 2. LOCATIONS OF UNDERGROUND UTILITIES SHOWN ON THE DRAWINGS... 3. THE CONTRACTOR SHALL BE RESPONSIBLE FOR VERIFYING FIELD LOCATIONS... 4. THE CONTRACTOR SHALL TAKE ALL PRECAUTIONARY MEASURES NECESSARY TO PROTECT EXISTING IMPROVEMENTS... 5. ALL BRICKWORK AND TEMPORARY TRAFFIC CONTROL DEVICES OR METHODS... 6. THE CONTRACTOR SHALL BE RESPONSIBLE FOR THE VERTICAL ADJUSTMENT OF ALL EXISTING SANITARY WATER MAINS... 7. THE CONTRACTOR SHALL BE RESPONSIBLE FOR THE VERTICAL ADJUSTMENT OF ALL EXISTING SANITARY WATER MAINS... 8. STANDARD DETAILS AND SPECIFICATIONS FOR PUBLIC IMPROVEMENTS... 9. MANUAL ON ROADWAY DESIGN AND CONSTRUCTION STANDARDS FOR WATER DISTRIBUTION SYSTEMS... 10. THE CONTRACTOR SHALL BE RESPONSIBLE FOR THE VERTICAL ADJUSTMENT OF ALL TELEPHONE COMPANY MANHOLES... 11. ALL SITE GRADING WORK SHALL BE IN STRICT ACCORDANCE WITH THE SOILS REPORT FOR THE SITE... 12. ALL OFF-SITE IMPROVEMENT CONSTRUCTION SHALL CONFORM TO THE NVE COUNTY STANDARD DETAILS AND SPECIFICATIONS... 13. CURBS AND GUTTERS WITH A GRADE OF LESS THAN 4% OR ONE PERCENT SHALL BE CONSTRUCTED BY FORMING... 14. THE CONTRACTOR SHALL OBTAIN THE NECESSARY ENCROACHMENT PERMITS FOR CONSTRUCTION OUTSIDE THE PROJECT BOUNDARIES... 15. SIDEWALK RAMPS SHALL BE CONSTRUCTED AT EACH CHAIRLIFT OR AN INTERSECTION... 16. SLOPES STEEPER THAN 4:1 AND FINE GRADING MATERIALS THAT HAVE BEEN DISTURBED... 17. CONTRACTOR SHALL DETERMINE THE SOIL FOOTING OR BASEMENT EXCAVATION QUANTITIES... 18. THE CONTRACTOR SHALL OBTAIN ALL NECESSARY PERMITS FROM THE APPLICABLE UTILITY CITY... 19. THE CONTRACTOR SHALL BE RESPONSIBLE FOR PROVIDING EROSION CONTROL MEASURES... 20. CONTRACTOR SHALL BE RESPONSIBLE FOR PROVIDING EROSION CONTROL MEASURES... 21. THE CONSTRUCTION OF ALL SITES SHALL BE INSPECTED BY THE NVE COUNTY PUBLIC WORKS DEPARTMENT... 22. FINISHED GRADE OF A.C. PAVEMENT SHALL BE 12" ABOVE U.O. CURB AFTER COMPLETION... 23. CONTRACTOR SHALL SUBMIT A DUST CONTROL PLAN AND OBTAIN APPROVAL FROM THE NVE COUNTY PLANNING DEPARTMENT... 24. CONTRACTOR SHALL OBTAIN A SURFACE AREA DISTURBANCE CLASS PERMIT FROM THE STATE OF NEVADA... 25. STOCK PILES OF EARTH AND OTHER CONSTRUCTION RELATED MATERIAL MUST BE PROTECTED FROM BEING TRANSPORTED FROM THE SITE BY THE FORCES OF WIND OR WATER...

- 26. ALL WORK MUST COMPLY WITH THE FOLLOWING SPECIFICATIONS: 26.1 2006 INTERNATIONAL BUILDING CODE 26.2 2006 INTERNATIONAL RESIDENTIAL CODE 26.3 2006 INTERNATIONAL MECHANICAL CODE 26.4 2006 INTERNATIONAL FIRE CODE 26.5 2006 INTERNATIONAL ENERGY CONSERVATION CODE 26.6 2006 INTERNATIONAL MECHANICAL CODE 26.7 2006 NATIONAL ELECTRICAL CODE 26.8 NEVADA ADMINISTRATIVE CODE REGULATIONS 26.9 NVE COUNTY CODE 26.10 NVE COUNTY CODE 27. PUBLIC OR PRIVATE EASEMENTS FOR UTILITY AND STREETS FRONT PROPERTY SHALL BE OBTAINED PRIOR TO THE BEGINNING OF ANY WORK OR PERMITS... 28. SIDE PROPERTY LINES 29. REAR PROPERTY LINE 30. PERMITS NOTES

- 1. AN ENCROACHMENT PERMIT FROM THE NVE COUNTY PUBLIC WORKS DEPARTMENT WILL BE REQUIRED PRIOR TO THE BEGINNING OF ANY WORK OR PERMITS... 2. PUBLIC WORKS DEPARTMENT APPROVAL DOES NOT INCLUDE NECESSARY SEWER SYSTEM APPROVAL OR ESTIMATE OF QUANTITIES... 3. CONTRACTOR SHALL OBTAIN PERMIT TO CONSTRUCT RETAINING WALLS FROM PARHPUMP BUILDING DEPARTMENT... 4. AN APPROVED NVE COUNTY DUST CONTROL PLAN AND WHEN REQUIRED A STATE OF NEVADA SURFACE AREA DISTURBANCE CLASS PERMIT SHALL BE OBTAINED BY CONTRACTOR PRIOR TO MOBILIZATION OF EQUIPMENT TO THE PROJECT AREA.

REQUIREMENTS AND RESPONSIBILITIES

- 1. NO CONSTRUCTION SHALL COMMENCE PRIOR TO 6:00 AM EACH WORKING DAY... 2. IT IS THE RESPONSIBILITY OF THE CONTRACTOR TO FAMILIARIZE HIMSELF WITH THE JOB SITE AND THE LOCATION OF ALL UNDERGROUND UTILITIES... 3. THE CONTRACTOR SHALL NOTIFY UNDERGROUND SERVICE ALERT AT LEAST 48 HOURS PRIOR TO EXCAVATION... 4. ALL WORK SHALL BE DONE IN ACCORDANCE WITH THESE PLANS AND THE STANDARD DETAILS AND SPECIFICATIONS FOR PUBLIC IMPROVEMENTS... 5. IMMEDIATELY FOLLOWING REMOVAL OF EXISTING PAVEMENT OR DIRT CURB AND/OR GUTTERS... 6. PRESERVATION OR SUBSTITUTIONS OF ANY KIND AND ANY TELEPHONE OR POWER POLES... 7. PROPERTY OWNER SHALL MAINTAIN ALL ON-SITE DRYWELLS AND STORM DRAIN SYSTEMS... 8. APPROVAL OF PLANS BY NVE COUNTY OFFICIALS OR ITS AGENTS DOES NOT RELIEVE THE CONTRACTOR FROM RESPONSIBILITY FOR THE CORRECTION OF ERRORS... 9. THE CONTRACTOR SHALL SUBMIT ALL REVISIONS TO NVE COUNTY FOR APPROVAL.

GRADING NOTES

- 1. A PUBLIC WORKS DEPARTMENT ENCROACHMENT PERMIT IS REQUIRED FOR ANY CONSTRUCTION TEMPORARY OR PERMANENT ON COUNTY RIGHT OF WAY... 2. UPON COMPLETION OF GRADING, DEVELOPER SHALL SUBMIT A CERTIFICATE OF GRADING COMPLETION TO NVE COUNTY PUBLIC WORKS... 3. THE CONTRACTOR SHALL BE RESPONSIBLE FOR THE CORRECTION OF ERRORS... 4. THE CONTRACTOR SHALL SUBMIT A DUST CONTROL PLAN AND OBTAIN APPROVAL FROM THE NVE COUNTY PLANNING DEPARTMENT... 5. CONTRACTOR SHALL CONTACT ENGINEER A MINIMUM OF TWO WORKING DAYS PRIOR TO COMMENCEMENT OF GRADING OPERATIONS... 6. THE CONTRACTOR SHALL BE RESPONSIBLE FOR THE CORRECTION OF ERRORS... 7. ALL GRADING WORK SHOWN ON THIS PLAN SHALL BE DONE IN ACCORDANCE WITH THE INTERNATIONAL BUILDING CODE, OSHA, AND OTHER STATE LAWS AND LOCAL ORDINANCES... 8. ALL GRADING SHALL CONFORM TO THE RECOMMENDATIONS AND

- REQUIREMENTS OF THE PRELIMINARY SOILS REPORT DATED (DATED MARCH 21, 2008 BY NEVADA GEO-TECH INC. JOB REF. NO. 08-031) 9. CLEAR ALL AREAS OF FILL OR VEGETATION TO A DEPTH OF SIX (6) INCHES OR MORE... 10. ALL GRADING SHALL BE IN ACCORDANCE WITH THE INTERNATIONAL BUILDING CODE AND THE INTERNATIONAL MECHANICAL CODE... 11. ALL GRADING SHALL BE IN ACCORDANCE WITH THE INTERNATIONAL BUILDING CODE AND THE INTERNATIONAL MECHANICAL CODE... 12. ALL GRADING SHALL BE IN ACCORDANCE WITH THE INTERNATIONAL BUILDING CODE AND THE INTERNATIONAL MECHANICAL CODE... 13. ALL GRADING SHALL BE IN ACCORDANCE WITH THE INTERNATIONAL BUILDING CODE AND THE INTERNATIONAL MECHANICAL CODE... 14. ALL GRADING SHALL BE IN ACCORDANCE WITH THE INTERNATIONAL BUILDING CODE AND THE INTERNATIONAL MECHANICAL CODE... 15. ALL GRADING SHALL BE IN ACCORDANCE WITH THE INTERNATIONAL BUILDING CODE AND THE INTERNATIONAL MECHANICAL CODE... 16. ALL GRADING SHALL BE IN ACCORDANCE WITH THE INTERNATIONAL BUILDING CODE AND THE INTERNATIONAL MECHANICAL CODE... 17. ALL GRADING SHALL BE IN ACCORDANCE WITH THE INTERNATIONAL BUILDING CODE AND THE INTERNATIONAL MECHANICAL CODE... 18. ALL GRADING SHALL BE IN ACCORDANCE WITH THE INTERNATIONAL BUILDING CODE AND THE INTERNATIONAL MECHANICAL CODE... 19. ALL GRADING SHALL BE IN ACCORDANCE WITH THE INTERNATIONAL BUILDING CODE AND THE INTERNATIONAL MECHANICAL CODE... 20. ALL GRADING SHALL BE IN ACCORDANCE WITH THE INTERNATIONAL BUILDING CODE AND THE INTERNATIONAL MECHANICAL CODE...

- 1. ALL WATER LINES 4" OR GREATER TO BE CL. 250, C900 PVC. ALL WATER LINES SMALLER THAN 4" TO BE SCH. 40, 150 LB. GALV. STEEL... 2. ALL SANITARY SEWER LINES AND LATERALS TO BE 8" OR 6" PVC. ALL FORCE MAIN SANITARY SEWER LINES TO BE C900 PURPLE PIPE... 3. CONTRACTOR TO FIELD VERIFY LOCATION OF ALL UTILITY STUDIES PRIOR TO CONSTRUCTION... 4. ALL 4" SEWER LATERALS TO BE LAD A NOT LESS THAN 2%... 5. WATER MAINS SHALL BE DISINFECTED AS PER AWWA C651 PRIOR TO FIRST USE... 6. WATER MAINS SHALL BE PRESSURE TESTED PER LATEST EDITION OF STANDARD SPECIFICATIONS FOR PUBLIC WORKS CONSTRUCTION... 7. IDENTIFICATION WIRE IDENTIFICATION WIRE SHALL BE INSTALLED WITH ALL POLYVINYL CHLORIDE (PVC) PIPE... 8. IDENTIFICATION WIRE SHALL BE INSTALLED WITH ALL POLYVINYL CHLORIDE (PVC) PIPE... 9. IDENTIFICATION WIRE SHALL BE INSTALLED WITH ALL POLYVINYL CHLORIDE (PVC) PIPE... 10. IDENTIFICATION WIRE SHALL BE INSTALLED WITH ALL POLYVINYL CHLORIDE (PVC) PIPE... 11. IDENTIFICATION WIRE SHALL BE INSTALLED WITH ALL POLYVINYL CHLORIDE (PVC) PIPE... 12. IDENTIFICATION WIRE SHALL BE INSTALLED WITH ALL POLYVINYL CHLORIDE (PVC) PIPE... 13. IDENTIFICATION WIRE SHALL BE INSTALLED WITH ALL POLYVINYL CHLORIDE (PVC) PIPE... 14. IDENTIFICATION WIRE SHALL BE INSTALLED WITH ALL POLYVINYL CHLORIDE (PVC) PIPE... 15. IDENTIFICATION WIRE SHALL BE INSTALLED WITH ALL POLYVINYL CHLORIDE (PVC) PIPE... 16. IDENTIFICATION WIRE SHALL BE INSTALLED WITH ALL POLYVINYL CHLORIDE (PVC) PIPE... 17. IDENTIFICATION WIRE SHALL BE INSTALLED WITH ALL POLYVINYL CHLORIDE (PVC) PIPE... 18. IDENTIFICATION WIRE SHALL BE INSTALLED WITH ALL POLYVINYL CHLORIDE (PVC) PIPE... 19. IDENTIFICATION WIRE SHALL BE INSTALLED WITH ALL POLYVINYL CHLORIDE (PVC) PIPE... 20. IDENTIFICATION WIRE SHALL BE INSTALLED WITH ALL POLYVINYL CHLORIDE (PVC) PIPE...

UTILITIES INC. OF CENTRAL NEVADA GENERAL NOTES

- 1. THE TECHNICAL SPECIFICATIONS DEVELOPED BY GOLDEN ASSOCIATES INC. AND PRESENTED IN THE DESIGN REPORT SHALL TAKE PRECEDENCE OVER MORE SPECIFICATIONS SHOWN ON THIS DRAWING... 2. TRENCH SHORING AND SHEETING IN THE EVENT THE WORK WILL EXHAUST EXCAVATIONS WHICH WILL BE FIVE (5) FEET OR DEEPER AND INFO WHICH PERSONNEL WILL BE REQUIRED TO DESIGN PRIOR TO COMMENCING SUCH CONSTRUCTION... 3. THE CONTRACTOR SHALL OBTAIN A PERMIT FROM THE NEVADA DEPARTMENT OF INDUSTRIAL SAFETY... 4. DUST CONTROL THE CONTRACTOR SHALL SUBMIT TO UTILITIES, INC. FOUR (4) COPIES OF ANY SHOP AND ERECTOR DRAWINGS INCLUDING THE PLANS AND SPECIFICATIONS... 5. GATE VALVES ALL GATE VALVES MUST EQUAL OR EXCEED THE REQUIREMENTS OF THE LATEST REVISION OF AWWA C506 OR AWWA C509 STANDARDS FOR GATE VALVES AND RESULTANT SEATED GATE VALVES AND SHALL BE WELLER OR APPROVED EQUAL... 6. BLOW OFF VALVE ASSEMBLIES THE CONTRACTOR SHALL INSTALL BLOW OFF ASSEMBLIES AS DETAILED ON THE PLANS... 7. FIRE HYDRANT ASSEMBLIES FIRE HYDRANT ASSEMBLIES SHALL INCLUDE THE CONNECTION TO THE MAIN AND SHALL CONSIST OF FIRE HYDRANT AND APPURTENANCES IN ACCORDANCE WITH THESE SPECIFICATIONS AND AS SHOWN ON THE STANDARD DRAWINGS... 8. VALVE BOXES AND COVERS VALVE BOXES FOR BURIED VALVES SHALL BE CAST IRON TWO-THEFEET 24 INCHES 24 INCHES DEPTH... 9. FLANGE INSTALLATION TECHNIQUES FLANGE INSTALLATION TECHNIQUES SHALL BE INSTALLED AS SHOWN ON APPROVED PLANS OR AS DIRECTED BY UTILITIES, INC. AND SHALL BE CALIPKO, INC. RUBBER-CURED GASKETS AND APPROVED EQUAL... 10. POLYVINYL CHLORIDE (PVC) PIPE AND JOINTS SHALL BE DESIGNED AND MANUFACTURED IN ACCORDANCE WITH ANSIAWWA STANDARD C900, LATEST REVISION, AND APPENDIX A OF SAID STANDARD... 11. PIPE MARKING SHALL BE IN ACCORDANCE WITH ANSIAWWA STANDARD C900 INCLUDING THE SEAL MARK OF THE TESTING AGENCY WHICH VERIFIED THE SUFFICIENCY OF THE PIPE MATERIAL FOR PORTABLE WATER SERVICE... 12. FITTINGS SHALL SEE DUCTILE IRON AND SHALL CONFORM TO THE LATEST REVISION OF EITHER ANSI AWWA STANDARD C151 OR ANSI AWWA C151/A151 CLASS 350 ALL FITTINGS AND ACCESSORIES SHALL BE REVISION AND APPENDIX A OF SAID STANDARD... 13. JOINTS SHALL BE RESTRAINED JOINTS IN ACCORDANCE WITH THE LATEST REVISION OF ANSIAWWA STANDARD C114/111... 14. ALL FITTINGS JOINTS SHALL BE FULLY RESTRAINED IN ANY ONE DIRECTION... 15. JOINTS AND BENDS CHANGES IN ALIGNMENT AND GRADE MAY BE DEFLECTING THE PIPE UNITS AT JOINTS AS PROVIDED HEREIN AND PIPE UNITS SHORTER THAN STANDARD LENGTHS MAY BE REQUIRED... 16. MORE THAN HALF (1/2) OF THE MANUFACTURER'S RECOMMENDATION PIPE WEIGHT FACTOR SHOULD BE USED... 17. IDENTIFICATION WIRE IDENTIFICATION WIRE SHALL BE INSTALLED WITH ALL POLYVINYL CHLORIDE (PVC) PIPE... 18. IDENTIFICATION WIRE SHALL BE INSTALLED WITH ALL POLYVINYL CHLORIDE (PVC) PIPE... 19. IDENTIFICATION WIRE SHALL BE INSTALLED WITH ALL POLYVINYL CHLORIDE (PVC) PIPE... 20. IDENTIFICATION WIRE SHALL BE INSTALLED WITH ALL POLYVINYL CHLORIDE (PVC) PIPE...

UTILITIES INC. OF CENTRAL NEVADA VALVE NOTES

- 1. GATE VALVES ALL GATE VALVES MUST EQUAL OR EXCEED THE REQUIREMENTS OF THE LATEST REVISION OF AWWA C506 OR AWWA C509 STANDARDS FOR GATE VALVES AND RESULTANT SEATED GATE VALVES AND SHALL BE WELLER OR APPROVED EQUAL... 2. BLOW OFF VALVE ASSEMBLIES THE CONTRACTOR SHALL INSTALL BLOW OFF ASSEMBLIES AS DETAILED ON THE PLANS... 3. FIRE HYDRANT ASSEMBLIES FIRE HYDRANT ASSEMBLIES SHALL INCLUDE THE CONNECTION TO THE MAIN AND SHALL CONSIST OF FIRE HYDRANT AND APPURTENANCES IN ACCORDANCE WITH THESE SPECIFICATIONS AND AS SHOWN ON THE STANDARD DRAWINGS... 4. VALVE BOXES AND COVERS VALVE BOXES FOR BURIED VALVES SHALL BE CAST IRON TWO-THEFEET 24 INCHES 24 INCHES DEPTH... 5. FLANGE INSTALLATION TECHNIQUES FLANGE INSTALLATION TECHNIQUES SHALL BE INSTALLED AS SHOWN ON APPROVED PLANS OR AS DIRECTED BY UTILITIES, INC. AND SHALL BE CALIPKO, INC. RUBBER-CURED GASKETS AND APPROVED EQUAL... 6. POLYVINYL CHLORIDE (PVC) PIPE AND JOINTS SHALL BE DESIGNED AND MANUFACTURED IN ACCORDANCE WITH ANSIAWWA STANDARD C900, LATEST REVISION, AND APPENDIX A OF SAID STANDARD... 7. PIPE MARKING SHALL BE IN ACCORDANCE WITH ANSIAWWA STANDARD C900 INCLUDING THE SEAL MARK OF THE TESTING AGENCY WHICH VERIFIED THE SUFFICIENCY OF THE PIPE MATERIAL FOR PORTABLE WATER SERVICE... 8. FITTINGS SHALL SEE DUCTILE IRON AND SHALL CONFORM TO THE LATEST REVISION OF EITHER ANSI AWWA STANDARD C151 OR ANSI AWWA C151/A151 CLASS 350 ALL FITTINGS AND ACCESSORIES SHALL BE REVISION AND APPENDIX A OF SAID STANDARD... 9. JOINTS SHALL BE RESTRAINED JOINTS IN ACCORDANCE WITH THE LATEST REVISION OF ANSIAWWA STANDARD C114/111... 10. ALL FITTINGS JOINTS SHALL BE FULLY RESTRAINED IN ANY ONE DIRECTION... 11. JOINTS AND BENDS CHANGES IN ALIGNMENT AND GRADE MAY BE DEFLECTING THE PIPE UNITS AT JOINTS AS PROVIDED HEREIN AND PIPE UNITS SHORTER THAN STANDARD LENGTHS MAY BE REQUIRED... 12. MORE THAN HALF (1/2) OF THE MANUFACTURER'S RECOMMENDATION PIPE WEIGHT FACTOR SHOULD BE USED... 13. IDENTIFICATION WIRE IDENTIFICATION WIRE SHALL BE INSTALLED WITH ALL POLYVINYL CHLORIDE (PVC) PIPE... 14. IDENTIFICATION WIRE SHALL BE INSTALLED WITH ALL POLYVINYL CHLORIDE (PVC) PIPE... 15. IDENTIFICATION WIRE SHALL BE INSTALLED WITH ALL POLYVINYL CHLORIDE (PVC) PIPE... 16. IDENTIFICATION WIRE SHALL BE INSTALLED WITH ALL POLYVINYL CHLORIDE (PVC) PIPE... 17. IDENTIFICATION WIRE SHALL BE INSTALLED WITH ALL POLYVINYL CHLORIDE (PVC) PIPE... 18. IDENTIFICATION WIRE SHALL BE INSTALLED WITH ALL POLYVINYL CHLORIDE (PVC) PIPE... 19. IDENTIFICATION WIRE SHALL BE INSTALLED WITH ALL POLYVINYL CHLORIDE (PVC) PIPE... 20. IDENTIFICATION WIRE SHALL BE INSTALLED WITH ALL POLYVINYL CHLORIDE (PVC) PIPE...

- TO TWELVE (12) INCHES ABOVE THE TOP OF THE PIPE SHALL BE IMPORTED 49R FILL SAND HAVING A MINIMUM OF EQUIVALENT OF SAFE... 2. BLOW OFF VALVE ASSEMBLIES THE CONTRACTOR SHALL INSTALL BLOW OFF ASSEMBLIES AS DETAILED ON THE PLANS... 3. FIRE HYDRANT ASSEMBLIES FIRE HYDRANT ASSEMBLIES SHALL INCLUDE THE CONNECTION TO THE MAIN AND SHALL CONSIST OF FIRE HYDRANT AND APPURTENANCES IN ACCORDANCE WITH THESE SPECIFICATIONS AND AS SHOWN ON THE STANDARD DRAWINGS... 4. VALVE BOXES AND COVERS VALVE BOXES FOR BURIED VALVES SHALL BE CAST IRON TWO-THEFEET 24 INCHES 24 INCHES DEPTH... 5. FLANGE INSTALLATION TECHNIQUES FLANGE INSTALLATION TECHNIQUES SHALL BE INSTALLED AS SHOWN ON APPROVED PLANS OR AS DIRECTED BY UTILITIES, INC. AND SHALL BE CALIPKO, INC. RUBBER-CURED GASKETS AND APPROVED EQUAL... 6. POLYVINYL CHLORIDE (PVC) PIPE AND JOINTS SHALL BE DESIGNED AND MANUFACTURED IN ACCORDANCE WITH ANSIAWWA STANDARD C900, LATEST REVISION, AND APPENDIX A OF SAID STANDARD... 7. PIPE MARKING SHALL BE IN ACCORDANCE WITH ANSIAWWA STANDARD C900 INCLUDING THE SEAL MARK OF THE TESTING AGENCY WHICH VERIFIED THE SUFFICIENCY OF THE PIPE MATERIAL FOR PORTABLE WATER SERVICE... 8. FITTINGS SHALL SEE DUCTILE IRON AND SHALL CONFORM TO THE LATEST REVISION OF EITHER ANSI AWWA STANDARD C151 OR ANSI AWWA C151/A151 CLASS 350 ALL FITTINGS AND ACCESSORIES SHALL BE REVISION AND APPENDIX A OF SAID STANDARD... 9. JOINTS SHALL BE RESTRAINED JOINTS IN ACCORDANCE WITH THE LATEST REVISION OF ANSIAWWA STANDARD C114/111... 10. ALL FITTINGS JOINTS SHALL BE FULLY RESTRAINED IN ANY ONE DIRECTION... 11. JOINTS AND BENDS CHANGES IN ALIGNMENT AND GRADE MAY BE DEFLECTING THE PIPE UNITS AT JOINTS AS PROVIDED HEREIN AND PIPE UNITS SHORTER THAN STANDARD LENGTHS MAY BE REQUIRED... 12. MORE THAN HALF (1/2) OF THE MANUFACTURER'S RECOMMENDATION PIPE WEIGHT FACTOR SHOULD BE USED... 13. IDENTIFICATION WIRE IDENTIFICATION WIRE SHALL BE INSTALLED WITH ALL POLYVINYL CHLORIDE (PVC) PIPE... 14. IDENTIFICATION WIRE SHALL BE INSTALLED WITH ALL POLYVINYL CHLORIDE (PVC) PIPE... 15. IDENTIFICATION WIRE SHALL BE INSTALLED WITH ALL POLYVINYL CHLORIDE (PVC) PIPE... 16. IDENTIFICATION WIRE SHALL BE INSTALLED WITH ALL POLYVINYL CHLORIDE (PVC) PIPE... 17. IDENTIFICATION WIRE SHALL BE INSTALLED WITH ALL POLYVINYL CHLORIDE (PVC) PIPE... 18. IDENTIFICATION WIRE SHALL BE INSTALLED WITH ALL POLYVINYL CHLORIDE (PVC) PIPE... 19. IDENTIFICATION WIRE SHALL BE INSTALLED WITH ALL POLYVINYL CHLORIDE (PVC) PIPE... 20. IDENTIFICATION WIRE SHALL BE INSTALLED WITH ALL POLYVINYL CHLORIDE (PVC) PIPE...

- 1. POLYVINYL CHLORIDE (PVC) PIPE AND JOINTS SHALL BE DESIGNED AND MANUFACTURED IN ACCORDANCE WITH ANSIAWWA STANDARD C900, LATEST REVISION, AND APPENDIX A OF SAID STANDARD... 2. PIPE MARKING SHALL BE IN ACCORDANCE WITH ANSIAWWA STANDARD C900 INCLUDING THE SEAL MARK OF THE TESTING AGENCY WHICH VERIFIED THE SUFFICIENCY OF THE PIPE MATERIAL FOR PORTABLE WATER SERVICE... 3. FITTINGS SHALL SEE DUCTILE IRON AND SHALL CONFORM TO THE LATEST REVISION OF EITHER ANSI AWWA STANDARD C151 OR ANSI AWWA C151/A151 CLASS 350 ALL FITTINGS AND ACCESSORIES SHALL BE REVISION AND APPENDIX A OF SAID STANDARD... 4. ALL FITTINGS JOINTS SHALL BE FULLY RESTRAINED IN ANY ONE DIRECTION... 5. JOINTS AND BENDS CHANGES IN ALIGNMENT AND GRADE MAY BE DEFLECTING THE PIPE UNITS AT JOINTS AS PROVIDED HEREIN AND PIPE UNITS SHORTER THAN STANDARD LENGTHS MAY BE REQUIRED... 6. MORE THAN HALF (1/2) OF THE MANUFACTURER'S RECOMMENDATION PIPE WEIGHT FACTOR SHOULD BE USED... 7. IDENTIFICATION WIRE IDENTIFICATION WIRE SHALL BE INSTALLED WITH ALL POLYVINYL CHLORIDE (PVC) PIPE... 8. IDENTIFICATION WIRE SHALL BE INSTALLED WITH ALL POLYVINYL CHLORIDE (PVC) PIPE... 9. IDENTIFICATION WIRE SHALL BE INSTALLED WITH ALL POLYVINYL CHLORIDE (PVC) PIPE... 10. IDENTIFICATION WIRE SHALL BE INSTALLED WITH ALL POLYVINYL CHLORIDE (PVC) PIPE... 11. IDENTIFICATION WIRE SHALL BE INSTALLED WITH ALL POLYVINYL CHLORIDE (PVC) PIPE... 12. IDENTIFICATION WIRE SHALL BE INSTALLED WITH ALL POLYVINYL CHLORIDE (PVC) PIPE... 13. IDENTIFICATION WIRE SHALL BE INSTALLED WITH ALL POLYVINYL CHLORIDE (PVC) PIPE... 14. IDENTIFICATION WIRE SHALL BE INSTALLED WITH ALL POLYVINYL CHLORIDE (PVC) PIPE... 15. IDENTIFICATION WIRE SHALL BE INSTALLED WITH ALL POLYVINYL CHLORIDE (PVC) PIPE... 16. IDENTIFICATION WIRE SHALL BE INSTALLED WITH ALL POLYVINYL CHLORIDE (PVC) PIPE... 17. IDENTIFICATION WIRE SHALL BE INSTALLED WITH ALL POLYVINYL CHLORIDE (PVC) PIPE... 18. IDENTIFICATION WIRE SHALL BE INSTALLED WITH ALL POLYVINYL CHLORIDE (PVC) PIPE... 19. IDENTIFICATION WIRE SHALL BE INSTALLED WITH ALL POLYVINYL CHLORIDE (PVC) PIPE... 20. IDENTIFICATION WIRE SHALL BE INSTALLED WITH ALL POLYVINYL CHLORIDE (PVC) PIPE...

- 1. ANCHOR AND THRUST BLOCKS SHALL BE INSTALLED AT FITTING AND VALVES AND WHERE DIRECTED BY UTILITIES, INC. IN ACCORDANCE WITH DETAILS SHOWN ON STANDARD DRAWING W-4 IN THE UTILITIES, INC. STANDARDS, SPECIFICATIONS AND DRAWINGS... 2. HYDROSTATIC TESTS AFTER THE PIPE BACKFILL HAS BEEN COMPLETED AND ACCEPTED THE PIPE SHALL BE SUBJECT TO A HYDROSTATIC PRESSURE TEST AS HEREINAFTER SPECIFIED... 3. IDENTIFICATION OF WATER MAINS AND SERVICES ALL WATER MAIN, WATER SERVICES, ATTACHED APPURTENANCES, AND TEMPORARY CONNECTIONS, IF ANY, SHALL BE IDENTIFIED IN ACCORDANCE WITH AWWA C501 AND THE FOLLOWING REQUIREMENTS... 4. TREATMENT OF WATER SHALL BE RETAINED IN THE SYSTEM FOR A PERIOD OF TWENTY-FOUR (24) HOURS MINIMUM AND SHALL PRODUCE NOT LESS THAN TWENTY-FIVE (25) PPM IN ALL SECTIONS BEING DISINFECTED AT THE END OF THE TWENTY-FOUR (24) HOUR PERIOD... 5. CHLORINE TABLETS SHALL BE ATTACHED WITH PERMITS NO. 1 RECOMMENDATION SHALL BE DONE USING CHLORINE GAS/NET SOLUTION... 6. EXCAVATION OF PIPELINE TRENCH A. PLACING OF PIPE, ZONE BEDDING AND BACKFILL MATERIAL, ALL IN ONE ZONE BACKFILL, TO A DEPTH OF SIX (6) INCHES BELOW THE BOTTOM OF THE PIPE...

UTILITIES INC. OF CENTRAL NEVADA PIPELINE INSTALLATION NOTES

- 1. ANCHOR AND THRUST BLOCKS SHALL BE INSTALLED AT FITTING AND VALVES AND WHERE DIRECTED BY UTILITIES, INC. IN ACCORDANCE WITH DETAILS SHOWN ON STANDARD DRAWING W-4 IN THE UTILITIES, INC. STANDARDS, SPECIFICATIONS AND DRAWINGS... 2. HYDROSTATIC TESTS AFTER THE PIPE BACKFILL HAS BEEN COMPLETED AND ACCEPTED THE PIPE SHALL BE SUBJECT TO A HYDROSTATIC PRESSURE TEST AS HEREINAFTER SPECIFIED... 3. IDENTIFICATION OF WATER MAINS AND SERVICES ALL WATER MAIN, WATER SERVICES, ATTACHED APPURTENANCES, AND TEMPORARY CONNECTIONS, IF ANY, SHALL BE IDENTIFIED IN ACCORDANCE WITH AWWA C501 AND THE FOLLOWING REQUIREMENTS... 4. TREATMENT OF WATER SHALL BE RETAINED IN THE SYSTEM FOR A PERIOD OF TWENTY-FOUR (24) HOURS MINIMUM AND SHALL PRODUCE NOT LESS THAN TWENTY-FIVE (25) PPM IN ALL SECTIONS BEING DISINFECTED AT THE END OF THE TWENTY-FOUR (24) HOUR PERIOD... 5. CHLORINE TABLETS SHALL BE ATTACHED WITH PERMITS NO. 1 RECOMMENDATION SHALL BE DONE USING CHLORINE GAS/NET SOLUTION... 6. EXCAVATION OF PIPELINE TRENCH A. PLACING OF PIPE, ZONE BEDDING AND BACKFILL MATERIAL, ALL IN ONE ZONE BACKFILL, TO A DEPTH OF SIX (6) INCHES BELOW THE BOTTOM OF THE PIPE...

- TO TWELVE (12) INCHES ABOVE THE TOP OF THE PIPE SHALL BE IMPORTED 49R FILL SAND HAVING A MINIMUM OF EQUIVALENT OF SAFE... 2. BLOW OFF VALVE ASSEMBLIES THE CONTRACTOR SHALL INSTALL BLOW OFF ASSEMBLIES AS DETAILED ON THE PLANS... 3. FIRE HYDRANT ASSEMBLIES FIRE HYDRANT ASSEMBLIES SHALL INCLUDE THE CONNECTION TO THE MAIN AND SHALL CONSIST OF FIRE HYDRANT AND APPURTENANCES IN ACCORDANCE WITH THESE SPECIFICATIONS AND AS SHOWN ON THE STANDARD DRAWINGS... 4. VALVE BOXES AND COVERS VALVE BOXES FOR BURIED VALVES SHALL BE CAST IRON TWO-THEFEET 24 INCHES 24 INCHES DEPTH... 5. FLANGE INSTALLATION TECHNIQUES FLANGE INSTALLATION TECHNIQUES SHALL BE INSTALLED AS SHOWN ON APPROVED PLANS OR AS DIRECTED BY UTILITIES, INC. AND SHALL BE CALIPKO, INC. RUBBER-CURED GASKETS AND APPROVED EQUAL... 6. POLYVINYL CHLORIDE (PVC) PIPE AND JOINTS SHALL BE DESIGNED AND MANUFACTURED IN ACCORDANCE WITH ANSIAWWA STANDARD C900, LATEST REVISION, AND APPENDIX A OF SAID STANDARD... 7. PIPE MARKING SHALL BE IN ACCORDANCE WITH ANSIAWWA STANDARD C900 INCLUDING THE SEAL MARK OF THE TESTING AGENCY WHICH VERIFIED THE SUFFICIENCY OF THE PIPE MATERIAL FOR PORTABLE WATER SERVICE... 8. FITTINGS SHALL SEE DUCTILE IRON AND SHALL CONFORM TO THE LATEST REVISION OF EITHER ANSI AWWA STANDARD C151 OR ANSI AWWA C151/A151 CLASS 350 ALL FITTINGS AND ACCESSORIES SHALL BE REVISION AND APPENDIX A OF SAID STANDARD... 9. JOINTS SHALL BE RESTRAINED JOINTS IN ACCORDANCE WITH THE LATEST REVISION OF ANSIAWWA STANDARD C114/111... 10. ALL FITTINGS JOINTS SHALL BE FULLY RESTRAINED IN ANY ONE DIRECTION... 11. JOINTS AND BENDS CHANGES IN ALIGNMENT AND GRADE MAY BE DEFLECTING THE PIPE UNITS AT JOINTS AS PROVIDED HEREIN AND PIPE UNITS SHORTER THAN STANDARD LENGTHS MAY BE REQUIRED... 12. MORE THAN HALF (1/2) OF THE MANUFACTURER'S RECOMMENDATION PIPE WEIGHT FACTOR SHOULD BE USED... 13. IDENTIFICATION WIRE IDENTIFICATION WIRE SHALL BE INSTALLED WITH ALL POLYVINYL CHLORIDE (PVC) PIPE... 14. IDENTIFICATION WIRE SHALL BE INSTALLED WITH ALL POLYVINYL CHLORIDE (PVC) PIPE... 15. IDENTIFICATION WIRE SHALL BE INSTALLED WITH ALL POLYVINYL CHLORIDE (PVC) PIPE... 16. IDENTIFICATION WIRE SHALL BE INSTALLED WITH ALL POLYVINYL CHLORIDE (PVC) PIPE... 17. IDENTIFICATION WIRE SHALL BE INSTALLED WITH ALL POLYVINYL CHLORIDE (PVC) PIPE... 18. IDENTIFICATION WIRE SHALL BE INSTALLED WITH ALL POLYVINYL CHLORIDE (PVC) PIPE... 19. IDENTIFICATION WIRE SHALL BE INSTALLED WITH ALL POLYVINYL CHLORIDE (PVC) PIPE... 20. IDENTIFICATION WIRE SHALL BE INSTALLED WITH ALL POLYVINYL CHLORIDE (PVC) PIPE...

- 1. POLYVINYL CHLORIDE (PVC) PIPE AND JOINTS SHALL BE DESIGNED AND MANUFACTURED IN ACCORDANCE WITH ANSIAWWA STANDARD C900, LATEST REVISION, AND APPENDIX A OF SAID STANDARD... 2. PIPE MARKING SHALL BE IN ACCORDANCE WITH ANSIAWWA STANDARD C900 INCLUDING THE SEAL MARK OF THE TESTING AGENCY WHICH VERIFIED THE SUFFICIENCY OF THE PIPE MATERIAL FOR PORTABLE WATER SERVICE... 3. FITTINGS SHALL SEE DUCTILE IRON AND SHALL CONFORM TO THE LATEST REVISION OF EITHER ANSI AWWA STANDARD C151 OR ANSI AWWA C151/A151 CLASS 350 ALL FITTINGS AND ACCESSORIES SHALL BE REVISION AND APPENDIX A OF SAID STANDARD... 4. ALL FITTINGS JOINTS SHALL BE FULLY RESTRAINED IN ANY ONE DIRECTION... 5. JOINTS AND BENDS CHANGES IN ALIGNMENT AND GRADE MAY BE DEFLECTING THE PIPE UNITS AT JOINTS AS PROVIDED HEREIN AND PIPE UNITS SHORTER THAN STANDARD LENGTHS MAY BE REQUIRED... 6. MORE THAN HALF (1/2) OF THE MANUFACTURER'S RECOMMENDATION PIPE WEIGHT FACTOR SHOULD BE USED... 7. IDENTIFICATION WIRE IDENTIFICATION WIRE SHALL BE INSTALLED WITH ALL POLYVINYL CHLORIDE (PVC) PIPE... 8. IDENTIFICATION WIRE SHALL BE INSTALLED WITH ALL POLYVINYL CHLORIDE (PVC) PIPE... 9. IDENTIFICATION WIRE SHALL BE INSTALLED WITH ALL POLYVINYL CHLORIDE (PVC) PIPE... 10. IDENTIFICATION WIRE SHALL BE INSTALLED WITH ALL POLYVINYL CHLORIDE (PVC) PIPE... 11. IDENTIFICATION WIRE SHALL BE INSTALLED WITH ALL POLYVINYL CHLORIDE (PVC) PIPE... 12. IDENTIFICATION WIRE SHALL BE INSTALLED WITH ALL POLYVINYL CHLORIDE (PVC) PIPE... 13. IDENTIFICATION WIRE SHALL BE INSTALLED WITH ALL POLYVINYL CHLORIDE (PVC) PIPE... 14. IDENTIFICATION WIRE SHALL BE INSTALLED WITH ALL POLYVINYL CHLORIDE (PVC) PIPE... 15. IDENTIFICATION WIRE SHALL BE INSTALLED WITH ALL POLYVINYL CHLORIDE (PVC) PIPE... 16. IDENTIFICATION WIRE SHALL BE INSTALLED WITH ALL POLYVINYL CHLORIDE (PVC) PIPE... 17. IDENTIFICATION WIRE SHALL BE INSTALLED WITH ALL POLYVINYL CHLORIDE (PVC) PIPE... 18. IDENTIFICATION WIRE SHALL BE INSTALLED WITH ALL POLYVINYL CHLORIDE (PVC) PIPE... 19. IDENTIFICATION WIRE SHALL BE INSTALLED WITH ALL POLYVINYL CHLORIDE (PVC) PIPE... 20. IDENTIFICATION WIRE SHALL BE INSTALLED WITH ALL POLYVINYL CHLORIDE (PVC) PIPE...

- 1. ANCHOR AND THRUST BLOCKS SHALL BE INSTALLED AT FITTING AND VALVES AND WHERE DIRECTED BY UTILITIES, INC. IN ACCORDANCE WITH DETAILS SHOWN ON STANDARD DRAWING W-4 IN THE UTILITIES, INC. STANDARDS, SPECIFICATIONS AND DRAWINGS... 2. HYDROSTATIC TESTS AFTER THE PIPE BACKFILL HAS BEEN COMPLETED AND ACCEPTED THE PIPE SHALL BE SUBJECT TO A HYDROSTATIC PRESSURE TEST AS HEREINAFTER SPECIFIED... 3. IDENTIFICATION OF WATER MAINS AND SERVICES ALL WATER MAIN, WATER SERVICES, ATTACHED APPURTENANCES, AND TEMPORARY CONNECTIONS, IF ANY, SHALL BE IDENTIFIED IN ACCORDANCE WITH AWWA C501 AND THE FOLLOWING REQUIREMENTS... 4. TREATMENT OF WATER SHALL BE RETAINED IN THE SYSTEM FOR A PERIOD OF TWENTY-FOUR (24) HOURS MINIMUM AND SHALL PRODUCE NOT LESS THAN TWENTY-FIVE (25) PPM IN ALL SECTIONS BEING DISINFECTED AT THE END OF THE TWENTY-FOUR (24) HOUR PERIOD... 5. CHLORINE TABLETS SHALL BE ATTACHED WITH PERMITS NO. 1 RECOMMENDATION SHALL BE DONE USING CHLORINE GAS/NET SOLUTION... 6. EXCAVATION OF PIPELINE TRENCH A. PLACING OF PIPE, ZONE BEDDING AND BACKFILL MATERIAL, ALL IN ONE ZONE BACKFILL, TO A DEPTH OF SIX (6) INCHES BELOW THE BOTTOM OF THE PIPE...

UTILITIES INC. OF CENTRAL NEVADA PIPELINE INSTALLATION NOTES

- 1. ANCHOR AND THRUST BLOCKS SHALL BE INSTALLED AT FITTING AND VALVES AND WHERE DIRECTED BY UTILITIES, INC. IN ACCORDANCE WITH DETAILS SHOWN ON STANDARD DRAWING W-4 IN THE UTILITIES, INC. STANDARDS, SPECIFICATIONS AND DRAWINGS... 2. HYDROSTATIC TESTS AFTER THE PIPE BACKFILL HAS BEEN COMPLETED AND ACCEPTED THE PIPE SHALL BE SUBJECT TO A HYDROSTATIC PRESSURE TEST AS HEREINAFTER SPECIFIED... 3. IDENTIFICATION OF WATER MAINS AND SERVICES ALL WATER MAIN, WATER SERVICES, ATTACHED APPURTENANCES, AND TEMPORARY CONNECTIONS, IF ANY, SHALL BE IDENTIFIED IN ACCORDANCE WITH AWWA C501 AND THE FOLLOWING REQUIREMENTS... 4. TREATMENT OF WATER SHALL BE RETAINED IN THE SYSTEM FOR A PERIOD OF TWENTY-FOUR (24) HOURS MINIMUM AND SHALL PRODUCE NOT LESS THAN TWENTY-FIVE (25) PPM IN ALL SECTIONS BEING DISINFECTED AT THE END OF THE TWENTY-FOUR (24) HOUR PERIOD... 5. CHLORINE TABLETS SHALL BE ATTACHED WITH PERMITS NO. 1 RECOMMENDATION SHALL BE DONE USING CHLORINE GAS/NET SOLUTION... 6. EXCAVATION OF PIPELINE TRENCH A. PLACING OF PIPE, ZONE BEDDING AND BACKFILL MATERIAL, ALL IN ONE ZONE BACKFILL, TO A DEPTH OF SIX (6) INCHES BELOW THE BOTTOM OF THE PIPE...

ISSUED FOR CONSTRUCTION

- PROJECT: WASTEWATER DESIGN SPRING MOUNTAIN MOTORSPORTS RANCH PARHPUMP, NEVADA TITLE: NOTES

0	2016-05-02	ISSUED FOR CONSTRUCTION	EMC	AJS	JC	MBI			
Rev	YYYY-MM-DD	DESCRIPTION	PREPARED	DESIGN	REVIEW	APPROVED			



DATE PLOTTED: 2016/05/02 10:05:11 AM

DRAWING: T2



- LEGEND**
- EXISTING GROUND
 - SECTION LINES
 - EXISTING ROW
 - EXISTING ROADS
 - PROPOSED ROADS
 - WATER SYSTEM BY: GOLDER ASSOCIATES WATER SYSTEM DESIGN
 - WATER SYSTEM BY: IMPULSE ENGINEERING RESIDENTIAL IMPROVEMENT PLANS
 - FORCE MAIN BY: GOLDER ASSOCIATES LIFT STATION AND FORCE MAIN DESIGN
 - GRAVITY SEWER SYSTEM BY: IMPULSE ENGINEERING RESIDENTIAL IMPROVEMENT PLANS
 - RESIDENTIAL LOT NUMBER



ISSUED FOR CONSTRUCTION



CLIENT DOUBLE M CONSTRUCTION C/O SPRING MOUNTAIN RACEWAY, LLC				PROJECT WASTEWATER DESIGN SPRING MOUNTAIN MOTORSPORTS RANCH PAHRUMP, NEVADA			
CONSULTANT  RENO OPERATIONS 595 DOUBLE EAGLE CT. #1000 RENO, NEVADA 89521 USA (+1) (775) 838-1604 www.golder.com				TITLE PROJECT MAP			
0 2016-05-02 ISSUED FOR CONSTRUCTION Rev. YYY-MM-DD DESCRIPTION	EMC PREPARED	AJS DESIGN	JC REVIEW	MPB APPROVED	PROJECT No. 1520359	CONTROL 0	Rev. 2 of 8 DRAWING G1

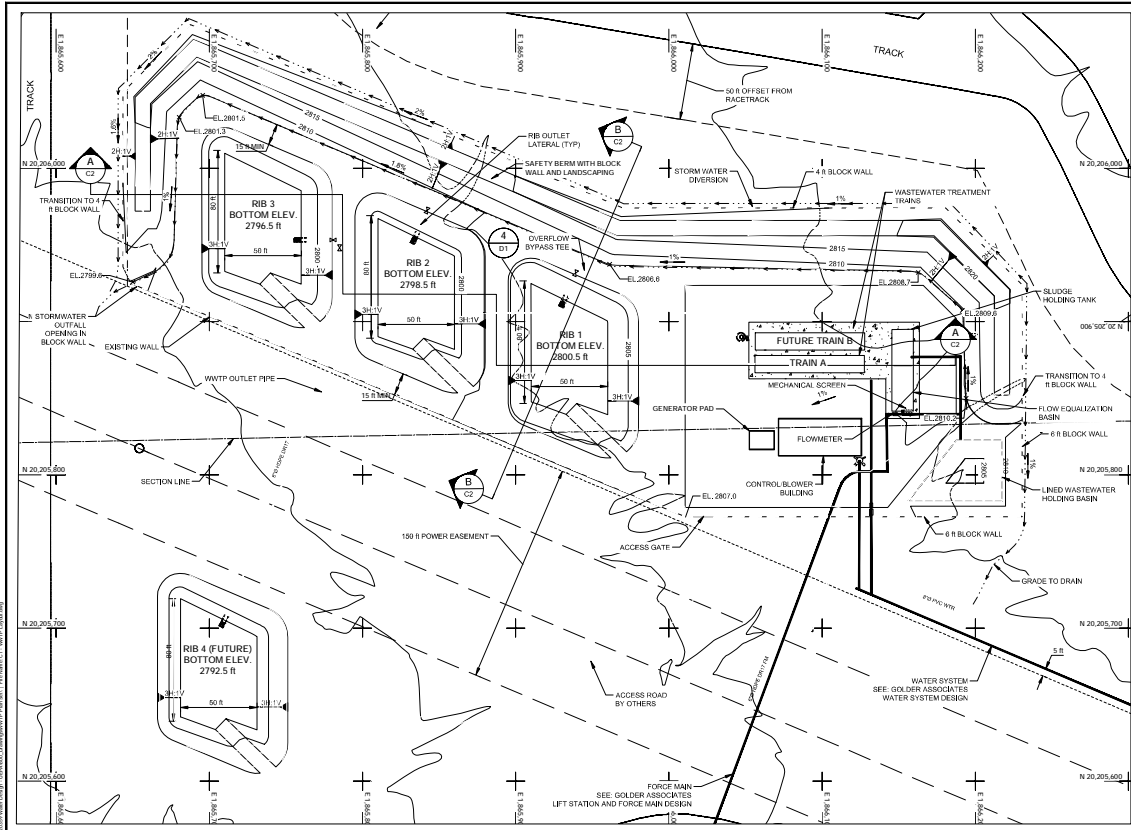

LEGEND

- EXISTING ROAD
- - - EXISTING POWER LINE
- - - 50 FT OFFSET FROM TRACK
- - - SECTION LINE
- - - EXISTING GROUND (1 FT CONTOUR INTERVALS)
- - - PROPOSED GRADING (1 FT CONTOUR INTERVALS)
- ▬ 2811.0 CONCRETE FINISH GRADE SURFACE
- ▬ ASPHALT FINISH GRADE SURFACE
- ▬ 48" PVC 802 WATER SYSTEM SEE: GOLDR ASSOCIATES WATER SYSTEM DESIGN
- ▬ 18" HDPE 10811M FORCE MAIN SEE: GOLDR ASSOCIATES LIFT STATION AND FORCE MAIN DESIGN
- ▬ 18" HDPE 10811M WWTP OUTLET PIPE
- ⊥ GATE VALVE
- - - STORM WATER DIVERSION FLOW LINE
- ⊕ FIRE HYDRANT
- ⊕ FINISH GRADE

ISSUED FOR CONSTRUCTION

0 30 60
1"=30' FEET

PROFESSIONAL SEAL
MICHAEL P. BIDART
CIVIL ENGINEER
No. 10224
5/1/16

CLIENT DOUBLE M CONSTRUCTION C/O SPRING MOUNTAIN RACEWAY, LLC		PROJECT WASTEWATER DESIGN SPRING MOUNTAIN MOTORSPORTS RANCH PAHRUMP, NEVADA	
CONSULTANT 		RENO OPERATIONS 595 DOUBLE EAGLE CT #1000 RENO, NEVADA 89521 USA (+1) (775) 828-1604 www.goldr.com	
0 2016-05-02 ISSUED FOR CONSTRUCTION	EMC AJJ JC MPB	PROJECT No. 1520359	CONTROL 0
Rev. YYYV-MM-DD DESCRIPTION	PREPARED DESIGN REVIEW APPROVED	Rev. 3 of 4	DRAWING C1

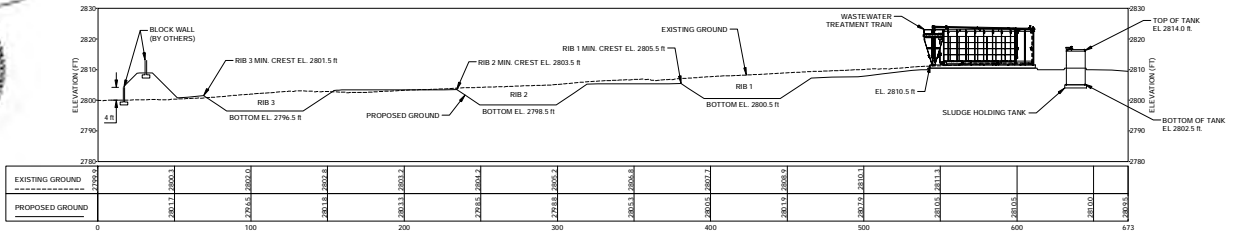

HORIZ. SCALE A
VERT. SCALE B
A SITE SECTION

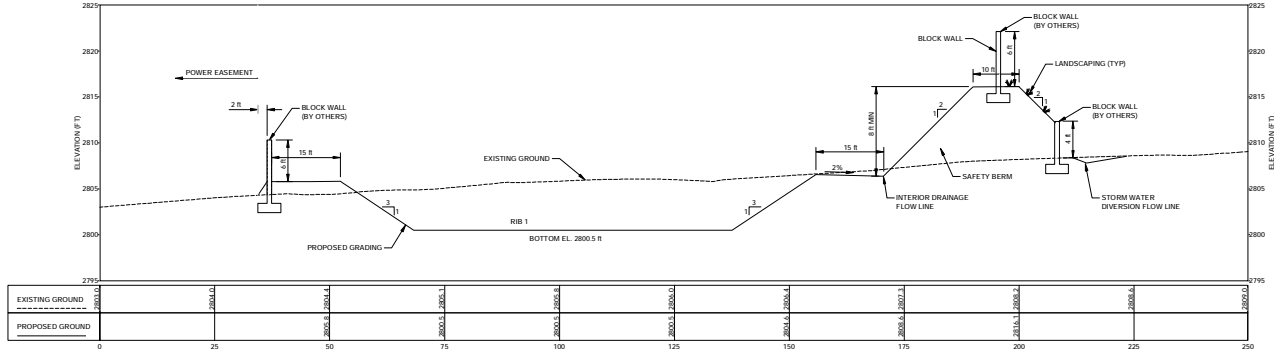

HORIZ. SCALE C
VERT. SCALE D
B SITE SECTION

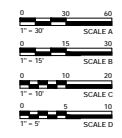

ISSUED FOR CONSTRUCTION

0	2016-05-02	ISSUED FOR CONSTRUCTION	EMC	AJS	JC	MPB
Rev	YYYY-MM-DD	DESCRIPTION	PREPARED	DESIGN	REVIEW	APPROVED

CLIENT DOUBLE M CONSTRUCTION C/O SPRING MOUNTAIN RACEWAY, LLC	PROJECT WASTEWATER DESIGN SPRING MOUNTAIN MOTORSPORTS RANCH PAHRUMP, NEVADA
CONSULTANT RENO OPERATIONS 595 DOUBLE EAGLE CT #1000 RENO, NEVADA 89521 USA (775) 838-1604 www.goblor.com	TITLE WWTP SITE CROSS SECTION
PROJECT No. 1520359	CONTROL
Rev. 0	4 of 8
DRAWING	C2

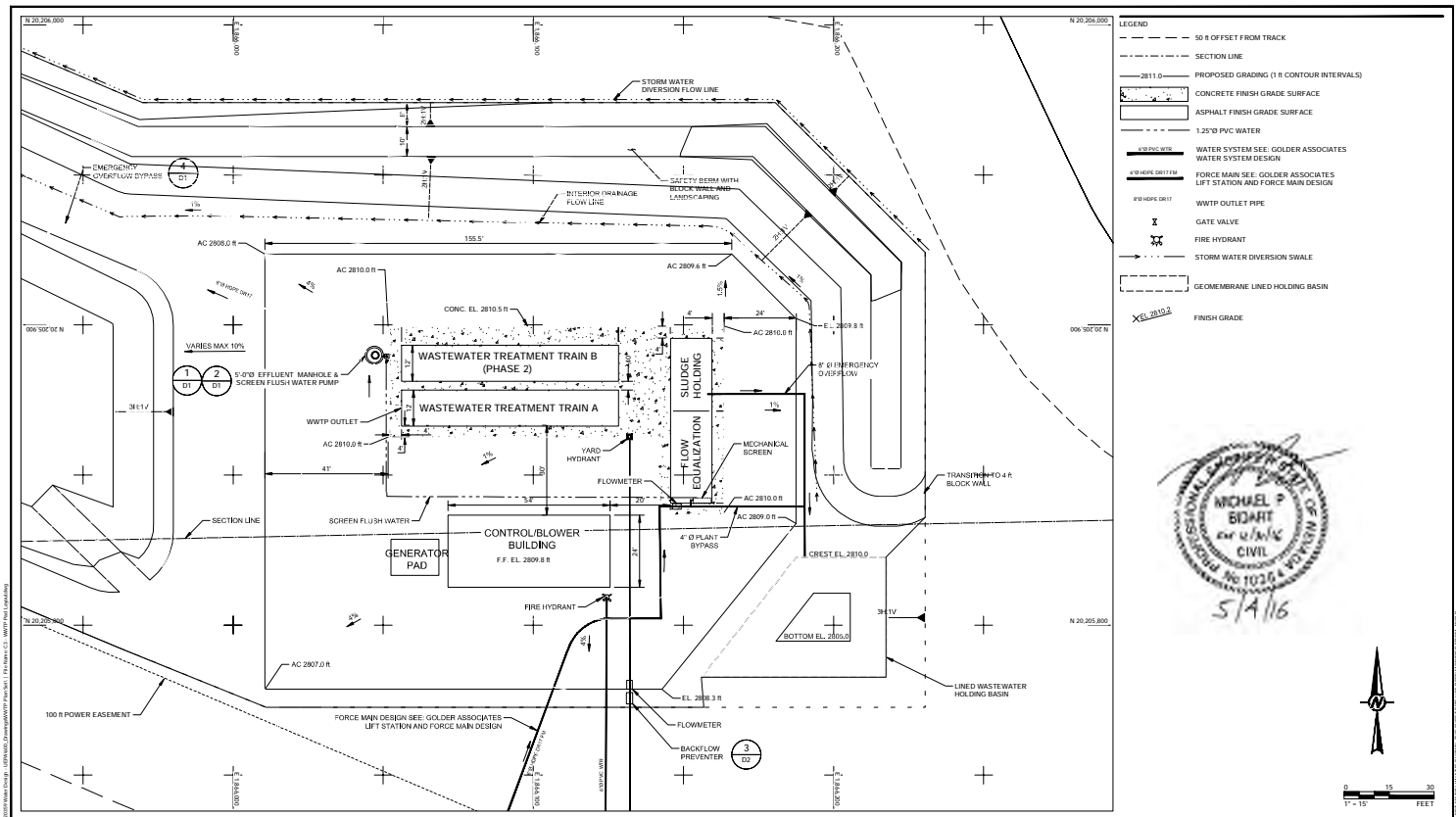

- LEGEND**
- 50 R OFFSET FROM TRACK
 - SECTION LINE
 - 2811.0 PROPOSED GRADING (1 FT CONTOUR INTERVALS)
 - CONCRETE FINISH GRADE SURFACE
 - ASPHALT FINISH GRADE SURFACE
 - 1.25" Ø PVC WATER
 - 1/2" Ø PVC WATER
 - 1/2" Ø PVC WTR FORCE MAIN SEE: GOLDR ASSOCIATES WATER SYSTEM DESIGN
 - 1/2" Ø PVC 150# RCP FORCE MAIN SEE: GOLDR ASSOCIATES LIFT STATION AND FORCE MAIN DESIGN
 - 1/2" Ø PVC 150# WTP OUTLET PIPE
 - X GATE VALVE
 - FW FIRE HYDRANT
 - STORM WATER DIVERSION SWALE
 - GEOMEMBRANE LINED HOLDING BASIN
 - XEL 2810.0 FINISH GRADE



<p>CLIENT DOUBLE M CONSTRUCTION C/O SPRING MOUNTAIN RACEWAY, LLC</p> <p>CONSULTANT GOLD ASSOCIATES</p> <p>RENO OPERATIONS 595 DOUBLE EAGLE CT #1000 RENO, NEVADA 89521 USA (715) 838-1604 www.goldr.com</p>	<p>PROJECT WASTEWATER DESIGN SPRING MOUNTAIN MOTORSPORTS RANCH PAHRUMP, NEVADA</p> <p>TITLE TREATMENT FACILITIES GRADING PLAN</p> <p>PROJECT No. 1520359 CONTROL Rev. 0 5 of 8 DRAWING C3</p>
---	---

<p>0 2016-05-02 ISSUED FOR CONSTRUCTION</p>	<p>EMC AJJ JC MPB</p>	<p>PREPARED DESIGN REVIEW APPROVED</p>
---	-----------------------	--

ISSUED FOR CONSTRUCTION

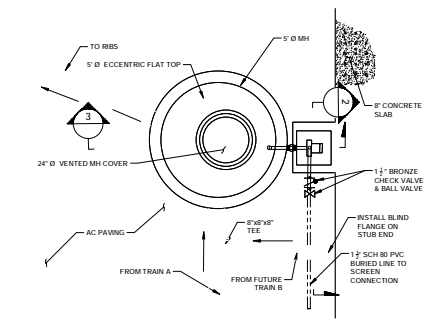

SCALE A 1 EFFLUENT FLUSH WATER PUMP MANHOLE PLAN VIEW

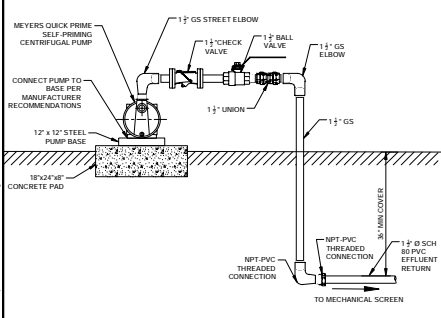

NTS 2 EFFLUENT FLUSH WATER PUMP SECTION

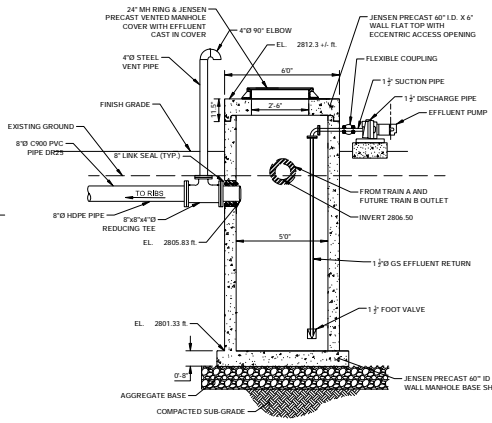

NTS 3 EFFLUENT FLUSH WATER PUMP MANHOLE SECTION

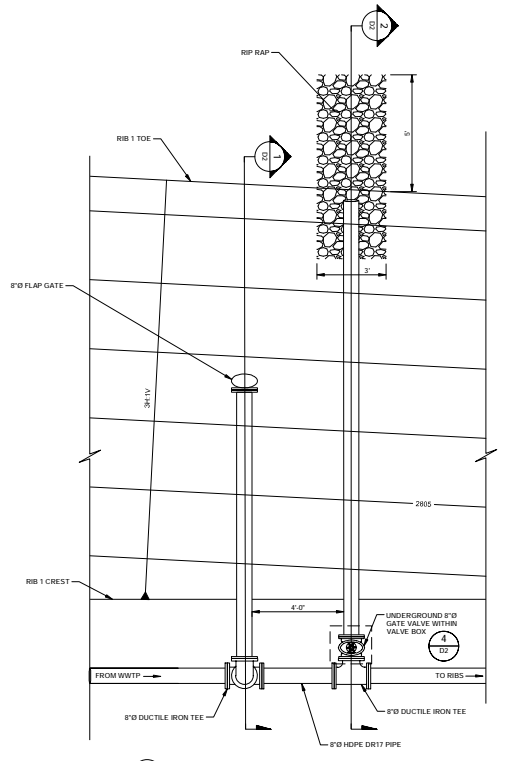

SCALE A 4 EMERGENCY OVERFLOW BYPASS AND RIB 1 DISCHARGE PLAN

CLIENT DOUBLE M CONSTRUCTION C/O SPRING MOUNTAIN RACEWAY, LLC	PROJECT WASTEWATER DESIGN SPRING MOUNTAIN MOTORSPORTS RANCH PAHRUMP, NEVADA
CONSULTANT RENO OPERATIONS 595 DOUBLE EAGLE CT #1000 RENO, NEVADA 89521 USA (775) 838-1604 www.gbdor.com	TITLE GENERAL DETAILS (1 OF 3)
PROJECT No. 1520359	CONTROL
Rev. 0	6 of 8 DRAWING

0	2016-05-02	ISSUED FOR CONSTRUCTION	EMC	AJS	JC	MPB
Rev.	YYYY-MM-DD	DESCRIPTION	PREPARED	DESIGN	REVIEW	APPROVED



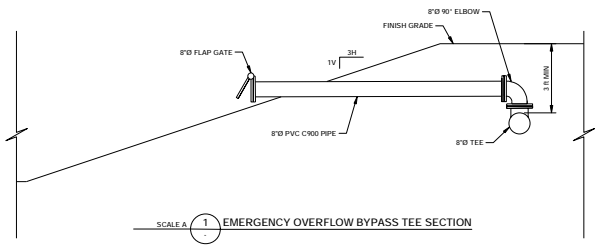

SCALE A 1 EMERGENCY OVERFLOW BYPASS TEE SECTION

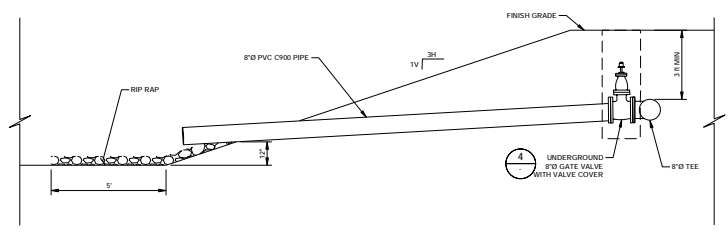

SCALE A 2 TYPICAL RIB OUTLET LATERAL SECTION

ISSUED FOR CONSTRUCTION

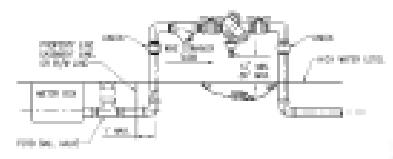

NTS 3 BACKFLOW PREVENTOR DETAIL
UTILITIES INC. OF CENTRAL NEVADA
WATER STANDARD DRAWINGS
DRAWING W-15

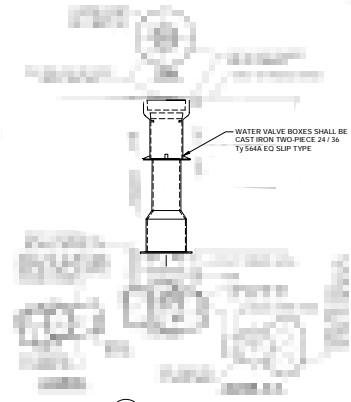

NTS 4 VALVE COVER DETAIL
UTILITIES INC. OF CENTRAL NEVADA
WATER STANDARD DRAWINGS
DRAWING W-10



0		2016-05-02	ISSUED FOR CONSTRUCTION	EMC	AJS	JC	MPB
Rev	YYYY-MM-DD	DESCRIPTION	PREPARED	DESIGN	REVIEW	APPROVED	

CLIENT DOUBLE M CONSTRUCTION 610 SPRING MOUNTAIN RACEWAY, LLC	PROJECT WASTEWATER DESIGN SPRING MOUNTAIN MOTORSPORTS RANCH PAHRUMP, NEVADA
CONSULTANT 	RENO OPERATIONS 595 DOUBLE EAGLE CT. #1000 RENO, NEVADA 89521 USA (1-775) 828-9604 www.golder.com
TITLE GENERAL DETAILS (2 OF 3)	
PROJECT No. 1520359	CONTROL
Rev. 0	4 of 8 DRAWING D2

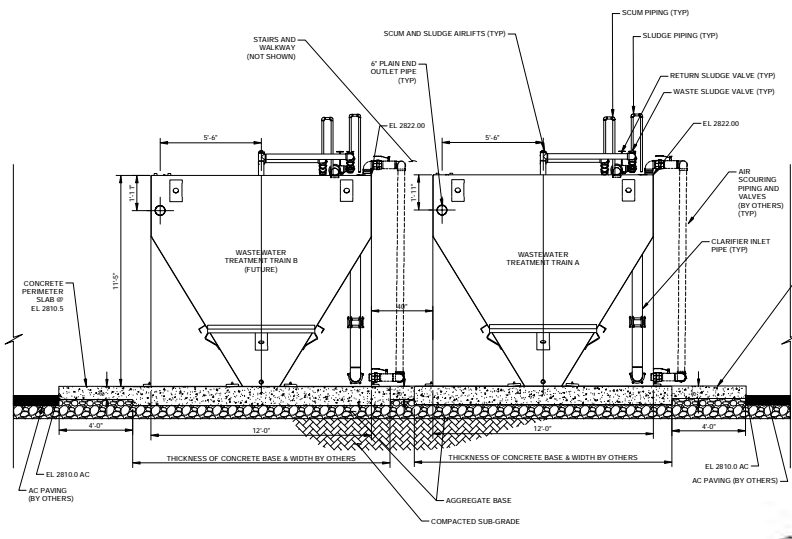

NTS 1 WASTEWATER TREATMENT PLANT SECTION (NOTE 1)

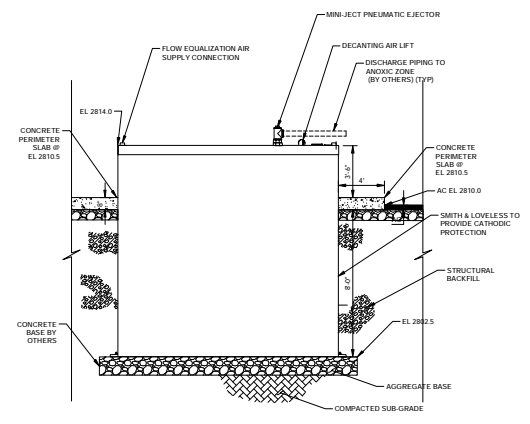

NTS 2 SLUDGE HOLDING TANK SECTION (NOTE 1)



ISSUED FOR CONSTRUCTION

- NOTES:
 1. EQUIPMENT DRAWINGS BY SMITH & LOVELESS, INC. 2015.

0	2016-05-02	ISSUED FOR CONSTRUCTION	EMC	AJS	JC	MPB
Rev	YYYY-MM-DD	DESCRIPTION	PREPARED	DESIGN	REVIEW	APPROVED

CLIENT:
 DOUBLE M CONSTRUCTION
 C/O SPRING MOUNTAIN RACEWAY, LLC

CONSULTANT:
 RENO OPERATIONS
 595 DOUBLE EAGLE CT. #1000
 RENO, NEVADA 89521
 USA
 (775) 828 9604
 www.gobdr.com

PROJECT:
 WASTEWATER DESIGN
 SPRING MOUNTAIN MOTORSPORTS RANCH
 PAHRUMP, NEVADA

TITLE:
 GENERAL DETAILS (3 OF 3)

PROJECT No. 1520359 CONTROL Rev. 0 4 of 8 DRAWING D3

**APPENDIX B
GEOTECHNICAL REPORT**

July 9, 2015

Project No. 1520359

Russ Meads
Double M Construction
2170 S. Cortina Ave.
Pahrump, NV 89045

RE: GEOTECHNICAL INVESTIGATION, WASTE WATER TREATMENT FACILITY RAPID INFILTRATION BASINS, SPRING MOUNTAIN MOTORSPORTS RANCH, PAHRUMP, NYE COUNTY, NEVADA

Dear Mr. Meads:

Golder Associates Inc. (Golder) is pleased to present the results of our geotechnical field investigation conducted for design of the proposed water treatment facility rapid infiltration basins (RIB) for the Spring Mountain Motorsports Ranch (SMMR). The SMMR is located at 3601 State Highway 160, Pahrump, Nye County, Nevada in Sections 33 and 34, Township 20 South, Range 54 East (MDBM). The proposed RIB site is located in the infield of the east track of the raceway.

This geotechnical investigation program was developed using guidelines presented in the Water Technical Sheet 3 (*Guidance Document for an Application for Rapid Infiltration Basins*, March 30, 1993) prepared by the Nevada Division of Environmental Protection (NDEP), Bureau of Water Pollution Control. Geotechnical design parameters and recommendations presented in this letter are based on the findings of our research, field exploration, and laboratory testing program.

1.0 SITE CONDITIONS

The site has been partially re-graded and, based on field observations, the existing ground surface is estimated to be about one to three feet lower than the original ground surface.

Surface materials generally consisted of Well Graded Gravel with Silt and Sand (GW-GM) with cobbles and boulders up to 12 inches in nominal diameter. The existing vegetative cover consists of sparse low scrub and grasses. Windrows about one foot high are present as a result of the partial re-grading. Two roughly graded dirt roads transverse the RIB area.



Photo #1 – Site Surface Conditions, looking west

s:\spring mountain motorsports ranch\1520359 water design - uepa\200_wastewater treatment\geotechnical investigation\letter\1520359 geotechnical letter-final.docx

Golder Associates Inc.
595 Double Eagle Court, Suite 1000
Reno, NV 89521 USA

Tel: (775) 828-9604 Fax: (775) 828-9645 www.golder.com



Golder Associates: Operations in Africa, Asia, Australasia, Europe, North America and South America

Golder, Golder Associates and the GA globe design are trademarks of Golder Associates Corporation

2.0 GEOTECHNICAL FIELD EXPLORATION

The geotechnical field exploration was conducted from June 10th to June 12th, 2015 and was supervised by Golder's field engineer from our Reno, Nevada office. The exploration program consisted of:

- Excavating two test pits to a minimum depth of 15 feet below the existing ground surface (bgs).
- Conducting four double-ring infiltration tests within the test pits.
- Drilling one boring within the footprint of the proposed RIB site.
- Installation of a temporary well within the boring to obtain a water quality sample.

Test pits and boring locations are shown on Figure 1. Golder provided the locations to Classic Homes, who subsequently staked the locations in the field and cleared the sites for utilities. The boring and test pits were logged by our field engineer, and the logs are presented in Attachment 1, along with a description of the Unified Soil Classification System (USCS) (ASTM D2488) used to classify the materials.

Stratigraphic contacts indicated on the logs represent the approximate boundaries between soil units; actual transitions may be more gradual. It should be noted that subsurface water conditions observed in the field during our field investigation can fluctuate depending on variations in seasonal precipitation and other factors.

2.1 Drilling

Boring BH-01 was drilled to a total depth of 150 feet bgs using hollow stem auger drilling methods with a CME-85 rig operated by National EWP from Las Vegas, Nevada. Driven samples were retrieved from the boring at 5-foot intervals from the ground surface to a depth of 40 feet bgs and at 10-foot intervals from a depth of 40 feet bgs to the terminal drilling depth of 150 feet bgs. Samples were collected using a Standard Penetration Test (SPT) split spoon sampler (2 inch O.D. and 1½ inch I.D.). The sampler was driven 18 inches (unless otherwise noted) at each sample interval into the soils beneath the base of the boring using a 140-pound automatic hammer with a 30-inch drop in accordance with ASTM D 1586. Hammer blows were recorded in 6-inch intervals for each sample and are presented on the borings logs. The penetration resistance (N-value) of the soil was calculated as the sum of the number of hammer blows required to drive the sampler the final 12 inches. The N-value is an indication of the relative density of cohesionless soils and the apparent consistency of cohesive soils. Generally, if a total of 50 blows were recorded for a single 6-inch interval, the test was terminated and the blow count was recorded as 50 blows for the inches of penetration observed. All blow counts presented on the boring logs are uncorrected values and do not take into consideration the efficiency of the automatic hammer, overburden, or other influences. Soil samples were collected, sealed in plastic bags, and returned to our office in Reno, Nevada.

2.2 Test Pits

Test pits TP-01 and TP-02 were excavated to depths of about 15 to 15½ feet bgs using a John Deere 310 rubber-tired backhoe operated by Double M Construction of Pahrump, Nevada. A composite sample was collected from both test pits from a depth of about 1 to 15 feet bgs and returned to Golder's Reno, Nevada office.

2.3 Geotechnical Laboratory Testing

Geotechnical laboratory tests were performed on a sample from a depth of 100 feet in Boring BH-01 and the composite sample from the test pits to verify field soil classifications and to assist in the development of engineering recommendations. Geotechnical laboratory testing included grain size distribution (ASTM D 422), Atterberg limits (ASTM D 4318), and as-received laboratory moisture content (ASTM D 2216). Tests were performed by Construction Materials Engineers, Inc. (CME) of Reno, Nevada. Results of the individual laboratory tests are presented in Attachment 2.



3.0 SUBSURFACE SOIL AND WATER CONDITIONS

Based on a review of the *Geologic Map of Nevada* (Nevada Bureau of Mines and Geology, Stewart and Carlson, 1978), the raceway overlies alluvial outwash deposits from the Spring Mountain Range.

The subsurface profile from the ground surface to a depth of about 71½ feet generally consisted of light brown to brown, native Well Graded Gravel with Silt and Sand (GW-GM) to Silty Gravel (GM) mostly consisting of relatively dense to very dense, fine to medium, subrounded to rounded gravel, with some fine to coarse sand and little nonplastic fines. Sub-rounded to rounded cobbles and boulders up to 12 inches in nominal diameter were observed in the test pit excavations from about ½ to 6½ feet bgs. SPT sample refusal was encountered at less than six inches in many of the SPT samples, likely due to the presence of oversized gravel and cobbles (particles larger than the sampler diameter); therefore, blow counts presented on the boring logs may be overestimated.

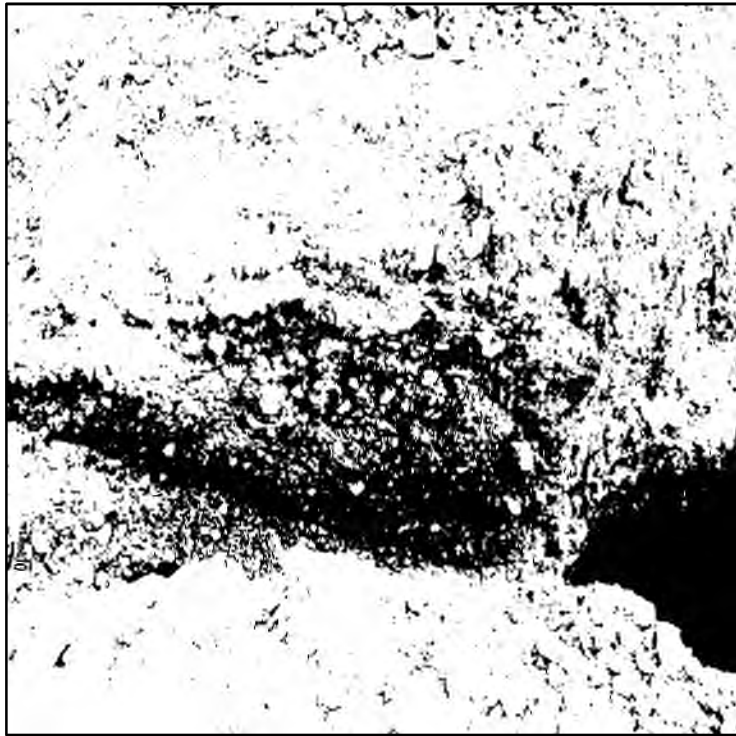

Photo #2 – Test Pit TP-01, Looking West

A localized lens of very dense, light brown, nonplastic Silty Sand with Gravel (SM) with mostly fine to coarse sand and fine subrounded gravel was observed on the east side of Test Pit TP-01 from depth a depth of 8 to 11 feet; however, this lens was not observed in TP-02 so is not considered continuous.

Native Sandy Silt (ML) and Sandy Lean Clay (CL) were encountered from about 71½ to 151½ feet bgs. These materials were generally brown to light brown, moist, nonplastic to low plastic with little fine to medium sand and trace fine gravel, and very stiff to hard apparent consistencies.

Samples were dry from about the ground surface to about 41½ feet bgs, moist from approximately 41½ to 65 feet bgs, and wet from 65 to 71½ feet bgs. The depth to groundwater was measured in the boring at 11:50 a.m. on June 10th at a depth of about 67 feet bgs.

4.0 TEMPORARY WELL CONSTRUCTION AND SAMPLING

A temporary well was installed in Boring BH-01 on June 10th and abandoned on June 11th. Two-inch diameter slotted PVC pipe was installed from 60 to 80 feet bgs and solid two-inch diameter PVC pipe was installed from the ground surface to 60 feet bgs. The hole was abandoned from a depth of 85 to 151½ feet bgs with bentonite chips. No. 3 sand was placed around the slotted PVC pipe from a depth of 58 to 85 feet bgs, and bentonite chips were placed as a seal around the solid PVC pipe from 50 to 58 feet bgs, with the remainder of the solid PVC casing remaining inside the hollow stem auger from 50 feet bgs to the ground surface. Prior to water sampling, the depth to water was measured at 68 feet bgs in the standpipe at 7:50 am on June 11th.



EFFEX Analytical Services (EFFEX) of Las Vegas, Nevada was retained by Classic Homes to perform Nevada Department of Environmental Protection's (NDEP) analytical Profile 1 testing. Water sampling materials were provided to Golder by EFFEX. Water was purged from the well prior to leaving the site on June 10th and the well was purged again on the morning of June 11th. In total, about 6 to 7 times the well volume was purged prior to sampling.

Golder collected water samples in the prepared sample bottles and stored them in a cooler with ice, and Classic Homes delivered them to EFFEX on June 11th. After the samples were obtained, the well was abandoned in accordance with State of Nevada regulations.

5.0 DOUBLE RING INFILTRATION TESTS

Four double ring infiltration tests were conducted at depths of 5 and 10 feet in Test Pit TP-01 and at 10 and 15 feet in TP-02. As previously noted in Section 3.0, materials at between 8 and 11 feet bgs were observed to be horizontally discontinuous with varying densities (dense to very dense) and material types (Well Graded Gravel to Silty Sand). Therefore, two infiltration tests were performed at this depth within the test pits in order to evaluate variations in the infiltration rate due to the discontinuities.

Equipment included two solid metal rings, an inner ring with a 12-in internal diameter and an outer ring with a 22.5-in internal diameter. The test area was levelled and the inner and outer rings were driven two inches into the soil and the soil was presoaked for an hour prior to conducting the test. Water was placed in both rings to a minimum depth of 4 inches and water depth measurements were recorded at 30-minute intervals for one hour. The drop in water level of the inner ring during the last 30-minute interval was used to determine the time interval between readings during the test. If the water interval dropped 2 inches or more in the inner ring then measurements were taken at 10-minute intervals for the test. If the water level dropped less than 2 inches in the inner ring, test measurements were taken at 30-minute intervals.

Infiltration testing was performed after the presoak was complete and the measurement interval was determined. The rings were filled with water to a minimum depth of 4 inches for eight consecutive readings, or until a stabilized rate was achieved. A stabilized rate was considered to occur when a difference of a ¼-inch or less was observed between the highest and lowest measurement for four consecutive readings. The infiltration rate was determined from the drop in water level within the inner ring that occurred during the final interval. Test results are presented in Table 1 and field data is presented in Attachment 3.

Table 1: Summary of Double Ring Infiltrometer Test Results

Location and Depth	Soil Type	Infiltration Rate (inches/hour)
TP-01 @ 5 ft	GW-GM	13.5
TP-01 @ 10 ft	SM	0.5
TP-02 @ 10 ft	GW-GM	4.5
TP-02 @ 15 ft	GW-GM	21

6.0 CONCLUSIONS AND RECOMMENDATIONS

As noted in Table 1, the infiltration rate at 10 feet varied with an average infiltration rate of 2.5 in/hr. Averaging this value with the more coarse soil above and below provides an overall infiltration rate in the proposed RIB area of about 12.3 in/hr to a depth of 10 feet below the proposed bottom elevation of the RIBs. However, it is recommended that the design infiltration rate be reduced by averaging all four test results providing a more conservative design infiltration rate of 9.9 in/hour to account for variations in soil types and in situ densities of the native materials.



7.0 CLOSING

Golder appreciates the opportunity to continue working with Classic Homes at the Spring Mountain Motorsports Ranch. If you have any questions or comments regarding the information presented herein, please contact us at 775-828-9604.

Sincerely,

GOLDER ASSOCIATES INC.

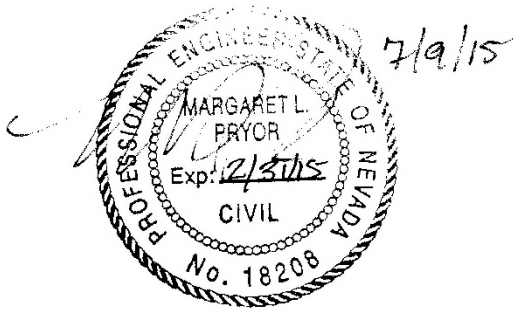

Margaret Pryor, P.E.
Senior Project Geotechnical Engineer

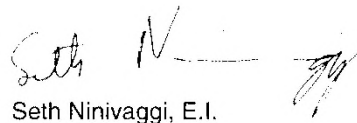

Seth Ninivaggi, E.I.
Staff Geologist

Attachments:

- Figure – Geotechnical Exploration Location Map
- Attachment 1 – Boring and Test Pit Logs
- Attachment 2 – Laboratory Soil Test Results
- Attachment 3 – Double Ring Infiltration Test Field Data

SN/MP/RAB/ap
15178.doc



FIGURES

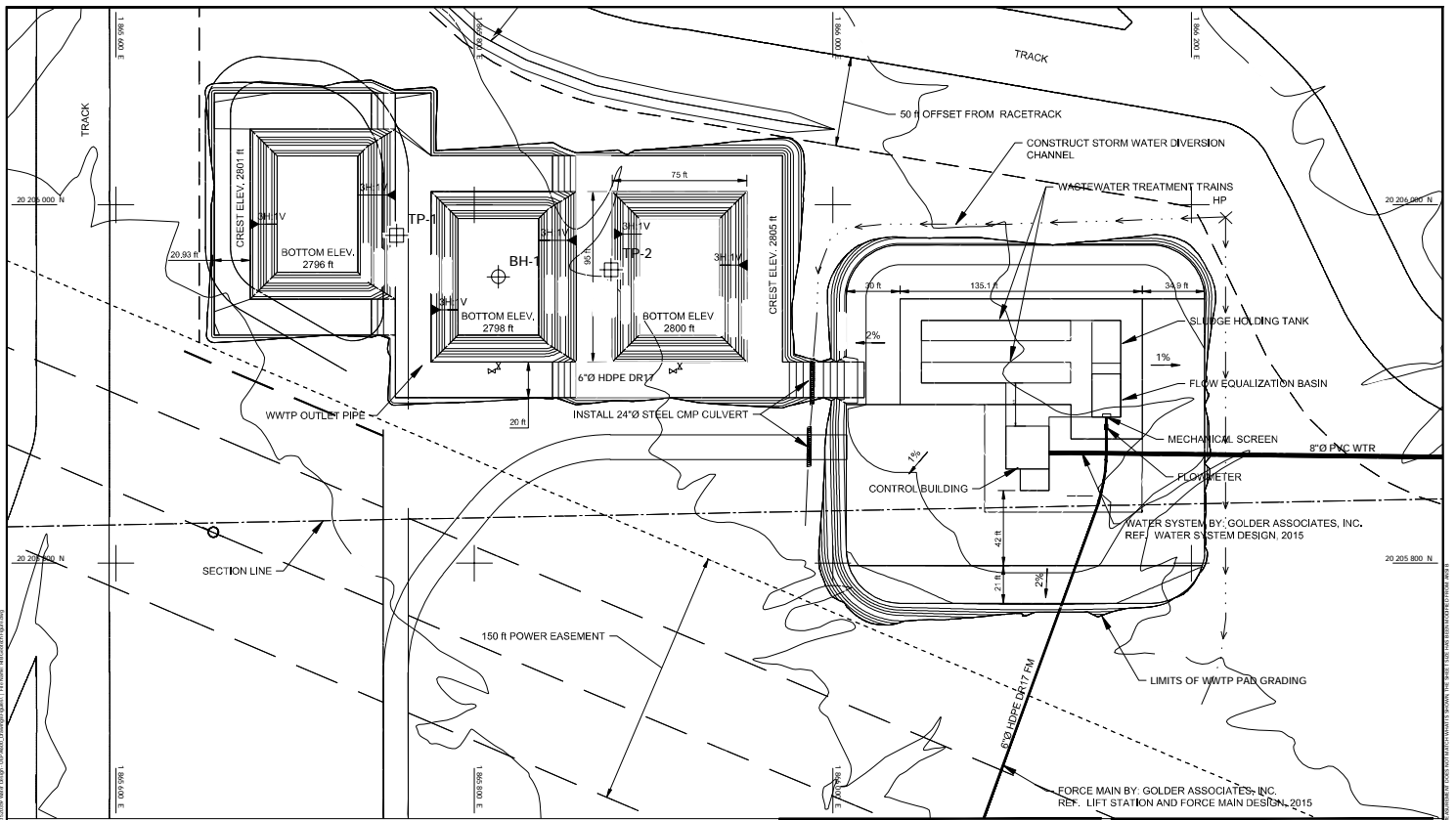

LEGEND

	BH-1	APPROXIMATE BORING LOCATION
	TP-1	APPROXIMATE PERCOLATION TEST PIT LOCATION

CLIENT DOUBLE M CONSTRUCTION	PROJECT WASTEWATER DESIGN SPRING MOUNTAIN MOTORSPORTS RANCH PAHRUMP, NEVADA														
CONSULTANT 	TITLE GEOTECHNICAL EXPLORATION LOCATION MAP														
<table border="0"> <tr><td>DESIGNED</td><td>MP</td></tr> <tr><td>PREPARED</td><td>JSL</td></tr> <tr><td>REVIEWED</td><td>MPB</td></tr> <tr><td>APPROVED</td><td>MPB</td></tr> </table>	DESIGNED	MP	PREPARED	JSL	REVIEWED	MPB	APPROVED	MPB	<table border="0"> <tr><td>DATE</td><td>2015-05-15</td></tr> <tr><td>PROJECT NO.</td><td>1520359</td></tr> <tr><td>REV.</td><td>###</td></tr> </table>	DATE	2015-05-15	PROJECT NO.	1520359	REV.	###
DESIGNED	MP														
PREPARED	JSL														
REVIEWED	MPB														
APPROVED	MPB														
DATE	2015-05-15														
PROJECT NO.	1520359														
REV.	###														

**ATTACHMENT 1
BORING AND TEST PIT LOGS**



LOG OF BORING: BH-1

CLIENT: Classic Homes
 PROJECT: Spring Mountain Raceway
 LOCATION: Pahrump, Nye County, Nevada N:, E:
 PROJECT NO.: 1520359

SHEET: 1 OF 5
 COMPANY: National
 LOGGED: SAN DATE: 6/10/15
 CHECKED: MLP DATE: 6/19/15

Drilling			Sampling					Material Description							
WATER	DEPTH	LAYER ELEVATION	1ST BLOW CNT	2ND BLOW CNT	3RD BLOW CNT	N VALUE	SAMPLE TYPE	SAMPLE NUMBER	GRAPHIC LOG	ASTM	SOIL NAME, density, plasticity or particle size, color, moisture, minor components	MOISTURE	DRY DENSITY	ADDITIONAL LAB TESTING	WELL DIAGRAM
	0														Solid PVC in Hollow Stem Auger from surface to 50 feet BGS.
	5.0		50			50/6	SPT	1			GW-GM, Well Graded Gravel with Silt and Sand, light brown, very dense, little nonplastic fines, little fine to coarse sand, mostly fine to coarse round to subrounded gravel up to 3 inches, cobbles up to 12 inches of sandstone and siltstone, estimated from surface. NOTE: NO sample recovery at 5 feet below surface.	dry			
	10.0		40	40	50/5	90/11	SPT	2			GW-GM, Well Graded Gravel with Silt and Sand, light brown, very dense, little nonplastic fines, some fine to coarse sand, mostly fine to coarse round to subrounded gravel larger than 1.5 inches.	dry			
	15.0		39			39/5	SPT	3							
	20.0		44	50/5		94/11	SPT	4							
	25.0		50/5			50/5	SPT	5			SW-SM, Well Graded Sand with Silt and Gravel, light brown, very dense, little nonplastic fines, mostly fine to coarse sand, some fine to coarse round to subrounded gravel up to 3 inches.	dry			
	30.0		43	50/3		93/9	SPT	6			GW-GM, Well Graded Gravel with Silt and Sand, light brown, very dense, little nonplastic fines, some fine to coarse sand, mostly fine to coarse round to subrounded gravel larger than 1.5 inches.	dry			
	35.0														

RENO - TEST PIT LOG-3 SPRING MOUNTAIN MOTORSPORTS RANCH.GPJ GLDR_IRV.GDT 7/7/15

Report of borehole must be read in conjunction with accompanying notes and abbreviations



LOG OF BORING: BH-1

CLIENT: Classic Homes
 PROJECT: Spring Mountain Raceway
 LOCATION: Pahrump, Nye County, Nevada N:, E:
 PROJECT NO.: 1520359

SHEET: 2 OF 5
 COMPANY: National
 LOGGED: SAN DATE: 6/10/15
 CHECKED: MLP DATE: 6/19/15

Drilling			Sampling					Material Description							
WATER	DEPTH	LAYER ELEVATION	1ST BLOW CNT	2ND BLOW CNT	3RD BLOW CNT	N VALUE	SAMPLE TYPE	SAMPLE NUMBER	GRAPHIC LOG	ASTM	SOIL NAME, density, plasticity or particle size, color, moisture, minor components	MOISTURE	DRY DENSITY	ADDITIONAL LAB TESTING	WELL DIAGRAM
	35		38	50/4		88/10	SPT	7			GW-GM, Well Graded Gravel with Silt and Sand, light brown, very dense, little nonplastic fines, some fine to coarse sand, mostly fine to coarse round to subrounded gravel larger than 1.5 inches. (continued)	dry			Solid PVC in Hollow Stem Auger from surface to 50 feet BGS.
	40	40.0	13	50/4		63/10	SPT	8			SW-SM, Well Graded Sand with Silt and Gravel, light brown, very dense, little nonplastic fines, mostly fine to coarse sand, some fine to coarse round to subrounded gravel up to 1.5 inches.	dry to damp			
	50		5	50/4		55/10	SPT	9							
	60	60.0	14	50/5		64/11	SPT	10			GW-GM, Well Graded Gravel with Silt and Sand, light brown, very dense, little nonplastic fines, some fine to coarse sand, mostly fine to coarse round to subrounded gravel larger than 1.5 inches, probable cobbles.	damp			Solid PVC in #3 Sand from 58 to 85 feet BGS.
	67										Ground water encountered at 67 feet BGS.				Slotted PVC in #3 Sand from 60 to 80 feet BGS.
	70														

RENO - TEST PIT LOG-3, SPRING MOUNTAIN MOTORSPORTS RANCH.GPJ GLDR_IRV.GDT 7/7/15

Report of borehole must be read in conjunction with accompanying notes and abbreviations



LOG OF BORING: BH-1

CLIENT: Classic Homes
 PROJECT: Spring Mountain Raceway
 LOCATION: Pahrump, Nye County, Nevada N:, E:
 PROJECT NO.: 1520359

SHEET: 3 OF 5
 COMPANY: National
 LOGGED: SAN DATE: 6/10/15
 CHECKED: MLP DATE: 6/19/15

Drilling			Sampling					Material Description							
WATER	DEPTH	LAYER ELEVATION	1ST BLOW CNT	2ND BLOW CNT	3RD BLOW CNT	N VALUE	SAMPLE TYPE	SAMPLE NUMBER	GRAPHIC LOG	ASTM	SOIL NAME, density, plasticity or particle size, color, moisture, minor components	MOISTURE	DRY DENSITY	ADDITIONAL LAB TESTING	WELL DIAGRAM
	70		11	29	50/4	79/10	SPT	11			GW-GM, Well Graded Gravel with Silt and Sand, light brown, very dense, little nonplastic fines, some fine to coarse sand, mostly fine to coarse round to subrounded gravel larger than 1.5 inches, probable cobbles. (continued)	sat.			Slotted PVC in #3 Sand from 60 to 80 feet BGS.
	80	80.0	38	50/6		88/12	SPT	12			CL, Sandy Lean Clay with Sand and Gravel, brown, very stiff to hard, mostly low plasticity fines, some fine to coarse sand, little fine subrounded gravel up to 0.5 inches.	moist			#3 Sand with no pipe 80 to 85 feet BGS.
	90	90.0	21	31	35	66	SPT	13			SM, Silty Sand with Gravel, brown, very dense, some low plasticity fines, mostly fine to medium sand, little fine subangular to subrounded gravel up to 1 inch.	very moist			Bentonite Chips from 85 to 151.5 feet BGS.
	100	100.0	18	19	25	44	SPT	14			CL, Sandy Lean Clay, brown, hard, mostly low plasticity fines, some fine to medium sand.	moist			
	165														

RENO - TEST PIT LOG-3 SPRING MOUNTAIN MOTORSPORTS RANCH.GPJ GLDR_IRV.GDT 7/7/15

Report of borehole must be read in conjunction with accompanying notes and abbreviations



LOG OF BORING: BH-1

CLIENT: Classic Homes
 PROJECT: Spring Mountain Raceway
 LOCATION: Pahrump, Nye County, Nevada N:, E:
 PROJECT NO.: 1520359 ELEVATION:

SHEET: 4 OF 5
 COMPANY: National
 LOGGED: SAN DATE: 6/10/15
 CHECKED: MLP DATE: 6/19/15

Drilling			Sampling					Material Description							
WATER	DEPTH	LAYER ELEVATION	1ST BLOW CNT	2ND BLOW CNT	3RD BLOW CNT	N VALUE	SAMPLE TYPE	SAMPLE NUMBER	GRAPHIC LOG	ASTM	SOIL NAME, density, plasticity or particle size, color, moisture, minor components	MOISTURE	DRY DENSITY	ADDITIONAL LAB TESTING	WELL DIAGRAM
	105										CL, Sandy Lean Clay, brown, hard, mostly low plasticity fines, some fine to medium sand. (continued)				Bentonite Chips from 85 to 151.5 feet BGS.
	110	110.0	19	20	27	47	SPT	15			ML, Sandy Silt, brown, hard, mostly low to medium plasticity fines, some fine to medium sand, trace fine gravel.	moist			
	120		24	27	30	57	SPT	16							
	130	130.0	20	28	32	60	SPT	17			CL, Sandy Lean Clay, light brown, hard to very stiff, mostly low to medium plasticity fines, some fine to medium sand, trace fine gravel from 130 to 140 feet.	moist			
	140														

RENO - TEST PIT LOG-3, SPRING MOUNTAIN MOTORSPORTS RANCH.GPJ GLDR_IRV.GDT 7/7/15

Report of borehole must be read in conjunction with accompanying notes and abbreviations



LOG OF BORING: BH-1

CLIENT: Classic Homes
 PROJECT: Spring Mountain Raceway
 LOCATION: Pahrump, Nye County, Nevada N:, E:
 PROJECT NO.: 1520359 ELEVATION:

SHEET: 5 OF 5
 COMPANY: National
 LOGGED: SAN DATE: 6/10/15
 CHECKED: MLP DATE: 6/19/15

Drilling			Sampling					Material Description							
WATER	DEPTH	LAYER ELEVATION	1ST BLOW CNT	2ND BLOW CNT	3RD BLOW CNT	N VALUE	SAMPLE TYPE	SAMPLE NUMBER	GRAPHIC LOG	ASTM	SOIL NAME, density, plasticity or particle size, color, moisture, minor components	MOISTURE	DRY DENSITY	ADDITIONAL LAB TESTING	WELL DIAGRAM
	140		19	30	31	61	SPT	18			CL, Sandy Lean Clay, light brown, hard to very stiff, mostly low to medium plasticity fines, some fine to medium sand, trace fine gravel from 130 to 140 feet. (continued)	moist			Bentonite Chips from 85 to 151.5 feet BGS.
	145														
	150		7	27	30	57	SPT	19							
	151.5										Bottom of borehole at 151.5 feet. Groundwater encountered at 67 feet below ground surface. June 10th at 11:50 am.				

RENO - TEST PIT LOG-3 SPRING MOUNTAIN MOTORSPORTS RANCH.GPJ GLDR_IRV.GDT 7/7/15

Report of borehole must be read in conjunction with accompanying notes and abbreviations



TEST PIT LOG

No. TP-01

CLIENT CLASSIC HOMES PROJECT SPRING MOUNTAIN RACEWAY
 TEMP N/A *F WEATHER N/A ENGINEER S. NINIVAGGI OPERATOR N/A
 EQUIPMENT John Deere Backhoe CONTRACTOR N/A DATE 6/10/15
 COORDINATES N N/A E N/A ELEV. N/A DATUM N/A JOB 1520359
 LOCATION PAHRUMP, NYE COUNTY, NEVADA TIME 1500

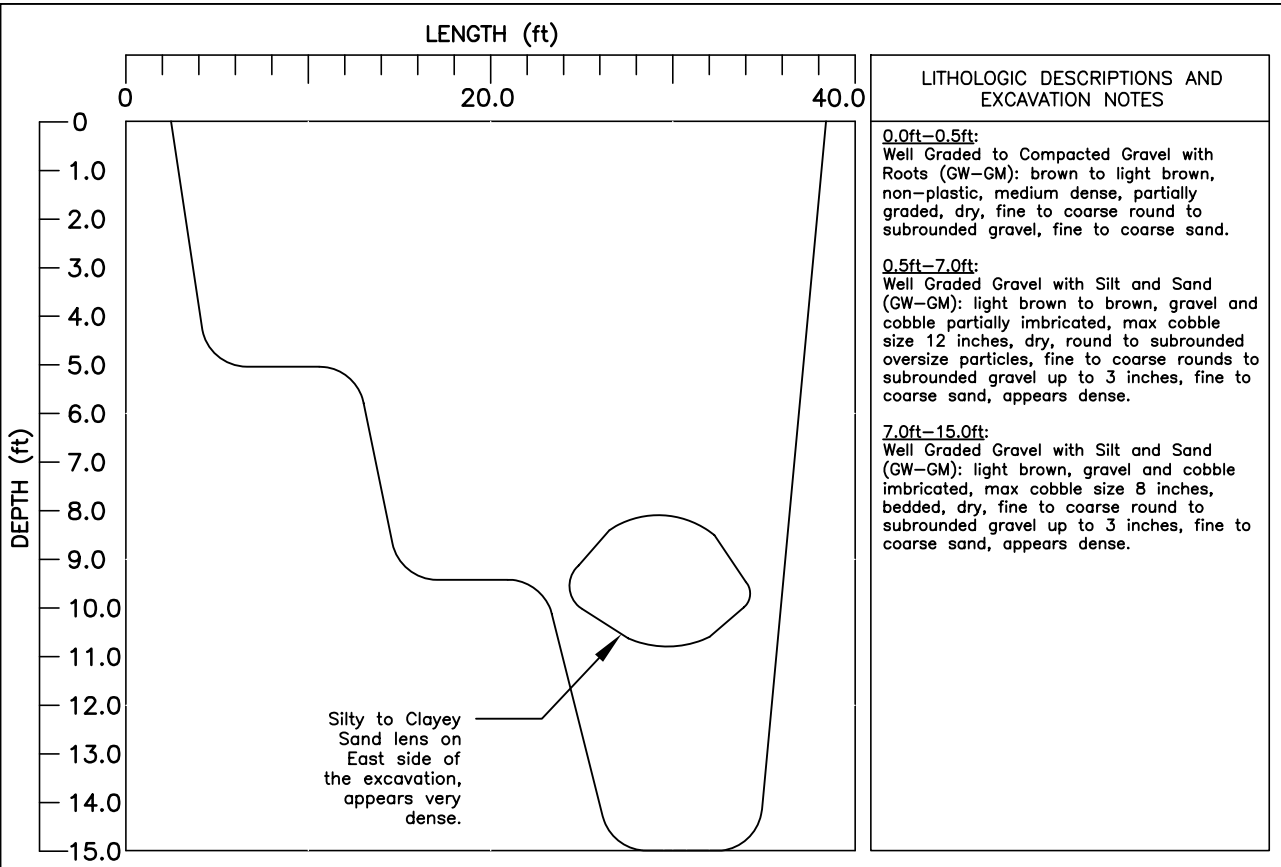

SPECIAL NOTES

(1.) TOTAL DEPTH OF 15.0' BGS.
 (2.) NO GROUNDWATER ENCOUNTERED.
 (3.) ONE COMPOSITE SAMPLE WAS TAKEN FOR BOTH TEST PITS.
 (4.) 8.0ft-11.0ft: Silty to Clayey Sand Lens on East 10 ft bench, Not seen on West wall. Brown with nonplastic fines, fine to coarse sand, fine to coarse round to subrounded gravel up to 1 inch, very dense.
 (5.) Slight variations in percent gravel and percent sand form sub-horizontal discontinuous beds throughout excavation.

LEGEND	CHECK: SAN REVIEW:MLP
BG=SMALL BAG SAMPLE	
BK=BULK BAG SAMPLE	
T=2.5"Ø TUBE SAMPLE	

Thursday, July 09, 2015 -- 9:36am
 FILE: \\veno\data\Spring Mountain Motorsports Ranch\1520359 Water Design - UEPA\200_Wastewater Treatment\Geotechnical Investigation\Field Data\Test Pit Log\CAD Logs\Test Pit Logs.dwg TAB NAME \TP-01
 THIS DRAWING HAS BEEN PREPARED BY GOLDBER ASSOCIATES INC. FOR USE BY THE CLIENT NAMED IN THE TITLE BLOCK. GOLDBER ASSOCIATES INC. SHALL NOT BE LIABLE FOR THE USE OF THIS DRAWING ON ANY OTHER FACILITY OR FOR ANY OTHER PURPOSES.



TEST PIT LOG

No. TP-02

CLIENT CLASSIC HOMES PROJECT SPRING MOUNTAIN RACEWAY
 TEMP N/A °F WEATHER N/A ENGINEER S. NINIVAGGI OPERATOR N/A
 EQUIPMENT John Deere Backhoe CONTRACTOR N/A DATE 6/10/15
 COORDINATES N N/A E N/A ELEV. N/A DATUM N/A JOB 1520359
 LOCATION PAHRUMP, NYE COUNTY, NEVADA TIME 1600

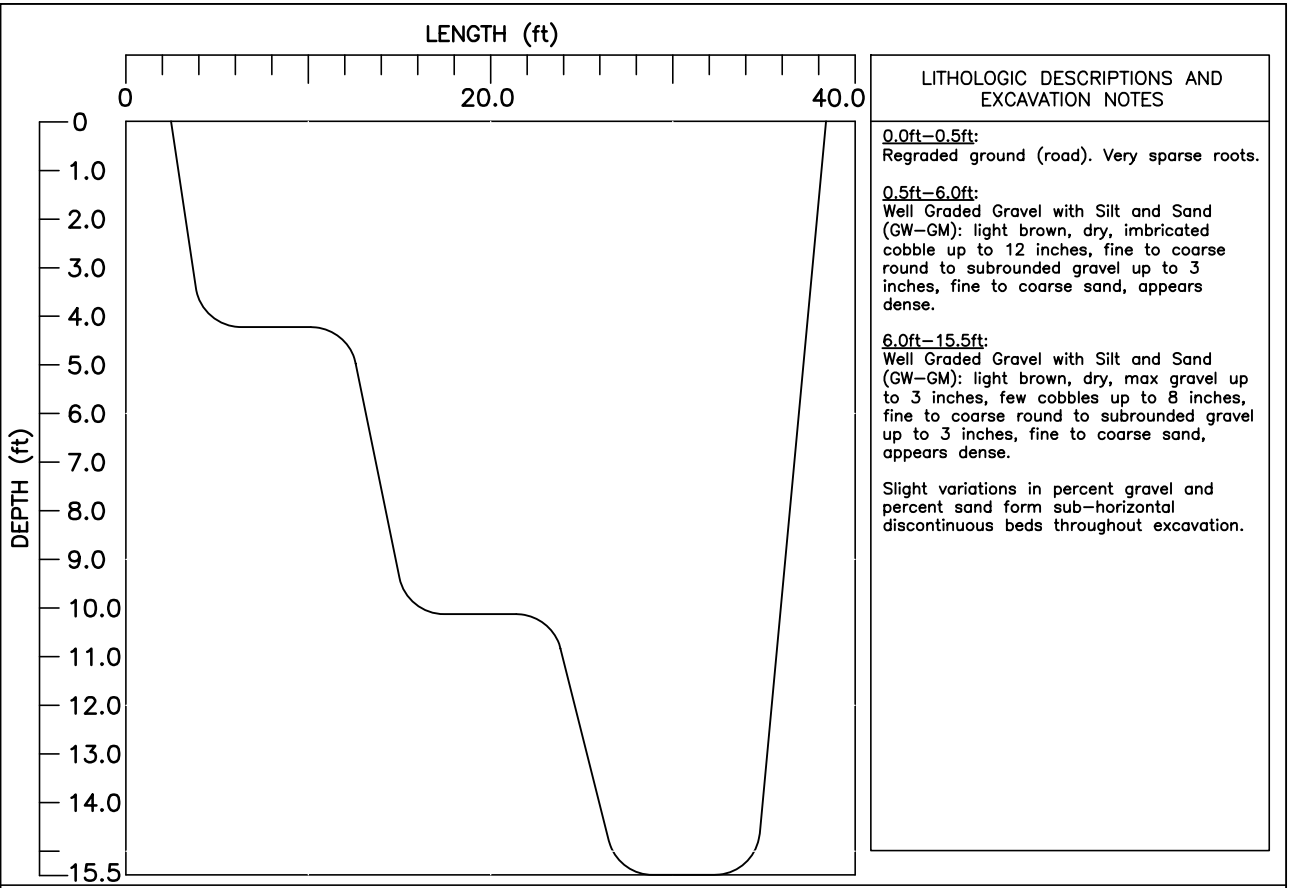

LITHOLOGIC DESCRIPTIONS AND EXCAVATION NOTES

0.0ft-0.5ft:
 Regraded ground (road). Very sparse roots.

0.5ft-6.0ft:
 Well Graded Gravel with Silt and Sand (GW-GM): light brown, dry, imbricated cobble up to 12 inches, fine to coarse round to subrounded gravel up to 3 inches, fine to coarse sand, appears dense.

6.0ft-15.5ft:
 Well Graded Gravel with Silt and Sand (GW-GM): light brown, dry, max gravel up to 3 inches, few cobbles up to 8 inches, fine to coarse round to subrounded gravel up to 3 inches, fine to coarse sand, appears dense.

Slight variations in percent gravel and percent sand form sub-horizontal discontinuous beds throughout excavation.

SPECIAL NOTES

(1.) TOTAL DEPTH OF 15.5' BGS.
 (2.) NO GROUNDWATER ENCOUNTERED.
 (3.) ONE COMPOSITE SAMPLE WAS TAKEN FOR BOTH TEST PITS.

LEGEND		CHECK: SAN REVIEW:MLP
BG=SMALL BAG SAMPLE		
BK=BULK BAG SAMPLE		
T=2.5"Ø TUBE SAMPLE		

Thursday, July 09, 2015 -- 9:36am
 FILE: \\Veno\data\Spring Mountain Motorsports Ranch\1520359 Water Design - UEPA\200_Wastewater Treatment\Geotechnical Investigation\Field Data\Test Pit Log\CAD Logs\Test Pit Logs.dwg TAB NAME \TP-02
 THIS DRAWING HAS BEEN PREPARED BY GOLDER ASSOCIATES INC. FOR USE BY THE CLIENT NAMED IN THE TITLE BLOCK. GOLDER ASSOCIATES INC. SHALL NOT BE LIABLE FOR THE USE OF THIS DRAWING ON ANY OTHER FACILITY OR FOR ANY OTHER PURPOSES.

UNIFIED SOIL CLASSIFICATION SYSTEM (USCS)

CRITERIA FOR ASSIGNING GROUP SYMBOLS AND NAMES			SOIL CLASSIFICATION GENERALIZED GROUP DESCRIPTIONS	
COARSE-GRAINED SOILS MORE THAN 50% RETAINED ON NO. 200 SIEVE	GRAVELS MORE THAN 50% OF COARSE FRACTION RETAINED ON NO. 4 SIEVE	CLEAN GRAVELS LESS THAN 5% FINES	GW	WELL-GRADED GRAVELS
			GP	POORLY-GRADED GRAVELS
		GRAVELS WITH FINES MORE THAN 12% FINES	GM	GRAVEL AND SILT MIXTURES
			GC	GRAVEL AND CLAY MIXTURES
	SANDS 50% OR MORE OF COARSE FRACTION PASSES NO. 4 SIEVE	CLEAN SANDS LESS THAN 5% FINES	SW	WELL-GRADED SANDS
			SP	NON- AND LOW-POORLY-GRADED SANDS
		SANDS WITH FINES MORE THAN 12% FINES	SM	SAND AND SILT MIXTURES
			SC	SAND AND CLAY MIXTURES
FINE-GRAINED SOILS 50% OR MORE PASSES THE NO. 200 SIEVE	SILTS AND CLAYS LIQUID LIMIT LESS THAN 50	INORGANIC	CL	LOW-PLASTICITY CLAYS
			ML	NON-PLASTIC AND LOW-PLASTICITY SILTS
		ORGANIC	OL	NON- AND LOW- PLASTICITY ORGANIC CLAYS NON- AND LOW- PLASTICITY ORGANIC SILTS
	SILTS AND CLAYS LIQUID LIMIT GREATER THAN 50	INORGANIC	CH	HIGH-PLASTICITY CLAYS
			MH	HIGH-PLASTICITY SILTS
		ORGANIC	OH	HIGH-PLASTICITY ORGANIC CLAYS HIGH-PLASTICITY ORGANIC SILTS
HIGHLY ORGANIC SOILS	PRIMARILY ORGANIC MATTER, DARK IN COLOR, AND ORGANIC ODOR	PT	PEAT	

BASED ON: ASTM D2487-06

SOIL CONSISTENCY

COHESIONLESS SOILS ^(a)		
DENSITY	N _s , blows/ft. ^(c)	RELATIVE DENSITY (%)
VERY LOOSE	0 to 4	0 - 15
LOOSE	4 to 10	15 - 35
MEDIUM DENSE	10 to 30	35 - 65
DENSE	30 to 50	65 - 85
VERY DENSE	over 50	>85

COHESIVE SOILS ^(b)		
CONSISTENCY	N _s , blows/ft. ^(c)	UNDRAINED SHEAR STRENGTH (psf) ^(d)
VERY SOFT	0 to 2	<250
SOFT	2 to 4	250-500
FIRM	4 to 8	500-1000
STIFF	8 to 15	1000-2000
VERY STIFF	15 to 30	2000-4000
HARD	over 30	>4000

- (a) SOILS CONSISTING OF GRAVEL, SAND, AND SILT, EITHER SEPARATELY OR IN COMBINATION, POSSESSING NO CHARACTERISTICS OF PLASTICITY, AND EXHIBITING DRAINED BEHAVIOR.
 (b) SOILS POSSESSING THE CHARACTERISTICS OF PLASTICITY, AND EXHIBITING UNDRAINED BEHAVIOR.
 (c) REFER TO TEXT OF ASTM D 1586-84 FOR A DEFINITION OF N_s; IN NORMALLY CONSOLIDATED COHESIONLESS SOILS. RELATIVE DENSITY TERMS ARE BASED ON N VALUES CORRECTED FOR OVERBURDEN PRESSURES.
 (d) UNDRAINED SHEAR STRENGTH = 1/2 UNCONFINED COMPRESSION STRENGTH.

COMPONENT DEFINITIONS BY GRADATION

COMPONENT	SIZE RANGE
BOULDERS	ABOVE 300 mm (12 in)
COBBLES	75 mm (3 in) to 300 mm (12 in)
GRAVEL	4.75 mm (No. 4) to 75 mm (3 in)
COARSE GRAVEL	19 mm (3/4 in) to 75 mm (3 in)
FINE GRAVEL	4.75 mm (No. 4) to 19 mm (3/4 in)
SAND	0.075mm (No. 200) to 4.75mm (No. 4)
COARSE SAND	2.0 mm (No. 10) to 4.75 mm (No. 4)
MEDIUM SAND	0.42 mm (No. 40) to 2.0 mm (No. 10)
FINE SAND	0.075 mm (No. 200) to 0.42 mm (No. 40)
SILT AND CLAY	SMALLER THAN 0.075mm (No. 200)

QUALITATIVE DESCRIPTIVE TERMINOLOGY FOR MOISTURE CONTENT

DRY	NO DISCERNIBLE MOISTURE PRESENT
DAMP	ENOUGH MOISTURE PRESENT TO DARKEN THE APPEARANCE BUT WILL NOT MOISTEN THE HAND
MOIST	WILL MOISTEN THE HAND
Wet	VISIBLE WATER PRESENT ON MATERIALS

DESCRIPTIVE TERMINOLOGY DENOTING COMPONENT PROPORTIONS

DESCRIPTIVE TERMS	RANGE OF PROPORTION
TRACE	0-5%
FEW	5-10%
LITTLE	15-25%
SOME	30-45%

SILT AND CLAY DESCRIPTIONS

DESCRIPTION	TYPICAL UNIFIED DESIGNATION
SILT	ML (NON-PLASTIC)
CLAYEY SILT	CL-ML (LOW PLASTICITY)
CLAY	CL
FAT CLAY	CH
ELASTIC SILT	MH
ORGANIC SOILS	OL, OH, Pt

SAMPLE TYPES

SYMBOL	DESCRIPTION
SPT	2" O.D. SPLIT SPOON
BK	BULK
BG	BAGGIE
SH	SHELBY TUBE
MC	2 3/4" I.D. CAL. MOD. SAMPLER
HQ	DIAMOND ROCK CORE SAMPLE

SOIL CLASSIFICATION LEGEND



**ATTACHMENT 2
LABORATORY SOIL TEST RESULTS**

TABULATION OF TEST RESULTS

CLIENT: GOLDER ASSOCIATES											PROJECT NO: 1172										
PROJECT: SPRING MOUNTAIN RACEWAY Project No. 1520359											MATERIAL: SITE SOILS										
SIEVE ANALYSIS % PASSING																					
DATE	SAMPLE	LIQUID LIMIT	PLASTICITY INDEX	REC'D MOISTURE, %	MOISTURE DENSITY, pcf	50.8 mm (2")	37.5 mm (1 1/2")	25.4 mm (1")	19 mm (3/4")	12.5 mm (1/2")	9.5 mm (3/8")	4.75 mm (#4)	2.36 mm (#8)	2.0 mm (#10)	1.18 mm (#16)	600µm (#30)	425µm (#40)	300µm (#50)	150µm (#100)	75 µm (#200)	
6/23/2015	TEST PIT 1 & 2 COMBINED	NV	NONPLASTIC	1.6		100	97	86	78	65	58	45	36	35	31	28	27	25	22	12.8	
6/23/2015	BORING 01 AT 100.0-101.5'	37	15	25.9					100	95	92	87	85	84	83	82	82	82	79	67.3	



6890 Sierra Center Parkway, Suite 90
 Reno, NV 89511
 Ph: 775-851-8205 Fx: 775-851-8593

Particle Size Distribution Report

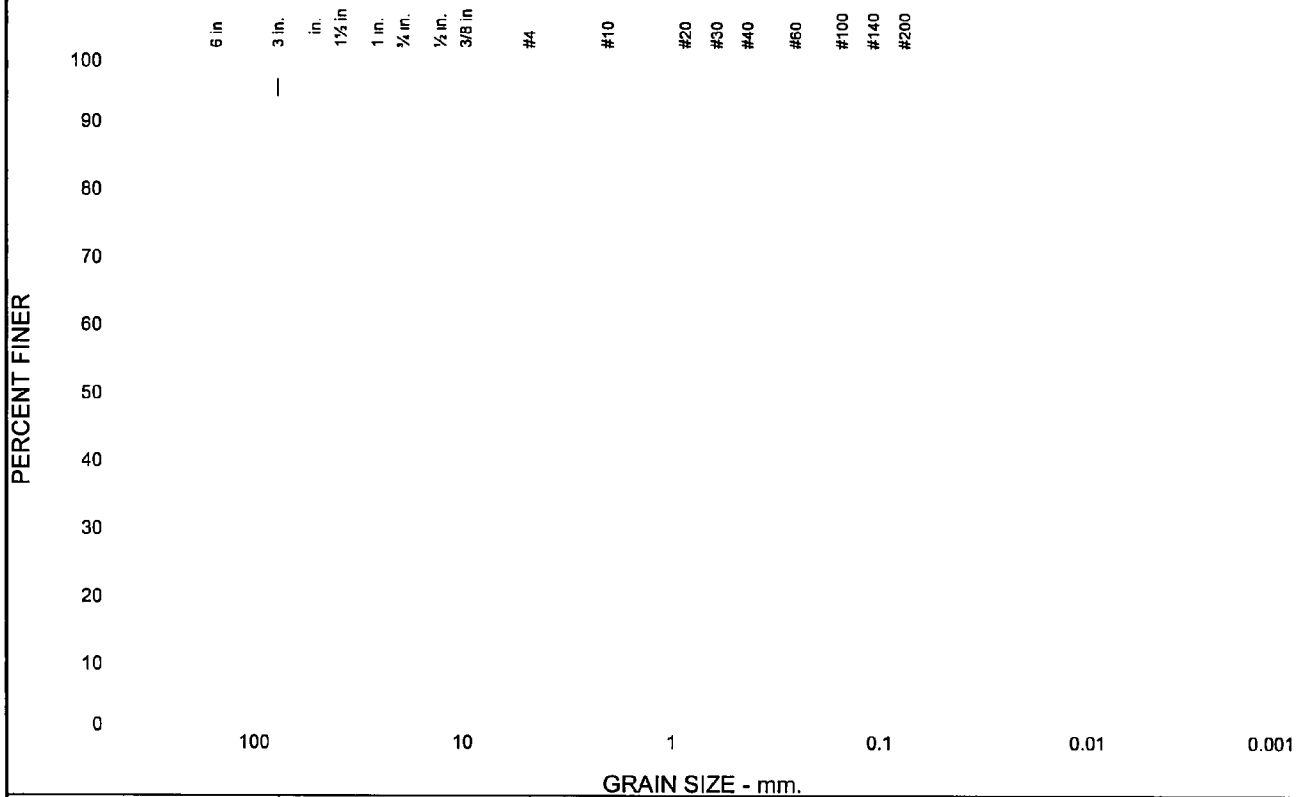

% +3"	% Gravel		% Sand			% Fines	
	Coarse	Fine	Coarse	Medium	Fine	Silt	Clay
0.0	22.2	33.3	9.9	7.8	14.0	12.8	

SIEVE SIZE	PERCENT FINER	SPEC.* PERCENT	PASS? (X=NO)
2"	100.0		
1 1/2"	97.4		
1"	85.7		
3/4"	77.8		
1/2"	65.3		
3/8"	58.5		
#4	44.5		
#8	36.4		
#10	34.6		
#16	31.3		
#30	28.2		
#40	26.8		
#50	25.2		
#100	21.6		
#200	12.8		

Soil Description

silty gravel with sand (GM)

Atterberg Limits

PL= NP LL= NV PI= NP

Coefficients

D₉₀= 29.0777 D₈₅= 24.7744 D₆₀= 10.2128
D₅₀= 6.4302 D₃₀= 0.8915 D₁₅= 0.0873
D₁₀= C_u= C_c=

Classification

USCS= GM AASHTO= A-1-a

Remarks

RECEIVED 6/16/2015

* (no specification provided)

Location: TEST PIT 1 & 2 COMBINED
Sample Number: 29547

Date: 6/24/2015

	<p>Client: GOLDER ASSOCIATES</p> <p>Project: SPRING MOUNTAIN RACEWAY</p> <p>Project No: 1172</p> <p style="text-align: right;">Figure:</p>
---	--

Tested By: M. PONTONI **Checked By:** S. VINEIS

Particle Size Distribution Report

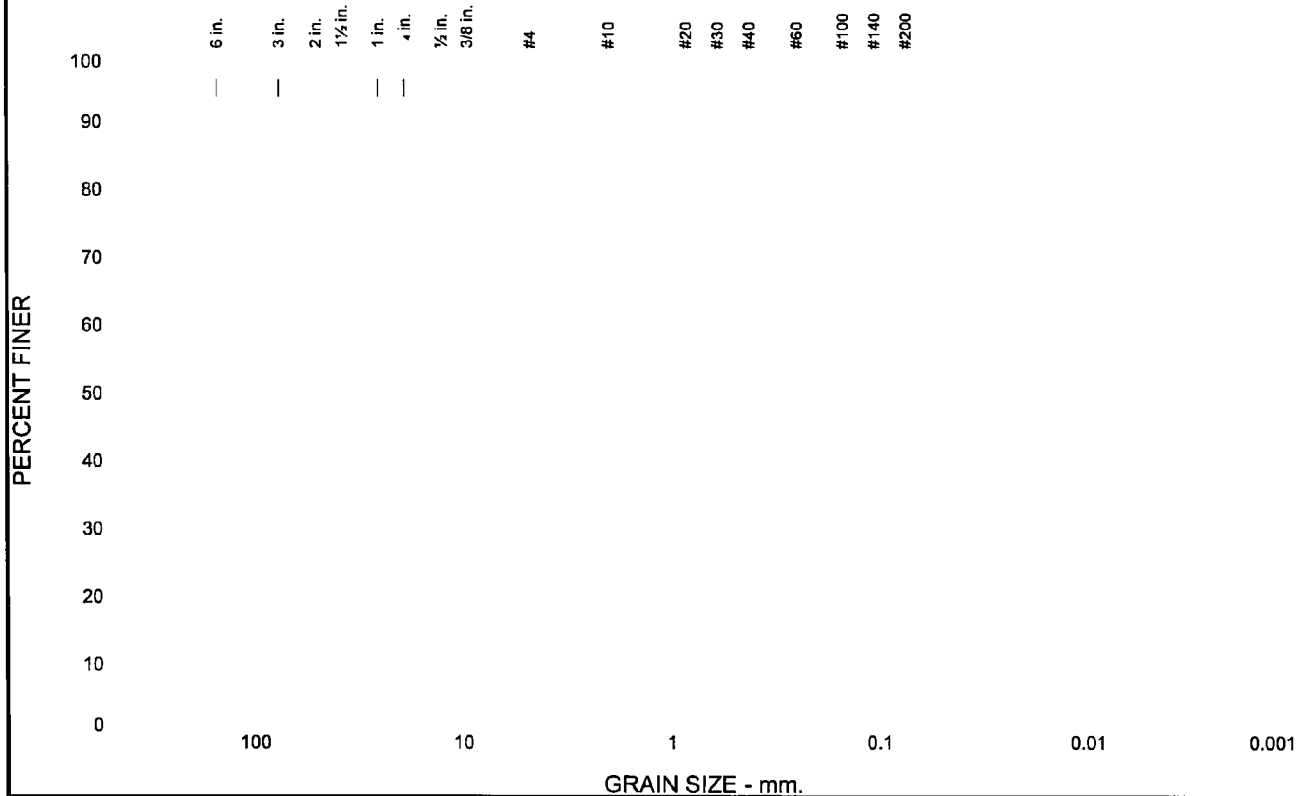

% +3"	% Gravel		% Sand			% Fines	
	Coarse	Fine	Coarse	Medium	Fine	Silt	Clay
0.0	0.0	12.7	3.3	1.9	14.8	67.3	

SIEVE SIZE	PERCENT FINER	SPEC.* PERCENT	PASS? (X=NO)
3/4"	100.0		
1/2"	95.0		
3/8"	92.1		
#4	87.3		
#8	84.6		
#10	84.0		
#16	83.1		
#30	82.4		
#40	82.1		
#50	81.6		
#100	78.9		
#200	67.3		

Soil Description

sandy lean clay (CL)

Atterberg Limits

PL= 22 LL= 37 PI= 15

Coefficients

D₉₀= 7.3587 D₈₅= 2.6512 D₆₀=
D₅₀= D₃₀= D₁₅=
D₁₀= C_u= C_c=

Classification

USCS= CL AASHTO= A-6(9)

Remarks

RECEIVED 6/16/2015

* (no specification provided)

Location: BORING 01 AT 100.0'-101.5'
Sample Number: 29547

Date: 6/24/2015

	CTION LS RS, INC.	Client: GOLDER ASSOCIATES Project: SPRING MOUNTAIN RACEWAY Project No: 1172	Figure:
--	----------------------------------	--	----------------

Tested By: M. PONTONI **Checked By:** S. VINEIS

**ATTACHMENT 3
DOUBLE RING INFILTRATION TEST FIELD DATA**



CALCULATIONS

Date: 6/12/2015 **Made by:** SAN
Project No.: 1520359 **Checked by:** RR
Subject: Double Ring Infiltration Test **Reviewed by:**
Project Short Title: Spring Mountain Raceway

Location: TP-01 at 5 ft

Constants	Area (in ²)	Depth of Liquid (in)
Inner Ring	113.04	7.00
Annular Space	284.37	7.00

Presoak (Inner Ring)	30 min	60 min	Change at 60 min
Start Depth (in)	7	7	4.6
End Depth (in)	1.2	2.4	

*if change 2-in or more measure 10-minute intervals
if change < 2-in measure at 30-minute intervals

Material: Well Graded Gravel w/ Silt and Sand, Sub-rounded to rounded gravel to >3 in. Cobbles to 12 in. Medium dense to dense

Trial No.		Elapsed Time (total min)	Flow Readings				Liquid Temp	Incremental Infil. Rate		Comments
			Inner Reading		Annular Space			Inner	Annular	
			Reading (in)	Flow (in ³ /hr)	Reading (in)	Flow (in ³ /hr)				
1	S	0	7	847.80	7	2559.30	84	7.50	9.00	Refill
	E	10	5.75		5.5					
2	S	10	5.75	1390.39	5.5	5118.59	84	12.30	18.00	
	E	20	3.7		2.5					
3	S	20	7.5	1356.48	7.5	5630.45	85	12.00	19.80	Refill
	E	30	5.5		4.2					
4	S	30	8	1492.13	8	5971.69	85	13.20	21.00	Refill
	E	40	5.8		4.5					
5	S	40	8	1526.04	8	6483.55	85	13.50	22.80	Refill
	E	50	5.75		4.2					
6	S	50	8	1526.04	8	5801.07	85	13.50	20.40	Refill
	E	60	5.75		4.6					
7	S	60	8	1492.13	8	6142.31	85	13.20	21.60	Refill
	E	70	5.8		4.4					
8	S	70	8	1526.04	8	6312.93	85	13.50	22.20	Refill
	E	80	5.75		4.3					
9	S									
	E									
10	S									
	E									

**Incremental Infiltration rate= Flow/(ring area*time interval) (ASTM D3385-09)



CALCULATIONS

Date: 6/12/2015 **Made by:** SAN
Project No.: 1520359 **Checked by:** RR
Subject: Double Ring Infiltration Test **Reviewed by:**
Project Short Title: Spring Mountain Raceway

Location: TP-01 at 10 ft

Constants	Area (in ²)	Depth of Liquid (in)
Inner Ring	113.04	7
Annular Space	284.366	7

Presoak (Inner Ring)	30 min	60 min	Change at 60 min
Start Depth (in)	6.9	6.5	0.5
End Depth (in)	6.5	6	

*if change 2-in or more measure 10-minute intervals
if change < 2-in measure at 30-minute intervals

Material: Sandy Silt/Lean Clay with Gravel. Gravel to 1.5 in. Very dense. Local lens not seen on opposite side of excavation.

Trial No.		Elapsed Time (total min)	Flow Readings				Liquid Temp	Incremental Infil. Rate		Comments
			Inner Reading		Annular Space			Inner	Annular	
			Reading	Flow (in ³)	Reading	Flow (in ³)				
1	S	0	7		7		84			Refill
	E	30	6.75	28.26	6.6	113.7465	84	0.5	0.8	
2	S	30	6.75		6.6		84			
	E	60	6.5	28.26	5.8	227.493	84	0.5	1.6	
3	S	60	6.5		5.8		85			
	E	90	6.25	28.26	5.3	142.1831	85	0.5	1	
4	S	90	6.25		5.3		85			
	E	120	6	28.26	4.8	142.1831	85	0.5	1	End of test
5	S									
	E									
6	S									
	E									
7	S									
	E									
8	S									
	E									
9	S									
	E									
10	S									
	E									
11	S									

**Incremental Infiltration rate= Flow/(ring area*time interval) (ASTM D3385-09)



CALCULATIONS

Date: 6/12/2015 **Made by:** SAN
Project No.: 1520359 **Checked by:** RR
Subject: Double Ring Infiltration Test **Reviewed by:**
Project Short Title: Spring Mountain Raceway

Location: TP-02 at 10 ft

Constants	Area (in ²)	Depth of Liquid (in)
Inner Ring	113.04	9
Annular Space	284.366	9

Presoak (Inner Ring)	30 min	60 min	Change at 60 min
Start Depth (in)	9	9	2.2
End Depth (in)	6.75	6.8	

*if change 2-in or more measure 10-minute intervals
if change < 2-in measure at 30-minute intervals

Material: Well Graded Gravel w/ Silt and Sand, Sub-rounded to rounded gravel to >3 in. Cobbles to 12 in

Trial No.		Elapsed Time (total min)	Flow Readings				Liquid Temp	Incremental Infil. Rate		Comments
			Inner Reading		Annular Space			Inner	Annular	
			Reading	Flow (in ³)	Reading	Flow (in ³)				
1	S	0	9		9		86			Refill
	E	10	8.25	84.78	8.25	213.2747	86	4.5	4.5	
2	S	10	9		9		86			Refill
	E	20	8.25	84.78	8.75	71.09156	86	4.5	1.5	
3	S	20	9		9		86			Refill
	E	30	8.25	84.78	8.75	71.09156	86	4.5	1.5	
4	S	30	9		9		87			Refill
	E	40	8.25	84.78	8.75	71.09156	87	4.5	1.5	
5	S	40	9		9		87			Refill
	E	50	8.25	84.78	8.5	142.1831	87	4.5	3	
6	S	50	9		9		87			Refill
	E	60	8.25	84.78	8.8	56.87325	87	4.5	1.2	
7	S	60	9		9		87			Refill
	E	70	8.3	79.128	8.8	56.87325	87	4.2	1.2	
8	S	70	9		9		87			Refill
	E	80	8.25	84.78	8.7	85.30988	88	4.5	1.8	
9	S	80	9		9		88			Refill
	E	90	8.25	84.78	8.8	56.87325	88	4.5	1.2	
10	S	90	9		9		88			Refill
	E	100	8.25	84.78	8.8	56.87325	88	4.5	1.2	End of test

**Incremental Infiltration rate= Flow/(ring area*time interval) (ASTM D3385-09)



CALCULATIONS

Date:	6/11/2015	Made by:	SAN
Project No.:	1520359	Checked by:	RR
Subject:	Double Ring Infiltration Test	Reviewed by:	
Project Short Title:	Spring Mountain Raceway		

Location: TP-02 at 15 ft

Constants	Area (in ²)	Depth of Liquid (in)
Inner Ring	113.04	9
Annular Space	284.366	9

Presoak (Inner Ring)	30 min	60 min	Change at 60 min
Start Depth (in)	9	9	9
End Depth (in)	0	0	

*if change 2-in or more measure 10-minute intervals
if change < 2-in measure at 30-minute intervals

Material: Well Graded Gravel w/ Silt and Sand, Sub-rounded to rounded gravel to >3 in. Cobbles to 12 in

Trial No.	S	E	Elapsed Time (total min)	Flow Readings				Liquid Temp	Incremental Infil. Rate		Comments
				Inner Reading		Annular Space			Inner	Annular	
				Reading	Flow (in ³)	Reading	Flow (in ³)				
1	S		0	9		8.8		68			Refill
	E		10	4.8	474.768	4.7	1165.902	68	25.2	24.6	
2	S		10	9		8.9		69			Refill
	E		20	4.9	463.464	4.9	1137.465	69	24.6	24	
3	S		20	9		9.1		69			Refill
	E		30	5.3	418.248	5.6	995.2819	69	22.2	21	
4	S		30	9.1		9.3		69			Refill
	E		40	5.5	406.944	5.8	995.2819	69	21.6	21	
5	S		40	8.9		9.1		69			Refill
	E		50	5.4	395.64	5.9	909.972	70	21	19.2	
6	S		50	9.1		9.2		70			Refill
	E		60	5.5	406.944	6	909.972	70	21.6	19.2	
7	S		60	9		9.1		70			Refill
	E		70	5.5	395.64	6	881.5354	70	21	18.6	
8	S		70	9		9.2		70			Refill
	E		80	5.5	395.64	5.5	1052.155	70	21	22.2	End of test
9	S										
	E										
10	S										
	E										

**Incremental Infiltration rate= Flow/(ring area*time interval) (ASTM D3385-09)

APPENDIX C
FAST® PROCESS DESCRIPTION AND CALCULATIONS

FACTORY BUILT FAST®
PAHRUMP, NV
 Isaiah LaRue

← 70.5 ft length total including clarifier →

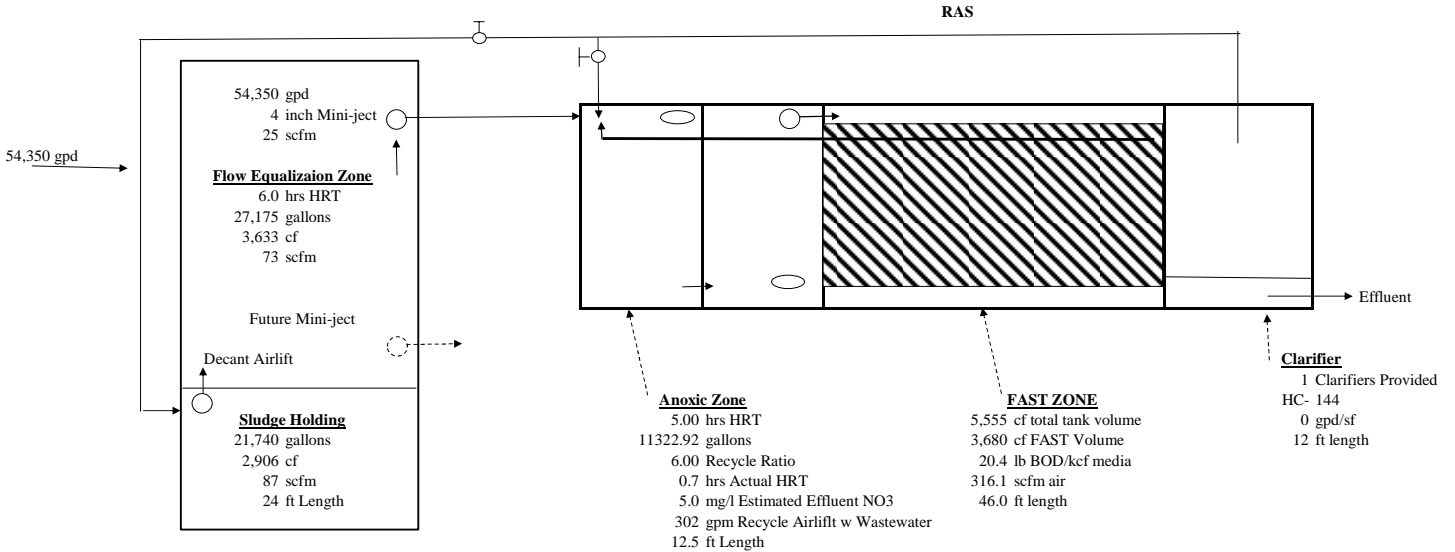

Blowers	
Process Air Flow	478 scfm
Process Blower	20 bhp
FE Air Flow	73 scfm
FE Blower	4 bhp

**SPRING MOUNTAIN MOTORSPORTS RANGE
PAHRUMP, NV
FAST PROCESS DESCRIPTION PHASE 1
April 27, 2015**

Design Influent Characteristics

Q	54,350-gpd	
BOD ₅	250-mg/L	113-lbs BOD/Day
TSS	250-mg/L	113-lbs TSS/Day
TKN	40-mg/L	18-lbs TKN/Day
Temperature	15 Deg C	

Effluent Characteristics

BOD ₅	30-mg/L
TSS	30-mg/L
TN	10-mg/L
pH	6.0 to 9.0 Range

Treatment System Components

The treatment system is to consist of equalization, anoxic to reduce nitrogen, aeration in a FAST® unit, clarifier for settling and removal of solids, and waste sludge storage.

Flow Equalization

For surge capacity, a 3,633-cf equalization tank which provides a 6 hr detention time. This allow the FAST® to operate at a fairly steady flow rate. Air required for mixing the equalization tank is based on 20-scfm/kcf to provide a well mixed tank and ensure the solids will not settle out.

$$\frac{3,633\text{-cf}}{1,000\text{-cf}} \times 20 \text{ scfm/kcf} = 73\text{-scfm}$$

Pre-aeration Anoxic Zone

A HRT of 5-hrs was selected for sizing the total anoxic zone volume. This was chosen based on using a recycle ratio of 6 to 1, which gives an actual retention time in the anoxic zone of 1.15-hrs. The recycle ratio of is expected to produce an effluent nitrate concentration of about 3.5-mg/l with a total effluent nitrogen of less than 7-mg/l.

$$\frac{54,350\text{-gpd} \times 5\text{-hrs}}{24\text{-hrs/day}} = 11,320\text{-gallons or } 1,514\text{-cf total anoxic volume}$$

Using a Recycle Ratio of 6 calculate the actual HRT including the influent flow and the recycle flow.

$$\begin{aligned} \text{Actual HRT} &= \frac{\text{Number Gallons in Anoxic Tank}}{\text{Influent Flow, gpd} / 24 \text{ gal/hr} + \text{Influent Flow} \times \text{Recycle Ratio}} = \\ &= \frac{11,323\text{-gal}}{54,350\text{-gpd}/24 \text{ gal/h} + 54,350\text{-gpd}/24 \text{ gal/h} \times 6} = 0.71 \text{ hrs HRT} \end{aligned}$$

The total anoxic volume is divided into 2 zones to provide more efficient removal of the nitrate. Mixers are used in each anoxic zone to maintain the suspension of the biological solids and provide good contact with the nitrate.

$$\text{Estimated Effluent Nitrogen} = \frac{40\text{-mg/l Influent TKN}}{6 \text{ Recycle Ratio} + 2} = 5.0 \text{ mg/l Effluent Nitrogen}$$

The effluent will carry some non-biodegradable TKN out in the effluent some where typically in the range of 1 to 3 mg/l. Thus the effluent nitrogen will meet the discharge limit of 10 mg/l or less.

Thus, with an effluent TKN less than 5-mg/L, the effluent TN should be consistently less than 7-mg/l

A recycle pump is used to transport the nitrates from the end of the anoxic zone into the head of the FAST zone. An pipe is then used to move the effluent from the FAST zone back to the head of the anoxic zone.

$$\text{Size of Recycle pump} = \frac{54,350\text{-gpd} \times 6 \text{ Recycle Ratio}}{1,440\text{-min/day}} + \frac{2 \times 54,350\text{-gpd}}{1,440\text{-min/}} = 302\text{-gpm}$$

Pump shall be sized for a maximum flow rate of 350-gpm flow rate.

FAST® Aeration Zone

The loading on the FAST® unit to provide nitrification is based on a maximum BOD loading of 20-lbs/d/kcf of media.. The media is sized based on 45 lb/d BOD per 1000 cf media.

$$\frac{113\text{- lbs BOD}}{\text{Day}} \times \frac{1000 \text{ ft}^3 \text{ Media}}{45 \text{ lbs/day}} = 2,510\text{-ft}^3 \text{ of media}$$

Determine if nitrogen is limiting the media size. The loading ratio for 15 Deg C is 0.1605 lb/day/kcf. To be conservative use 0.15 lb/d-kcf media. The media used is 38sf/cf.

$$\frac{18\text{- lbs TKN} \times 1,000 \text{ cf}}{0.15\text{-lb/d/sf media} \times 38\text{-sf/cf media}} = 3,160\text{-cf media}$$

In order to make the media fit the tank it is

The above media provides a 39.8 ft tank length using 10 ft length x 10.5 ft deep media. It is necessary to match the size of the tank. The tank chosen is 46 ft length and the media volume is 3,680-cf.

Clarifier

The estimated loading rate is 135-gpd/sf.

This estimated loading rate provides an area of = 54,350-gpd/135-gpd/sf = 403-sf

Use the HC-144 clarifier with a 144-gpd area. Check the loading rate with the HC-144.

The Actual Loading Rate Using the HC-144 Clarifier = $\frac{54,350\text{-gpd}}{144\text{-sf}} = 377\text{-gpd/sf loading rate}$

Sludge Storage (Construct two sludge storage tanks)

The typical sludge production rate for the FAST treatment system is = 0.60-lbs x lb/d BOD₅

$$\frac{113\text{- lbs BOD} \times 2}{\text{Day}} \times \frac{0.60 \text{ lbs sludge}}{\text{lb BOD}} = \frac{136\text{-lbs sludge}}{\text{day}}$$

It is important to state that the FAST® system produces a dense sludge because of the nature of the solids sloughing off the media. The sludge typically contains a large number of nematodes and other higher forms of life that eat the bacterial solids. Assuming a solids concentration of 1.5% and 20 days storage however it is not uncommon to have a solids concentration of 4 to 6 or more :

$$\frac{136\text{-lbs/day dry sludge}}{(0.03) \times (8.34)} = 544\text{-gpd sludge}$$

$$20 \text{ days} \times \frac{136\text{-Pounds}}{\text{Day}} \times \frac{1}{8.34 \times 1.5/100} = 21,740\text{-gallons or } 2,906\text{-cf}$$

A 3 inch decant airlift is provided to help dewater the sludge and provide additional storage capacity.

Blower

1. The maximum air requirement for BOD removal is based on 1.5 lbs oxygen per lb BOD.

$$\frac{250\text{- mg/l BOD} \times 8.34 \times 54,350\text{-gpd}}{10^6 \text{ gallon/MG}} \times 1.5 = 170\text{-lb/d AOR Oxygen for BOD}$$

$$\text{Calculate SOR lb O}_2\text{/Hr} = \frac{(\text{Total lb O}_2\text{/Day})(\text{loading})(C_s)}{\alpha(\rho \times \beta \times C_{st} - C_{min})C_{tempc} \times 24}$$

where, C_s - O₂ saturation value at 20 °C, 9.2,

α - wastewater effects on transfer coefficient (0.8),

ρ - elevation correction, (1000ft = 0.97),

β - wastewater effects on saturation concentration (0.9),

C_{st} - O₂ saturation value at operating temperature, 8.26 mg/L

C_{min} - minimum dissolved oxygen concentration (2 mg/L),

C_{tempc} - 1.024^{T-20}. (1.126 correction at 25 Deg C)

$$\text{Calculate SOR lb O}_2\text{/Hr} = \frac{(170\text{-lbs/day} \times 9.2)}{0.8(0.97 \times 0.9 \times 8.26 - 2)1.126 \times 24} = 13.8\text{-lb/hr}$$

To determine how much air must be supplied to transfer 1.87 lbs O₂ the diffuser efficiency must be consider

$$\text{scfm} = \frac{13.8\text{- lbs O}_2\text{/hr}}{\text{O}_2 \text{ transfer eff.} \times 0.0176 \text{ lb O}_2\text{/ft}^3 \times 60 \text{ minutes/hr}} = \text{Blower Output Required}$$

The transfer efficiency will be about 4% based on previous experience.

$$\text{Blower for Aeration, scfm} = 13.8/(0.04 \times 0.0176 \times 60) = 318\text{-scfm}$$

2. Sludge Storage air for mixing is provided at a rate of 30 scfm/kcf. Thus the air requirements for the sludge storage tank is:

$$\frac{2,906\text{-ft}^3}{1000 \text{ ft}^3/\text{k cf}} \times 30\text{-scfm/kcf} = 87\text{-scfm}$$

Blower Requirements Summarized:

Two main plant blowers will be provided, one will supply air to the main plant components while the other is a standby blower. Due to the varying water depth in the equalization tank, a separate blower system is used to provide its mixing.

	<u>Flow Equalization</u>	<u>Main Plant</u>
Flow Equalization	73-scfm	
Aeration		318-scfm
Sludge Storage		87-scfm
Recycle Air		50-scfm
<u>MINI-JECT</u>		<u>25-scfm</u>
Total	73 scfm	480-scfm

Operating Conditions

It is important that the wastewater does not contain any toxic or inhibitory materials that will reduce or prevent completely biological growth and metabolism of the wastewater organic material. The following two tables, although not intended to be all inclusive, show some of the materials that have been found to be toxic and/or inhibitory and therefore should not be present in the wastewater. Although this plant is not intended to provide nitrification, materials that are toxic and/or inhibitory to nitrifying organisms are included in these tables in case nitrification becomes an issue in the future.

TABLE I. Inorganic Compounds Causing Inhibition

Pollutant	For BOD Removal mg/L	For Nitrification mg/L
Aluminum	15 - 26	--
Ammonia	480	--
Arsenic	0.1	--
Borate (Boron)	0.05 - 100	--
Cadmium	10 - 100	--
Calcium	2500	--
Chromium (VI)	1 - 10	0.25
Chromium (III)	50	--
Copper	1.0	0.005-0.5
Cyanide	0.1 - 5.0	0.34
Iron	1000	--
Lead	0.1	0.5
Manganese	10	--
Magnesium	--	50
Mercury	0.1 - 5.0	--
Nickel	1.0 - 2.5	0.25
Silver	5	--
Sulfate	--	500
Zinc	0.08 - 10	0.08-0.5

Source: Wastewater Treatment Plant Design, WPCF MOP 8, p227, (1982)

TABLE II.
Organic Compounds
Inhibiting to Nitrifiers

Acetone	2000 mg/L
Aniline	< 1 mg/L
Benzene (1)	13 mg/L
Carbon Disulfide	38 mg/L
Chloroform	18 mg/L
m-Cresol (1)	0.78 mg/L
p-Cresol (1)	27 mg/L
2,4-Dichlorophenol (1)	0.79 mg/L
Ethanol	2400 mg/L
Ethylbenzene (1)	96 mg/L
Ethylenediamine	17 mg/L
Hexamethylene Diamine	85 mg/L
Monoethanolamine	< 200 mg/L
Nitrobenzene (1)	0.92 mg/L
Phenol	5.6 mg/L
Toluene (1)	84 mg/L
Xylene (1)	100 mg/L
Quaternary Ammonia Cpds (2)	<2 mg/L

Source: Nitrogen Control Manual, p94, EPA/625/R-93/010 (1993)

- (1) Research JWPCF, 63, No. 3, p200, (May/June 1991)
- (2) "Impact of cleaning and Disinfecting Agents on Biological Treatment Processes," James C. Young, p14, paper presented at 2001 Industrial Waste Technical Conference, WEF, 8/12-15/01.

APPENDIX D
FAST® TREATMENT PLANT PERFORMANCE DATA

FAST@ DESIGN

Project:

West Bridgewater, MA

April 9, 2009

PM:	Matt Redenbaugh
-----	-----------------

Input Data and Waste Characteristics:

Flow, Maximum	7,175 gpd	
BOD, Maximum	350 mg/l	21 lb/d
	mg/l	0 lb/d
TSS	350 mg/l	21 lb/d
TKN Maximum	65 mg/l	3.9 lb/d
Temp of Wastewater, Minimum	10 Deg C	
Phosphorus as P	mg/l	0.0 lb/d

Required Effluent	Monthly Avg
BOD	30 mg/l
TSS	30 mg/l
TKN	mg/l
NH3 Summer	mg/l
NH3 Winter	mg/l
NO3	mg/l
TN	25 mg/l
Temperature	10 Deg C
Cl2 -- Daily Max	mg/l
Phosphorus as P	mg/l

Note: Customers in this area may use cleaning agents, sanitizers, etc. type products that contain quaternary ammonium compounds and will need to substitute these products with ones that do not contain quaternary ammonium compounds. If any quaternary ammonium compounds are present, the wastewater will not be able to be nitrified because quaternary ammonium compounds are toxic to nitrifying bacteria. As little as 2 mg/l of quaternary ammonium compounds have been shown to totally inhibit nitrification.

West Bridgewater, Massachusetts W. Center St. - Chili's
Smith & Loveless FAST Wastewater Treatment Plant
Performance Data 2/27/2012 to 11/20/2013

TOWN	LOCATION	SAMPLE DATE	SERVICE PROVIDER	TYPE	SAMPLE TYPE	LAB	TEMP	pH	INFLUENT				EFFLUENT							
									BOD	NH3	TKN	TSS	BOD	TSS	NO2	NO3	NH3	TKN	TN	Alkalinity
W. Bridgewater	W. Center St. - Chili's	2/27/2012	WTS	comm	GRAB	AB		7.60	590				4.40	43.00		1.72	ND	6.13	7.85	
W. Bridgewater	W. Center St. - Chili's	3/29/2012	WTS	comm	GRAB	AB		7.60	810				4.40	8.00		1.88	0.87	2.69	4.57	
W. Bridgewater	W. Center St. - Chili's	4/23/2012	WTS	comm	GRAB	AB		7.60	730				<4.0	8.00		2.73	1.46	2.84	5.57	
W. Bridgewater	W. Center St. - Chili's	5/30/2012	WTS	comm	GRAB	AB		7.60	730				4.60	20.00		2.80	0.67	3.94	6.74	
W. Bridgewater	W. Center St. - Chili's	6/29/2012	WTS	comm	GRAB	AB		7.70	460				<4.0	<4.0		1.47	0.48	1.24	2.71	
W. Bridgewater	W. Center St. - Chili's	7/20/2012	WTS	comm	GRAB	AB		7.70	320				<4.0	7.00		0.94	0.35	1.19	2.03	
W. Bridgewater	W. Center St. - Chili's	8/30/2012	WTS	comm	GRAB	AB		7.50	290				<4.0	<4.0		2.82	0.54	1.60	4.42	
W. Bridgewater	W. Center St. - Chili's	9/26/2012	WTS	comm	GRAB	AB		7.50	410				<4.0	5.00		2.71	0.34	1.42	4.13	
W. Bridgewater	W. Center St. - Chili's	10/31/2012	WTS	comm	GRAB	AB		7.50	410				4.50	10.00		1.61	1.91	3.72	5.33	
W. Bridgewater	W. Center St. - Chili's	11/30/2012	WTS	comm	GRAB	AB		7.60	330				<4.0	10.00		3.23	0.93	2.50	5.73	
W. Bridgewater	W. Center St. - Chili's	12/27/2012	WTS	comm	GRAB	AB		7.50	440				8.70	14.00		1.93	2.76	5.21	7.14	
W. Bridgewater	W. Center St. - Chili's	1/31/2013	WTS	comm	GRAB	AB		7.60	550				5.60	14.00		1.84	0.41	2.65	4.49	
W. Bridgewater	W. Center St. - Chili's	2/28/2013	WTS	comm	GRAB	AB		7.40	500				<4.0	4.00		0.76	1.92	4.15	4.91	
W. Bridgewater	W. Center St. - Chili's	3/27/2013	WTS	comm	GRAB	AB		7.50	780				4.80	10.50		1.17	1.02	3.49	4.66	
W. Bridgewater	W. Center St. - Chili's	4/30/2013	WTS	comm	GRAB	AB		7.40	420				7.00	9.00		1.07	2.79	4.89	5.96	
W. Bridgewater	W. Center St. - Chili's	5/31/2013	WTS	comm	GRAB	AB		7.20	480				8.80	23.50		3.78	0.81	4.15	7.93	
W. Bridgewater	W. Center St. - Chili's	6/28/2013	WTS	comm	GRAB	AB		7.20	720				<4.0	4.00		2.52	0.66	1.86	4.38	
W. Bridgewater	W. Center St. - Chili's	7/31/2013	WTS	comm	GRAB	AB		7.40	510				<4.0	6.00		3.27	1.32	2.44	5.71	
W. Bridgewater	W. Center St. - Chili's	9/3/2013	WTS	comm	GRAB	AB		7.30	530				6.50	13.60		1.65	2.12	4.68	6.33	
W. Bridgewater	W. Center St. - Chili's	9/30/2013	WTS	comm	GRAB	AB		7.30	370				7.70	21.50		0.64	1.03	3.66	4.30	
W. Bridgewater	W. Center St. - Chili's	11/5/2013	WTS	comm	GRAB	AB		7.30	990				<4.0	<4.0		2.14	0.77	1.05	3.19	
W. Bridgewater	W. Center St. - Chili's	11/20/2013	WTS	comm	GRAB	AB		6.40	720				<4.0	<4.0		0.23	0.13	ND	ND	

Service Providers

WTS Wastewater Treatment Services

Labs

AB Analytical Balance

Average	550	6	13	2	1	3	5
Average without the < values or the ND.							

**APPENDIX E
TECHNICAL SPECIFICATIONS**



Table of Contents

Specification Number	Specification Title	Revision	DATE
01010	Summary of Work	0	May 2016
01025	Measurement and Payment	0	May 2016
01035	Modifications Procedure	0	May 2016
01041	Project Coordination	0	May 2016
01050	Field Engineering	0	May 2016
01091	Reference Standards	0	May 2016
01092	Abbreviations	0	May 2016
01200	Project Meetings	0	May 2016
01300	Contractor Submittals	0	May 2016
01400	Quality Control	0	May 2016
01505	Mobilization	0	May 2016
01515	Temporary Utilities	0	May 2016
01530	Protection of Utilities	0	May 2016
01535	Safety	0	May 2016
01550	Access Roads and Parking	0	May 2016
01560	Temporary Environmental Controls	0	May 2016
01600	Materials and Equipment	0	May 2016
01630	Options and Substitutions	0	May 2016
01710	Cleaning	0	May 2016
01730	Operation and Maintenance Data	0	May 2016
01740	Warranties	0	May 2016
02200	Earthworks	0	May 2016
02225	Trench Excavation and Backfill	0	May 2016
02401	Sanitary Sewer Pipe	0	May 2016
02601	Manholes	0	May 2016
02621	General Piping System and Appurtenances	0	May 2016
02625	Pressure Pipe – Valves and Fittings	0	May 2016
02670	Valves	0	May 2016
03150	Formwork for Cast-in-Place Concrete	0	May 2016
03200	Reinforcing Steel	0	May 2016
03300	Cast-in-Place Concrete	0	May 2016
03470	Precast Vaults	0	May 2016
11312	Self-Priming Effluent Pump	0	May 2016
11390	Package Wastewater Treatment	0	May 2016

SECTION 01010

SUMMARY OF WORK

PART 1 GENERAL

1.01 SUMMARY

- A. Construction of a wastewater treatment plant site for a new development, including package treatment plant equipment (Smith and Loveless FAST system), earthwork for site improvements and Rapid Infiltration Basins (RIBs), yard piping, asphalt concrete and earthen surfacing, blower and control building, perimeter berm and block wall, entrance gate and ancillary work and appurtenances required for a complete installation. Tie-in of the new force main for the proposed lift station (detailed in separate design report). The plant work include installation of all Owner purchased equipment.
- B. Furnish tools, equipment, materials, supplies, and manufactured articles; furnish transportation and services including fuel, power, water, and essential communications; and perform labor, work, or other operations required in accordance with the Construction Documents.
- C. The Work shall be complete, and all work, materials, and services not expressly shown or called for in the Construction Documents which may be necessary for the complete and proper construction of the Work in good faith shall be performed, furnished, and installed by Contractor as though originally so specified or shown, at no increase in cost to Owner.

1.02 STREAMLINED SPECIFICATIONS

- A. These specifications are written in the streamlined or declarative style utilizing incomplete sentences.
- B. Omissions of such words and phrases as "The Contractor shall." "in conformity therewith," "shall be," "as shown on the Drawings," "a", "an," "the," and "all" are intentional in streamlined sections.
 - 1. Omitted words shall be supplied by inference in the same manner as when a note appears on the drawings.
 - 2. The omission of such words shall not relieve the Contractor from providing all items and work described herein or indicated on the drawings.

1.03 CONTRACT METHOD

- A. The work hereunder will be constructed under a single Lump Sum Contract.

1.04 WORK BY OTHERS

- A. Work may be conducted at or near the site by other contractors during the performance of the Work under this Contract.

- B. Conduct operations to cause a minimum of interference with work of other contractors and cooperate fully with other contractors.
- C. Interference with Work on Utilities:
 - 1. Cooperate fully with utility forces of Owner or forces of public or private agencies engaged in relocating, altering, or otherwise rearranging of facilities which interfere with the progress of the Work.
 - 2. Schedule the Work to minimize interference with relocating, altering, or other rearranging of facilities.

1.05 CONTRACTOR'S USE OF PROJECT SITE

- A. Contractor's use of project site shall be limited to construction operations, including onsite storage of materials, onsite fabrication facilities, and field offices.
- B. Limit use of site to areas defined by Owner and/or construction limits.
 - 1. Limit use of premises for work and storage to allow for work of other contractors and subcontractors.
 - 2. Notify Owner of any work necessary to complete the Work is outside the construction limits shown.
- C. Owner will have complete control over the use of the site by Contractor. Discuss intended use of site with Owner before starting work.
- D. Assume full responsibility for the protection and safe keeping of products stored on the site.
- E. Move stored products as directed by the Engineer which interfere with operations of Owner or separate contractors.
- F. Obtain and pay for the use of additional storage and work areas needed for operations.

1.06 PERMITS

- A. Obtain all permits required for construction, not already obtained by the Owner.
- B. Pay the required fees and acquire all permits required for the construction of the project.

1.07 WORK SEQUENCE

- A. Schedule activities to accommodate the overall construction schedule of Owner and coordinate the detailed schedule with Owner.
- B. Perform work in an expeditious manner to ensure completion at the earliest possible date, but in no case later than the completion dates to be made available to Contractor by Owner.

- C. A construction schedule will be developed by the contractor and will be submitted for review to the owner.

1.08 COMPLETION OF THE WORK

- A. For Contract purposes, the completion date of the Contract will be deemed to be the date of final completion of the project, including specially scheduled items.

PART 2 PRODUCTS

Not used.

PART 3 EXECUTION

Not used.

END OF SECTION

SECTION 01025

MEASUREMENT AND PAYMENT

PART 1 GENERAL

1.01 SECTION INCLUDES

- A. Lump sum base bid description for Contract.
- B. Measurement criteria applicable to the price schedule.
- C. Defect assessment and non-payment for rejected work

1.02 AUTHORITY

- A. Take all measurements and compute quantities. Owner will verify measurement and quantities.
- B. Assist by providing necessary equipment, workers, and survey personnel as required.

1.03 UNIT QUANTITIES SPECIFIED

- A. Quantities indicated on the Plans are for bidding and contract purposes only. Quantities and measurements supplied or placed in the Work and verified by the Owner determine basis for estimated monthly pay requests only and are not the basis for changes to the total lump sum price.
- B. If the actual Work requires more or fewer quantities than those quantities indicated on the Plans, provide the required quantities with no change in the lump sum price, unless those quantities change as a result of a change in the scope of work after award of the Contract.
- C. If the actual Work requires a 25 percent or greater change in quantity less than or more than any quantity indicated, Owner or Contractor may claim for a Contract Price adjustment.

1.04 MEASUREMENT OF QUANTITIES

- A. Measurement Devices:
 - 1. Weight Scales: Inspected, tested, and certified by the applicable agency Weights and Measures department within the past year.
 - 2. Platform Scales: Of sufficient size and capacity to accommodate the conveying vehicle.
 - 3. Metering Devices: Inspected tested and certified by the applicable agency department within the past year.
- B. Measurement by Volume: Measured by cubic dimension using mean length, Width, and height or thickness.

- C. Measurement by Area: Measured by square dimension using mean length and width or radius.
- D. Linear Measurement: Measured by linear dimension, at the item centerline or mean chord.
- E. Stipulated Price Measurement: Items measured by weight, volume, area, or linear means or combination, as appropriate, as a completed item or unit of the Work.

1.05 PROGRESS PAYMENTS

- A. Payments for materials, machinery or equipment not incorporated into the Work, but delivered and suitably stored at the site, shall only be made where permitted by, and in accordance with, the terms and conditions of the Contract Documents.
 - 1. Title to materials, machinery, and equipment delivered and suitably stored at the site shall immediately vest in and become the sole property of the Owner upon delivery to the site.
 - 2. Notwithstanding such transfer of title, the Contractor shall have the full continuing responsibility to install, protect, and maintain the products in proper condition and promptly repair, replace and make good damage thereto without cost to the Owner until the Work is fully accepted by the Owner.
 - 3. Transfer of title shall in no way affect Contractor's obligations under the Contract.
- B. Where the Contract Documents permit payment for materials stored off the jobsite. Owner shall have discretion either to approve or disapprove payments for such materials, and Contractor shall, in addition to the other requisites of the Contract Documents, make any provisions necessary, including insurance covering loss or damage to the material, to insure and protect Owner's title and right of possession and access to any such materials for which payment is approved by Owner.
- C. Payments otherwise due, may be withheld by Owner because of defective work not remedied, claims filed, reasonable evidence indicating probability of filing of claims, failure of Contractor to make payments properly to its subcontractors or for materials, machinery, fuel or labor, or applicable taxes, fees and fringe benefits or reasonable doubt that the Contract can be completed for the balance then unpaid, or for any other breach of this Contract or for any other causes specified in the Contract Documents.
 - 1. If the causes are not removed, on written notice, Owner may rectify the same at Contractor's expense.
 - 2. Owner may offset against any sums due Contractor, the amount of any liquidated or unliquidated obligations of Contractor to Owner, whether or not arising out of this Contract.
- D. No payment to Contractor shall operate as an approval of Contractor's work or material, or any part thereof, or to release Contractor from obligations under this Contract.
- E. Format of Payment Applications:

1. Contractor's electronic media driven form including continuation sheets when required.
2. For each item, provide a column for listing each of the following:
 - a. Item Number.
 - b. Description of Work
 - c. Scheduled Values.
 - d. Previous Applications.
 - e. Work in Place and Stored Materials under this Application.
 - f. Authorized Change Orders.
 - g. Total Completed and Stored to Date of Application.
 - h. Percentage of Completion.
 - i. Balance to Finish.
 - j. Retainage.

F. Preparation of Applications:

1. Present required information on electronic media printout.
2. Execute certification by signature of authorized officer.
3. Use data from approved Schedule of Values. Provide dollar value in each column for each line item for portion of work performed and for stored Products.
4. List each authorized Change Order, including number and dollar amount as for an original item of work.
5. Prepare Application for Final Payment.

G. Submittal Procedures:

1. Submit three copies of each Application for Payment.
2. Submit an updated Construction schedule with each Application for Payment.
3. Payment Period: Submit at intervals stipulated in the Agreement.
4. Submit with transmittal letter as specified for Submittals in Section 01300.
5. Submit Owner required waivers.

H. Substantiating Data:

1. When Engineer requires substantiating information, submit data justifying dollar amounts in question.
2. Provide one copy of data with cover letter for each copy of submittal. Show application number and date, and line item by number and description.

1.06 PAYMENT

- A. Payment includes: Full compensation for all required labor, materials, tools, equipment, plant, transportation, services, and incidentals; excavation, removal, erection, application, or installation of an item of Work; overhead and profits.
- B. Final payment for Work governed by unit prices will be made on the basis of the actual measurements and quantities accepted by the Owner multiplied by the unit price for Work which is incorporated in or made necessary by the Work.

1.07 DEFECT ASSESSMENT

- A. Replace the Work, or portions of the Work, not conforming to specified requirements.
- B. If, in the opinion of Owner's Representative, it is not practical to remove and replace the Work, Owner will direct one of the following remedies:
 - 1. The defective Work may remain, but the unit price will be adjusted to a new price at the discretion of the Owner.
 - 2. The defective Work will be partially repaired to the instructions of the Owner's Representative and Owner, and the unit price will be adjusted to a new price at the discretion of the Owner.
- C. The authority of Owner to assess the defect and identify payment adjustment is final.

1.08 LUMP SUM BASE BID

- A. The Lump Sum Base Bid is the total lump sum cost for the base bid items, including all labor, materials, and equipment for the scope of work described in Section 01010, Summary of Work.
- B. Lump sum price also includes all bonds, insurance, and surety.
- C. Contractor agrees to meet all schedules set forth for in this project.

PART 2 PRODUCTS

Not used.

PART 3 EXECUTION

Not used.

END OF SECTION

SECTION 01035

MODIFICATIONS PROCEDURE

PART 1 GENERAL

1.01 SUMMARY

- A. The Work to be performed may be modified by changes required by Owner and the Contract Amount and/or the Contract Time set forth in the Agreement will be adjusted by written Change Order in accordance with this section.
- B. No alterations, increases or decreases shall be made in the Work as shown and specified except on the written order of Owner, and when so made, the value of the Work or materials added or omitted shall be computed and determined by Contractor, subject to the written approval and acceptance by Owner, and the Amount so determined shall be added to or deducted from the Contract Amount.
 - 1. Contractor shall have no claim for additional Work or changed work unless such Work has been done in pursuance of a written order from Owner.
 - 2. Extra Work performed without written order will be at Contractor's expense.

1.02 FIELD ORDERS

- A. Owner and Owner's Representative will have authority to order minor changes in the Work not involving an adjustment in the Contract Amount or Time and not inconsistent with the intent of the Construction Documents.
 - 1. Changes shall be effected by written order and shall be binding on Contractor.
 - 2. Contractor shall carry out written order promptly.

1.03 CHANGE ORDER PROCEDURES

- A. If a change in the Work is desired, Owner will notify Contractor and provide a written description, in the form of drawings or otherwise, of the desired change.
- B. Contractor shall submit to Owner, a firm proposal for any changes in the Contract Amount and/or Time resulting from the proposed change within five days after receipt of the proposed change and shall submit the actual Change Order Request within ten days.
- C. Owner shall have thirty days, or such other time as may be agreed upon, in which to accept or reject Contractor's proposal after its submission, and Contractor shall not modify or withdraw the proposal during this period.
- D. The cost or credit to Owner resulting from a change in Contractor's work shall be determined in one of the following ways:

1. By mutually agreed lump sum properly itemized and supported by sufficient substantiating data to permit evaluation in accordance with the Construction Documents (which may be evidenced by Owner's issuance to Contractor of a Change Order for Contractor's firm proposal as described above);
 2. By unit prices stated in the Construction Documents or subsequently agreed upon; or
 3. On the basis of reasonable costs and savings of those performing the Work attributable to the change; provided, however, that in no case shall contractor's firm proposal described above nor any other method for determining the amount of the change include any cost for:
 - a. Materials, labor, machinery, fuel or other expenses not specifically reimbursable as identified in the article, Cost Limitations, below, or
 - b. Allowance for overhead and profit in excess of ten percent.
- E. Contractor shall, provided a written order signed by Owner is received, promptly proceed with the Work involved.
- F. In the event Owner directs Contractor to perform change in the Work by a written order other than a signed Change Order and without agreeing to the Contractor's firm proposal, then Contractor shall proceed to perform the change and the amount of the change shall be determined either under D,2 above (to the extent unit prices may be applied to the Work involved) or under D,3 above, as Owner may elect in its sole discretion, unless a mutually acceptable lump Sum price is subsequently agreed upon.
1. To the extent Owner elects D,2, the unit price shall be as described in the Contract Documents.
 2. To the extent that D,1 or D,3 is elected, the cost of the Work and any savings shall be determined in accordance with Cost Limitations article, below.
- G. In the event of additional Work ordered by Owner, Contractor shall submit labor and time card sheets, with description of the Work and materials supplied, to the Owner's Representative daily. This document shall govern in determining the workers' time and equipment usage involved in time-and-material-based charges, unless later found to be incorrect.
- H. If Owner or Engineers disputes the validity or amount of a Change Order Request submitted by Contractor but Owner nevertheless directs Contractor to proceed, Contractor shall promptly proceed with the Work under the Change Order pending resolution of the dispute and expeditiously complete such work.
- I. If Contractor wishes to make any other claim for an increase in the Contract Amount, Contractor shall give Owner written notice thereof within twenty days after the occurrence of the event giving rise to such claim, but nothing contained herein shall be deemed to permit Contractor to claim damages on account of delays in Contractor's performance of the Work or interference therewith, it being agreed that Contractor's sole remedy shall be to obtain an extension of time as provided in the Construction Documents.

1.04 COST LIMITATIONS

A. Cost shall be limited to the following:

1. Cost of materials, including sales tax and cost of delivery;
2. Cost of labor, including social security, old age and unemployment insurance, and fringe benefits required by agreement or custom;
3. Workers' compensation insurance;
4. Bond premiums;
5. Rental value of equipment and machinery;
6. Additional costs of supervision and field office personnel directly attributable to the change.

B. When both additions and credits covering related Work or substitutions are involved in a change, the allowance for overhead and profit shall be figured on the basis of the net increase, if any, with respect to such change.

1.05 CHANGE ORDER REQUEST

A. Change Order Request shall consist of the detailed cost estimate outlining the changes in the Work and detailed documentation justifying proposed changes in time.

1. Compute estimate in accordance with accepted estimating procedures and in accordance with the terms of the Construction Documents.
 - a. Costs for labor, machinery, fuel and materials shall be at prevailing rates or wage scales pertinent to the project.
2. Unless otherwise provided in the Construction Documents, labor costs shall mean wages paid for labor under prevailing wage rates, or under a salary and wage scale agreed upon by Owner and Contractor, and shall include welfare and other benefits, if any, as may be payable with respect thereto in accordance with any applicable salary and wage scale.

PART 2 PART 2 - PRODUCTS

Not used.

PART 3 PART 3 – EXECUTION

Not used.

END OF SECTION

SECTION 01041

PROJECT COORDINATION

PART 1 GENERAL

1.01 SECTION INCLUDES

- A. Coordination.
- B. Examination.
- C. Preparation.

1.02 COORDINATION

- A. Coordinate scheduling submittals, and Work of the various sections of the construction specifications to assure efficient and orderly sequence of interdependent construction elements.
- B. Coordinate space requirements and installations. Utilize spaces efficiently to maximize accessibility.
- C. Coordinate completion and clean up of Work of separate sections in preparation for Substantial Completion.
- D. After Owner occupancy of premises, coordinate access to site for correction of defective Work and Work not in accordance with Construction Documents, to minimize disruption of Owner's activities.

PART 2 PRODUCTS

Not used.

PART 3 EXECUTION

3.01 EXAMINATION

- A. Verify that existing site conditions are acceptable for subsequent Work. Beginning Work means acceptance of existing conditions.
- B. Examine and verify specific conditions described in individual specification sections.
- C. Verify that utility services are correctly located.

END OF SECTION

SECTION 01050

FIELD ENGINEERING

PART 1 GENERAL

1.01 WORK INCLUDED

- A. This Section specifies the layout and establishment of field boundaries and grades, lines, and elevations for the Work.

1.02 OWNER FURNISHED STAKES

- A. Owner will provide construction stakes establishing lines and grades for the Work, as follows:
 - 1. One permanent benchmark in the vicinity of the Project site.
 - 2. Stakes at 50 foot intervals for piping, and at structures; stakes placed along offset lines chosen by Contractor.
 - 3. Two stakes, containing horizontal and vertical control, at each structure location.
 - 4. Stakes not delineated above which Engineer may determine are necessary to complete the Work
- B. The above construction stakes shall constitute the field control by and in accordance with which Contractor shall execute the Work, and will be furnished at no expense to Contractor.

1.03 CONTRACTOR FURNISHED STAKES

- A. Engineer will set stakes in addition to those delineated above, if required and requested by Contractor; however, costs for setting additional stakes shall be paid for by Contractor, or will be deducted from any amounts due or to become due to Contractor.
- B. After stakes and marks have been set, it shall be responsibility of Contractor to protect the stakes.
- C. Should any of the stakes be disturbed by Contractor's operations, the costs for replacing stakes and marks shall be paid for by Contractor, or will be deducted from amounts to become due Contractor.

PART 2 PRODUCTS

Not used.

PART 3 EXECUTION

3.01 EXAMINATION

- A. Verify locations of survey control points prior to starting work.
- B. Promptly notify Engineer of any discrepancies discovered.

END OF SECTION

SECTION 01091

REFERENCE STANDARDS

PART 1 GENERAL

1.01 TITLES OF SECTIONS

- A. Captions accompanying specification sections are for convenience or reference only and do not form a part of the Construction Documents.

1.02 APPLICABLE PUBLICATIONS

- A. When references are made to published specifications, codes, standards, or other requirements, and no date is specified only the latest specifications standards, or requirements of the respective issuing agencies, which have been published as of the date that the Work is advertised for bids, shall apply; except to the extent that standards or requirements may be in conflict with applicable laws, ordinances, or governing codes.
- B. No requirements specified or shown on Drawings shall be waived because of any provision of, or omission from, standards or requirements.

1.03 SPECIALISTS ASSIGNMENTS

- A. Specification text may require (or imply) that specific work be assigned to specialists or expert entities who must be engaged to perform that work
- B. Such assignments are special requirements over which Contractor has no choice or option.
- C. These requirements shall not be interpreted so as to conflict with enforcement of building codes and similar regulations governing the Work nor to interfere with local union jurisdiction settlements and similar conventions.
- D. Such assignments are intended to establish which party or entity involved in specific unit of work is recognized as "expert" for the indicated construction processes or operations
- E. Final responsibility for fulfillment of Contract requirements remains with Contractor.

1.04 REFERENCE SPECIFICATIONS, CODES, AND STANDARDS

- A. Work specified shall conform to or exceed requirements of applicable codes and applicable requirements of documents listed below to the extent that the provisions of such documents are not in conflict with requirements of these Specifications or applicable codes.
- B. "Building Code" or "UBC" shall mean the Uniform Building Code of the International Conference of Building Officials (ICBO). The latest edition of the code as approved and used by the local agency as of the date of award, as adopted by the agency having jurisdiction, shall apply to the Work herein, including all addenda, modifications, amendments, or other lawful changes thereto.

- C. In case of conflict between codes, reference standards, Drawings and other Construction Documents, the most stringent requirements shall govern.
 - 1. Bring conflicts to the attention of Owner for clarification and directions prior to ordering or providing materials or labor.
 - 2. Bid the most stringent requirements.
- D. Applicable Standard Specifications:
 - 1. Construct the Work in accordance with requirements of the Construction Documents and the referenced portions of those referenced codes, standards, and specifications listed.
 - 2. Wherever references to "Standard Specifications" are made, the contractual, measurement, and payment provisions therein shall not apply.
- E. "UICN Standards" shall mean Utilities, Inc. of Central Nevada Standards and Specifications for Wastewater Collection System Construction, latest edition.
- F. "Standard Specifications" shall mean the most recent edition of the "Standard Specifications for Public Works Construction", Nye County, Nevada, (Orange Book), including all current supplements, addenda, and revisions thereto.
- G. "Standard Drawings" shall mean the most recent edition of the "Standard Details for Public Works Construction, Nye County, Nevada, including all current supplements, addenda, and revisions thereto.
- H. "OHS Regulations for Construction" shall mean Title 29, Part 1926, Construction Safety and Health Regulations. Code of Federal Regulations (OSHA), including changes and amendments thereto.
- I. "OHS Standards" shall mean Title 29, Part 1910, Occupational Safety and Health Standards, Code of Federal Regulations (OSHA), including changes and amendments thereto.

PART 2 PRODUCTS

Not used.

PART 3 EXECUTION

Not used.

END OF SECTION

SECTION 01092

ABBREVIATIONS

PART 1 GENERAL

1.01 SUMMARY

- A. References made to standards, specifications, or other published data of various national, regional, or local organizations, may refer to such organizations by their acronym or abbreviation only.
- B. The following acronyms or abbreviations may appear in these Construction Documents and shall have the meanings indicated.

1.02 ABBREVIATIONS AND ACRONYMS

AAMA	Architectural Aluminum Manufacturer's Association
AASHTO	American Association of the State Highway and Transportation Officials
ACI	American Concrete Institute
AGA	American Gas Association
AGMA	American Gear Manufacturer's Association
AI	The Asphalt Institute
AIA	American Institute of Architects
AISC	American Institute of Steel Construction
AISI	American Iron and Steel Institute
AITC	American Institute of Timber Construction
ANSI	American National Standards Institute, Inc.
APA	American Plywood Association
API	American Petroleum Institute
AEWA	American Public Works Association
ASCE	American Society of Civil Engineers
ASME	American Society of Mechanical Engineers
ASQC	American Society of Quality Control
ASSE	American Society of Sanitary Engineers
ASTM	American Society of Testing and Materials
AWPA	American Wood Preservers Association
APWI	American Wood Preservers Institute
AWS	American Welding Society
AWWA	American Water Works Association
BBC	Basic Building Code, Building Officials and Code Administrators International
CBM	Certified Ballast Manufacturers
CEMA	Conveyors Equipment Manufacturer's Association
CGA	Compressed Gas Association
CLFMI	Chain Link Fence Manufacturer's Institute
CMA	Concrete Masonry Association
CRSI	Concrete Reinforcing Steel Institute
ELA	Electronic Industries Association
ETL	Electrical Test Laboratories
ICBO	International Conference of Building Officials

IEEE	Institute of Electrical and Electronics Engineers
IES	Illuminating Engineering Society
IME	Institute of Makers of Explosives
IP	Institute of Petroleum (London)
IPCEA	Insulated Power Cable Engineers Association
ISA	Instrument Society of America
IOS	International Organization for Standardization
ITE	Institute of Traffic Engineers
MBMA	Metal Building Manufacturer's Association
MPTA	Mechanical Power Transmission Association
NAAM	National Association of Architectural Metal Manufacturer's
NACE	National Association of Corrosion Engineers
NBS	National Bureau of Standards
NEC	National Electrical Code
NEMA	National Electrical Manufacturers's Association
NFPA	National Fire Protection Association
NFPA	National Forest Products Association
NGU	National Lubricating Grease Institute
NWMA	National Woodwork Manufacturer's Association
OSHA	Occupational Safety and Health Administration
PCA	Portland Cement Association
RWMA	Resistance Welder Manufacturer's Association
SAMA	Scientific Apparatus Makers Association
SMA	Screen Manufacturer's Association
SPR	Simplified Practice Recommendation
SSPC	Steel Structures Painting Council
SSPWC	Standard Specifications for Public Works Construction
UBC	Uniform Building Code
UL	Underwriters Laboratories, Inc.
UICN	Utilities Inc. of Central Nevada
WCLIB	West Coast Lumber Inspection Bureau
WCRSI	Western Concrete Reinforcing Steel Institute
WRI	Wire Reinforcement Institute, Inc.

PART 2 PRODUCTS

Not used.

PART 3 EXECUTION

Not used.

END OF SECTION

SECTION 01200

PROJECT MEETINGS

PART 1 GENERAL

1.01 PRECONSTRUCTION CONFERENCE

- A. Prior to commencement of Work at site, a preconstruction conference will be held at a mutually agreed time and place. The conference shall be attended by:
1. Contractor and its superintendent.
 2. Principal subcontractors.
 3. Engineer.
 4. Representatives of owner.
 5. Governmental representatives as appropriate.
 6. Others as requested by Contractor, Owner, or Engineer.
- B. Unless previously submitted to Owner, bring to the conference a tentative schedule for each of the following:
1. Progress.
 2. Procurement
 3. Values for progress payment purposes.
 4. Shop Drawings and other submittals.
- C. The purpose of the conference is to designate responsible personnel and establish a working relationship. Matters requiring coordination will be discussed and procedures for handling such matters will be established. The agenda will include:
1. Contractor's tentative schedules.
 2. Transmittal, review and distribution of Contractor's submittals.
 3. Processing applications for payment.
 4. Maintaining record documents.
 5. Critical work sequencing.
 6. Field decisions and Change Orders.

7. Use of premises, office and storage areas, security, housekeeping, and Owner's needs.
 8. Major equipment deliveries and priorities.
 9. Contractor's assignments for safety and first aid.
- D. Engineer will preside at the pre construction conference and will arrange for keeping the minutes and distributing the minutes to all persons in attendance.

1.02 PROGRESS MEETINGS

- A. Schedule and administer regular onsite progress meetings at least weekly and at other times as required by Owner or as required by progress of the Work.
- B. Make arrangements for meetings, prepare agenda with copies for participants who preside at meetings.
- C. Contractor and all subcontractors active on the site shall be represented at each meeting. Contractor may request attendance by representatives of suppliers, manufacturers and other subcontractors as appropriate to agenda topics for each meeting.
- D. Owner's Representative will preside at the meetings, record minutes and distribute copies to participants and those affected by decisions made.
- E. Agenda
 1. Review minutes of previous meetings.
 2. Review of Work in progress.
 3. Field observations, problems, and decisions.
 4. Identification of problems which impede planned progress.
 5. Review of submittals schedule and status of submittals.
 6. Maintenance of progress schedule.
 7. Corrective measures to regain projected schedules.
 8. Planned progress during succeeding work period.
 9. Coordination of projected progress.
 10. Maintenance of quality and work standards.
 11. Other business relating to Work.

PART 2 PRODUCTS

Not used.

PART 3 EXECUTION

Not used.

END OF SECTION

SECTION 01300

CONTRACTOR SUBMITTALS

PART 1 GENERAL

1.01 SECTION INCLUDES

- A. Submittal procedures.
- B. Construction progress schedule.
- C. Schedule of Values.
- D. Shop Drawings.
- E. Inspection Certificates.
- F. Spare Parts.
- G. Mix Designs.
- H. Omissions or Errors in Submitted Data.

1.02 SUBMITTAL PROCEDURES

- A. Accompany submittals by transmittal using format bound with Construction Documents or substitute form approved by Engineer. Submittals not accompanied by a form, or where all applicable items on form are not completed, will be returned for resubmittal.
 - 1. Use separate transmittal form for each specific item or class of material or equipment for which a submittal is required.
 - 2. Transmittal of shop drawings for various items using a single transmittal form will be permitted only when the items taken together constitute a manufacturer's "package" or are so functionally related that expedience indicates review of the group or package as a whole.
- B. Sequentially number the transmittal form. Revise submittals with original number and a sequential alphabetic section number, as appropriate.
- C. Identify Project, Contractor, subcontractor or supplier; pertinent drawing and detail number, and specification section number, as appropriate.
- D. Apply Contractor's stamp, signed or initialed certifying that review, verification of Products required field dimensions, adjacent construction Work, and coordination of information is in accordance with requirements of Construction Documents.
- E. Schedule submittals to expedite the Project, and deliver to engineer. Coordinate submission of related items.

- F. For each submittal for review, allow 2 to 4 days excluding delivery time to and from Contractor.
- G. Identify variations from Construction Documents and Product or system limitations which may be detrimental to successful performance of the completed Work.
- H. Provide space for Contractor and Engineer review stamps.
- I. Revise and resubmit, identify all changes made since previous submission.
- J. Distribute copies of reviewed submittals as appropriate. Instruct parties to promptly report any inability to comply with provisions.
- K. Submittals not requested will not be recognized or processed.

1.03 CONSTRUCTION SCHEDULE

- A. Prepare and submit to Owner for approval, a Project Construction Schedule showing proposed sequence to carry out Work within the Contract Time and showing beginning times and completion times for major items of work
- B. Project Construction Schedule:
 - 1. In the form of a time-scaled item-numbered network diagram.
 - 2. Supplement diagram by activity listing used in its preparation and outline, in sufficient detail:
 - a. Proposed operations.
 - b. Interrelationships of the various operations.
 - c. Order of performance so that progress of Work can be evaluated accurately at any time during performance of the Contract.
- C. Conform Project Construction Schedule to the following requirements:
 - 1. Time of Completion: Adhere to time specified unless an earlier (advanced) time of completion is requested or agreed to by Owner.
 - 2. Construction Schedule Submittal: Within ten working days after receiving notice of award, furnish to Owner a schedule showing general plan for orderly completion of Work, details of planned mobilization of plant and equipment, sequence of early operations and procurement of materials and equipment.
 - 3. Accepted Construction Schedule: Within five working days after receiving notice of acceptance of schedule furnish to Owner one reproducible and three prints of approved schedule.

4. Contractor's Responsibility: Failure of Construction Schedule to include any element of Work, or any inaccuracy in the Construction Schedule will not relieve Contractor from responsibility for accomplishing Work in accordance with the Contract.
5. Float (Slack) Time:
 - a. Amount of time between earliest start date and latest start date or between earliest finish date and latest finish date of activities of Construction Schedule.
 - b. No time extensions or delay costs will be allowed for delays on paths of activities containing float time, providing such delay does not exceed the float time, per the latest updated version of the accepted Construction Schedule.

D. Format of Construction Schedule:

1. Time-scale arrow diagram of the Critical Path Method (CPM) type, or a time-scale precedence diagram. Include in Schedule of Values, itemized descriptions, quantities, and values of work included in each activity in the Construction Schedule.
2. Construction Schedule shall provide the following:
 - a. Time-scaled cost loaded CPM diagram precedence (activity on node) of activities, coordinated with Owner.
 - b. Activity Durations:
 - 1) Total of actual days required to perform that activity including consideration of weather impact on completion of that activity.
 - 2) No duration longer than 14 days, with exception of procurement activities, unless otherwise acceptable to Owner.
 - c. Sufficient detail to show plan for completion of Work for each stage within time specified.
 - d. Milestone activities showing point of completion for each stage of Work.
 - e. Dependencies (or relationships) and logic between activities.
 - f. Information for material or equipment to be provided as follows:
 - 1) Material or equipment description.
 - 2) Duration in days required for preparation and review of Submittals.
 - 3) Duration in days required for fabrication and delivery
 - 4) Restraints (ties) to activities which will be constrained by delivery date of materials or equipment item.

- 5) Scheduled delivery dates.
 - g. Total contract value to be earned from performing each activity shall be the total of labor, material and equipment, including overhead and profit. Any material value assigned shall be actual invoice value of material, without markup. Sum of the value of items in Construction Schedule and Schedule of Values shall equal total contract value.
 - h. Assign a responsibility code/organization code for each activity, as approved by Owner.
 - i. Assign at least seven days for development of punch list(s), completion of punch list items, and final cleanup.
- E. Acceptance of Construction Schedule will not relieve Contractor of responsibility for accomplishing Work in accordance with the Contract
- F. Monthly Updates: Submit an up-to-date Status Report each month to include:
1. Estimated physical percentage complete for each activity in progress.
 2. Actual start/finish dates for all activities as appropriate.
 3. List of materials and/or equipment delivered for which payment is requested and an original paid invoice verifying cost.
 4. Identification of processing errors, if any, on previous update report.
 5. Identification of activities which are affected by proposed Change Orders issued during the update period (Network Window).
 6. Resolution of conflict between actual work progress and schedule logic. If out of sequence activities developed in schedule due to actual construction progress, submit revisions to schedule logic to conform to current job status and direction.
 7. Owner will review updated information and meet with Contractor each month to ascertain status of Work.
 8. Progress payments pursuant to the Agreement will be approved only after receipt of timely, accurately updated Schedule and Schedule of Values and will be based on the update of the Schedule of Values. Contractor and Owner will jointly review progress and agree upon quantity of work completed prior to Contractor's submittal of revised Schedule of Values and invoice.
- G. Contract Schedule Revisions:
1. If there are significant changes in plan of construction from that shown in accepted Construction Schedule, as determined by Owner, Contractor shall, within ten working days after receiving notice, submit a revised schedule to Owner for approval.

2. Submitting Project Construction Schedule and updates, if applicable, shall be considered as a necessary portion of Work; therefore, partial payments will not be made until requirement for acceptable schedules has been satisfied.
3. Acceptance of any schedule submitted shall not be construed to assign responsibility of performance or contingencies to Owner, or relieve Contractor of responsibility to adjust forces, equipment, and/or work schedule as may be necessary to ensure completion of Work within prescribed Contract Time period.

1.04 SCHEDULE OF VALUES SUBMITTAL

- A. Submit Schedule of Values to Owner for review within 10 days after Contract execution.
 1. Finalize at least 10 days before the first application for a Progress Payment.
 2. Provide cost breakdown of the various parts of the Work aggregating the total sum of the Contract.
 3. Make out in required detail and support by evidence of correctness.
 4. Owner will coordinate and approve Schedule of Values format.
 5. Include itemized descriptions, quantities, and value of all work included in each activity in the Construction Schedule.
- B. Use Schedule of Values as a basis for applications for monthly Progress Payments, unless later found to be in error.
- C. When applying for each Progress Payment, submit a statement based upon this Schedule of Values.

1.05 SHOP DRAWING SUBMITTALS

- A. Furnish to Engineer for review, four prints of each shop drawing.
 1. The term "shop drawings" shall include detail design calculations, fabrication and installation drawings, lists, graphs, and operating instructions
 2. Unless otherwise required, submit shop drawings a time sufficiently early to allow review by Engineer and to accommodate rate of construction progress under the Contract.
- B. Within fifteen calendar days after receipt of prints Engineer will return prints of each drawing to Contractor with comments noted.
 1. It is considered reasonable that Contractor shall make a complete and acceptable submittal by the second submission of drawings.
 2. Owner reserves the right to withhold monies due Contractor to cover additional costs of Engineer's review beyond second submission.

- C. If three prints of drawing are returned to Contractor marked NO EXCEPTIONS TAKEN, a formal revision of drawing will not be required.
- D. If three prints of drawing are returned to Contractor marked MAKE CORRECTIONS NOTED, a formal revision of drawing will not be required.
- E. If one print of drawing is returned to Contractor marked AMEND-RESUBMIT or REJECTED-RESUBMIT, Contractor shall revise drawing and resubmit eight copies of revised drawing to Engineer for review.
- F. Fabrication of an item shall not be commenced before Engineer has reviewed pertinent shop drawings and returned copies to Contractor marked NO EXCEPTIONS TAKEN or MAKE CORRECTIONS NOTED.
 - 1. Revisions indicated on shop drawings shall be changes necessary to meet requirements or Drawings and Specifications and shall not be taken as basis of claims for extra work.
 - 2. Contractor shall have no claim for damages or extension of time due to delay resulting from Contractor's having to make required revisions to shop drawings (unless review by Engineer of drawings is delayed beyond a reasonable period of time and unless the Contractor can establish that Engineer's delay in review actually resulted in delay in Contractor's construction schedule).
 - 3. Review of drawings by Engineer will be limited to checking for general agreement with Specifications and Drawings, and shall in no way relieve Contractor of responsibility for errors or omissions contained therein, nor shall such review operate to waive or modify any provision contained in Specifications or Drawings.
- G. Engineer's review of shop drawing Submittals shall not relieve Contractor of entire responsibility for correctness of details and dimensions.
 - 1. Contractor shall assume all responsibility and risk for misfits due to errors in Contractor submittals.
 - 2. Contractor shall be responsible for:
 - a. Dimensions and design of adequate connections and details.
 - b. Fabricating dimensions.
 - c. Quantities of materials.
 - d. Applicable code requirements.
 - e. Other Contract requirements.
- H. Engineer shall have authority to reject any product upon completion of review of suppliers' Submittals in regard to proof of acceptability of the product

1.06 CERTIFICATES OF INSPECTION

- A. When specified in individual specification sections, submit inspection certification by appropriate entity to Owner in quantity specified.
- B. Certificates shall be acceptable to Owner.
- C. Indicate Work conforms to or exceeds specified requirements. Submit supporting reference data, affidavits, and certifications as appropriate.

1.07 SPARE PARTS LISTS SUBMITTAL

- A. Furnish to Owner eight identical sets of spare parts information for instrumentation, mechanical, and electrical equipment.
- B. Include current list price of each spare part.
- C. Limit list to those spare parts which each manufacturer recommends be maintained by Owner in inventory at the site.
- D. Each manufacturer or supplier shall indicate name, address, and telephone number of nearest outlet of spare parts to facilitate Owner in ordering.
- E. Cross-reference spare parts lists to equipment numbers designated in Construction Documents.
- F. Bind spare parts lists in standard size, 3-ring, loose leaf, vinyl plastic hard cover binders suitable for bookshelf storage. Binder ring size shall not exceed 2.5 inches.

1.08 MIX DESIGN SUBMITTALS

- A. Prepare Portland cement concrete and asphalt concrete mix designs.
 - 1. Determine exact proportions of materials to be used for different parts of Work, in conformance with Drawings and Specifications.
 - 2. Submit to Engineer for review prior to use in Work
- B. Samples for mix design shall represent existing stockpile.
 - 1. Mix designs "copied" from previous projects will not be accepted unless the existing stockpile aggregate is tested to assure conformity.
 - 2. Any stockpile additive, binder or cement source location and/or type of material change will require a new mix design.

1.09 OMISSIONS OR ERRORS IN SUBMITTED DATA

- A. Pay costs involved in correcting omissions or errors in submitted data, including failure to make timely submittal.

- B. Pay costs involved in correcting omissions or errors in execution of correctly submitted information.
- C. Costs shall include additional compensation due to Owner and Engineer due to additional services necessitated by the change.

PART 2 PRODUCTS

Not used.

PART 3 EXECUTION

Not used.

END OF SECTION

SECTION 01400

QUALITY CONTROL

PART 1 GENERAL

1.01 SECTION INCLUDES

- A. Quality assurance - control of installation.
- B. Tolerances.
- C. Inspecting and testing laboratory services.
- D. Manufacturers' field services and reports.
- E. Inspection at place of manufacture.

1.02 QUALITY ASSURANCE - CONTROL OF INSTALLATION

- A. Monitor quality control over suppliers, manufacturers, products, services, site conditions, and workmanship, to produce Work of specified quality.
- B. Comply with manufacturer's instructions, including each step in sequence.
- C. Should manufacturers' instructions conflict with Construction Documents, request clarification from Engineer before proceeding.
- D. Comply with specified standards as minimum quality for the Work except where more stringent tolerances, codes or specified requirements indicate higher standards or more precise workmanship.
- E. Perform work by persons qualified to produce workmanship of specified quality.
- F. Secure Products in place with positive anchorage devices designed and sized to withstand stresses, vibration, physical distortion, or disfigurement.

1.03 TOLERANCES

- A. Monitor tolerance control of installed Products to produce acceptable Work. Do not permit tolerances to accumulate.
- B. Comply with manufacturers' tolerances. Should manufacturers' tolerances conflict with Construction Documents, request clarification from Engineer before proceeding.
- C. Adjust Products to appropriate dimensions; position before securing Products in place.

1.04 INSPECTING AND TESTING LABORATORY SERVICES

- A. Owner will appoint, employ, and pay for specified services of an independent firm to perform inspecting and testing.
- B. The independent firm will perform inspections, tests, and other services specified in individual specification sections and as required by Engineer and Owner.
- C. Inspecting, testing and source quality control may occur on or off the project site. Perform offsite inspecting or testing as required by Engineer or Owner.
- D. Reports will be submitted by the independent firm to Engineer, in duplicate, indicating observations and results of tests and indicating compliance or noncompliance with Construction Documents.
- E. Cooperate with independent firm; furnish samples of materials, design mix, equipment tools, storage, safe access, and assistance by incidental labor as required.
 - 1. Notify Engineer and independent firm 24 hours prior to expected time for operations requiring services.
 - 2. Make arrangements with independent firm and pay for additional samples and tests required for Contractors use.
- F. Testing and inspecting does not relieve Contractor to perform Work to Contract requirements.
- G. Retesting required because of non-conformance to specified requirements shall be performed by the same independent firm on instructions by Engineer. Payment for retesting will be charged to Contractor by deducting inspecting or testing charges from the Contract Price.

1.05 MANUFACTURERS' FIELD SERVICES AND REPORTS

- A. When specified in individual specification sections, require material or Product suppliers or manufacturers to provide qualified staff personnel to observe site conditions, conditions or surfaces and installation, quality of workmanship, start-up of equipment, and test, adjust and balance of equipment as applicable, and to initiate instructions when necessary.
- B. Submit qualifications of observer to Engineer 30 days in advance of required observations.
- C. Report observations and site decisions or instructions given to applicators or installers that are supplemental or contrary to manufacturers written instructions.
- D. Submit report in duplicate within 30 days of observation to Engineer for information.

1.06 INSPECTION AT PLACE OF MANUFACTURE

- A. Products, materials, and equipment shall be subject to inspection by Engineer at place of manufacture.

- B. Presence of Engineer at place of manufacture shall not relieve Contractor of responsibility for finishing products, materials, and equipment which comply with requirements of the Construction Documents.
- C. Compliance is a duty of Contractor which shall not be avoided by any act or omission on the part of Engineer.

PART 2 PRODUCTS

Not used.

PART 3 EXECUTION

Not used.

END OF SECTION

SECTION 01505

MOBILIZATION

PART 1 GENERAL

1.01 DESCRIPTION

- A. Mobilization shall include obtaining permits; moving plant and equipment onto site; furnishing and erecting plants, temporary buildings, and other construction facilities, as required for the proper performance and completion of the Work
- B. Mobilization shall include the following principal items:
 - 1. Moving onto the site of plant and equipment required for first month operations including field office for Owner.
 - 2. Installing temporary construction power, wiring, and lighting facilities.
 - 3. Establishing fire protection system.
 - 4. Developing construction water supply.
 - 5. Providing onsite communication facilities.
 - 6. Providing onsite sanitary facilities and potable water facilities as specified.
 - 7. Arranging for and erection of work and storage yard.
 - 8. Obtaining required permits.
 - 9. Posting OSHA required notices and establishment of safety programs.
 - 10. Having the superintendent at the jobsite full time.
 - 11. Submitting Preliminary Construction Schedule.

PART 2 PRODUCTS

Not used.

PART 3 EXECUTION

Not used.

END OF SECTION

SECTION 01515

TEMPORARY UTILITIES AND CONSTRUCTION FACILITIES

PART 1 GENERAL

1.01 SUMMARY

- A. Provide plant and equipment adequate for performance of the work within the time specified.
- B. Keep plant and equipment in satisfactory operating condition, capable of safely and efficiently performing the required Work, and subject to inspection and approval by Owner or Engineer at any time during the Work.
- C. Nothing in this section is intended to limit types and amounts of temporary work required, and no omission from this section will be recognized as an indication by Owner that such temporary activity is not required for successful completion of Work and compliance with requirements of Construction Documents.
- D. Conform to applicable requirements of OSHA Standards for Construction.
- E. Dispose of temporary construction facilities when no longer needed or at completion of the Contract, unless otherwise requested in writing by Owner or specified. Repair damage caused by the installations.

1.02 TEMPORARY ELECTRICITY

- A. Temporary connections for stand-by power shall be subject to approval of Owner.

1.03 TEMPORARY WATER SERVICE

- A. Temporary water service for construction and sanitary needs will be provided by the Contractor throughout the construction period.
 - 1. Contractor will provide facilities necessary to obtain water required for Work.
 - 2. Owner will obtain necessary permits and pay any utility service provider fees in force for construction water.
- B. Potable Water
 - 1. Contractor will furnish drinking water onsite during construction which is bottled water or water furnished in approved metal dispensers.
 - 2. Post notices conspicuously throughout the site warning personnel that piped water may be contaminated.
- C. Water Connections:

1. Do not make connection to, or draw water from, any fire hydrant or pipeline without first obtaining permission of the authority having jurisdiction over the use of fire hydrant or pipeline and from the agency owning the affected water system.
2. For each such connection made, first attach to fire hydrant or pipeline a valve and a meter, if required by the authority, of a size and type acceptable to authority and agency.

D. Removal of Water Connections:

1. Before final acceptance of Work, entirely remove temporary connections and piping.
2. Restore affected improvements to original condition, or better, to satisfaction of Owner and to agency owning affected utility.

E. The City will provide water for construction purposes.

1.04 TEMPORARY SANITARY FACILITIES

A. Comply with sanitary requirements prescribed by local or state health departments.

B. Sanitary and Other Organic Wastes:

1. Establish regular collection of sanitary and organic wastes.
2. Dispose of wastes and refuse from sanitary facilities provided by Contractor, or organic material wastes from sources related to Contractor's operations, away from site in a manner satisfactory to Owner and Engineer and in accordance with all laws and regulations.

C. Toilet Facilities:

1. Provide fixed or portable chemical toilets wherever needed for use of employees.
2. Toilets at construction job sites shall conform to requirements of Part 1926 of OSHA Standards for Construction.

PART 2 PRODUCTS

Not used.

PART 3 EXECUTION

Not used.

END OF SECTION

SECTION 01530

PROTECTION OF EXISTING FACILITIES

PART 1 GENERAL

1.01 SUMMARY

- A. Protect existing utilities and improvements not designated for removal.
- B. Restore damaged or temporary relocated utilities and improvements to a condition equal to or better than they were prior to such damage or temporary relocation.
- C. Verify exact locations and depths of utilities shown and make exploratory excavations of utilities that may interfere with Work.
 - 1. Perform exploratory excavations as soon as practicable after award of Contract and in sufficient time in advance of construction to avoid possible delays to Work.
 - 2. When exploratory excavations show utility location as shown to be in error, notify Engineer.
- D. The number of exploratory excavations required shall be sufficient to determine alignment and grade of existing utilities.

1.02 RIGHTS-OF-WAY

- A. Access to lands or rights-of-way for the Work will be provided by Owner as shown on the Drawings.
 - 1. Nothing contained in the Construction Documents shall be interpreted as giving Contractor exclusive occupancy of the lands or rights-of-way provided.
 - 2. Additional lands or rights-of-way required for construction operations shall be provided by Contractor at his own expense.
- B. Do not enter nor occupy with men, equipment, or materials, any lands outside the rights-of-way or easements shown without meeting the following requirements:
 - 1. Furnish to Owner, prior to use of any other public or private properties by Contractor in performance of Work, written authorization by the property owner for use of such property by Contractor.
 - 2. Prior to acceptance of Work by Owner, furnish Owner with written evidence, acceptable to Owner, releasing Contractor from liability to the property owner for the use of such property by Contractor.
 - 3. Take precautions necessary to preserve private and public property in immediate area of work site.

4. Total liability shall be assumed by Contractor for damage to private and/or public property during the prosecution of Work.
5. Upon completion of Work all private and public property shall be, as a minimum, restored to its conditions existing prior to the commencement of work thereon.

1.03 PROTECTION OF STREET OR ROADWAY MARKERS

- A. Do not destroy, remove, or otherwise disturb existing survey markers or other existing street or roadway markers without proper authorization.
- B. Start no pavement breaking or excavation until survey or other permanent marker points that will be disturbed by the construction operations have been properly referenced for easy and accurate restoration.
- C. Notify Engineer of the time and location that work will be done, sufficiently in advance of construction to avoid delay due to waiting for survey points to be satisfactory referenced for restoration.
- D. Survey markers or points disturbed by Contractor without proper authorization by Owner, will be restored by Owner at Contractor's expense after Work has been completed.

1.04 GENERAL RESTORATION OF PAVEMENT

- A. Replace paved areas, including asphaltic concrete berms cut or damaged during construction, with similar materials and of equal thickness to match the existing adjacent undisturbed areas, except where specific resurfacing requirements have been called for in the Contract Documents or in the requirements of the agency issuing the permit.
- B. Temporary and permanent pavement shall conform to the requirements of the owner of the affected pavement.
- C. Pavements subject to partial removal shall be neatly saw-cut in straight lines.

1.05 CONSTRUCTION INTERFERENCES

- A. Contractor's responsibilities regarding existing utilities and construction interferences shall be in accordance with Standard Specifications for Public Works' Construction, Nye County Area, Nevada, and NDOT with the following additional provisions.
- B. Construction interferences include:
 1. Utility or service connections within the limits of excavation or over-excavation required for the Work
 2. Utility or service connections located in the space which will be required by the Work.
 3. Utility or service connections required to be disturbed or removed to permit construction as specified under the Contract.

- C. Disturb or remove connections only with approval of owner and following notification to owner of interfering utility or service connection.
- D. Promptly reconstruct utility or service connections removed or otherwise disturbed in original or other authorized location in a condition at least as good as prior to such removal or disturbance, subject to the inspection of utilities' owners.
- E. Contractor's responsibility to remove or replace shall apply even in if damage or destruction occurs after backfilling.
- F. Immediately notify owner of utility if service connection damage or destruction occurs or is discovered.
- G. During the performance of the Work, the owner of any utility affected by the Work shall have the right to enter when necessary upon any portion of the Work for the purpose of maintaining service and of making changes in or repairs to the utility.
- H. Contractor shall not be held responsible for failure to complete the Work on time to the extent that such delay was caused by failure of the owner or of the agency having jurisdiction over the utility or service connection to authorize or otherwise provide for its removal, relocation, protection, support, repair, maintenance, or replacement.
- I. Exercise extreme care not to damage existing utilities and/or new and existing facilities which do not physically constitute a construction interference.
 - 1. Use equipment of such weights throughout construction operations so that existing buried utilities and/or new and existing facilities are not damaged by excessive loadings.
 - 2. Contractor shall be responsible for costs of repair and/or replacement of new or existing facilities damaged by construction operations, as determined by Owner.
- J. Contact "CALL BEFORE YOU DIG" not less than 48 hours prior to starting any excavation. Notify by telephone and comply with all instructions received; the toll free number is 1-800-227-2600 or 811.
 - 1. All utility companies may not be members of the USA System and, therefore, not automatically contacted by the above referenced telephone number.
 - 2. Contractor shall be responsible for making himself aware of utility company facilities not reported by the USA System, and shall bear any and all damages stemming from repair or delay costs or any other expenses resulting from the unanticipated discovery of underground utilities.
 - 3. Notify the pertinent utilities at least two working days in advance of commencement of work at site, to examine the construction site and mark the location of the utilities' respective facilities. Verify that each utility has responsibly responded to the notification.

PART 2 PRODUCTS

Not used.

PART 3 EXECUTION

Not used.

END OF SECTION

SECTION 01535

SAFETY

PART 1 GENERAL

1.01 SUMMARY

- A. Nothing contained in this section is intended to limit the types and amounts of safety precautions required.
- B. No omission from this section will be recognized as an indication by the Owner that such safety precautions are not required for successful completion of the Work and compliance with requirements of Contract Documents.

1.02 SAFETY PROTECTION

- A. Prior to starting and during progress of the Work, prevent hazards to personnel and property, including that of the Owner, Engineer, subcontractors, separate contractors, the neighborhood, and the public.
- B. Provide for proper care, safety, and protection of materials, installed work, personnel, and equipment.
- C. Precautions taken for safety and protection shall not relieve Contractor from liability due to accidents or any other cause.

1.03 COMPLIANCE WITH SAFETY PROGRAM

- A. Implement and enforce a safety program consistent with the needs and objectives of the Owner.
- B. Comply with the requirements of federal, state, and local regulations governing safety.
- C. Provide personal protective equipment as defined by state and federal laws. Such equipment shall be worn by employees (hard hats, eye protection, etc.)
- D. Hold weekly safety meetings with subcontractors and report items discussed to the Owner and Engineer on a weekly basis.
- E. Lower tier subcontractors shall conduct weekly toolbox meetings and weekly safety - inspections of its areas and equipment. Equipment so required by law (such as cranes and cables) shall be inspected dally.
- F. Thoroughly investigate accidents to the degree satisfactory to the Owner.
- G. Submit weekly written reports to the Owner for the following items:
 - 1. Safety meetings.

2. Area and equipment inspection
3. Accident investigations and statistics.

PART 2 PRODUCTS

Not used.

PART 3 EXECUTION

Not used.

END OF SECTION

SECTION 01550

ACCESS ROADS AND PARKING AREAS

PART 1 GENERAL

1.01 SUMMARY

- A. Furnish and maintain vehicular access to the site and within the site to provide uninterrupted access:
 - 1. To temporary construction facilities.
 - 2. To storage and work areas which are for use by persons and equipment involved in the construction of this and adjacent projects.
 - 3. For access by emergency vehicles.

1.02 TEMPORARY CROSSINGS

- A. Wherever necessary or required for convenience of the public or individual residents at street or highway crossings, private driveways, or elsewhere, provide suitable temporary bridges or steel plates over unfilled excavations.
 - 1. Exceptions require written consent of individuals or authorities concerns to omit such temporary bridges or steel plates and delivery of the written consent to Owner prior to excavation.
 - 2. Maintain bridges or steel plates in service until access is provided across backfilled excavation.
 - 3. Conform temporary bridges or steel plates for street and highway crossings to requirements of the authority having jurisdiction in each case; adopt designs furnished by the authority for the bridges or steel plates or submit designs to the authority for approval, as may be required.
- B. Street Use:
 - 1. Nothing herein shall be construed to entitle Contractor to exclusive use of any public street, alleyway, or parking area during the performance of the Work.
 - 2. Conduct operations to not interfere unnecessarily with authorized work of utility companies or other agencies in the streets, alleyways, or parking areas.
 - 3. Close no street to the public without first obtaining permission of Owner and proper governmental authority.

4. Where excavation is being performed in primary streets or highways, one lane in each direction shall be kept open to traffic at all times unless otherwise provided or shown.
 5. Provide toe boards to retain excavated material if required by Owner or agency having jurisdiction over the street or highway.
 6. Keep fire hydrants on or adjacent to the Work accessible to fire-fighting equipment at all times.
 7. Make temporary provisions to assure the use of sidewalks and proper functioning of gutters, sewer inlets, and other drainage facilities.
- C. Street Closure: If closure of any street is required during construction, make formal application for street closure to authority having jurisdiction at least 30 days prior to the required street closure in order to determine necessary sign and detour requirements.

1.03 ACCESS ROADS

- A. Provide access roads that may be required as approved by Owner.
- B. Keep roads clean of construction spillage and debris at all times.
- C. Repair damages caused to roads or adjacent property by Contract related construction vehicles by replacing damaged pavement, landscaping, concrete and other adjacent property to match new or existing construction.
- D. Locate access roads, drives, walks and parking facilities to provide uninterrupted access to construction offices, mobilization, work and storage areas, and other areas required for execution of the Contract.
- E. Use, maintain, and repair local public roads in strict conformance with local and state codes, regulations and ordinances at no expense to Owner.

1.04 CONSTRUCTION PARKING

- A. Provide parking facilities adequate for the needs of project personnel, as approved by Owner.
- B. Maintain parking area for construction vehicles.

1.05 CONTRACTOR'S WORK AND STORAGE AREA

- A. Make arrangements for offsite storage, staging, or shop areas which may be necessary for proper execution of the Work.

PART 2 PRODUCTS

Not used.

PART 3 EXECUTION

Not used.

END OF SECTION

SECTION 01560

TEMPORARY ENVIRONMENTAL CONTROLS

PART 1 GENERAL

1.01 SUMMARY

- A. Provide and maintain control over environmental conditions at the construction site and related areas under Contractor's control.
- B. Remove physical evidence of temporary facilities upon completion of the Work.
- C. Section includes:
 - 1. Dust Control.
 - 2. Water Control.
 - 3. Debris Control.
 - 4. Pollution Control.
 - 5. Explosives and Blasting.
 - 6. Barriers.
 - 7. Protection of Installed Work.
 - 8. Security.
 - 9. Chemicals.

PART 2 PRODUCTS

Not used.

PART 3 EXECUTION

3.01 DUST CONTROL

- A. Provide positive methods and application of dust control materials as necessary to minimize dust from construction operations.
- B. Provide positive means to prevent airborne dust from disbursing into the atmosphere. See Article 3.05, this section.

3.02 WATER CONTROL

- A. Control surface water and prevent damage to the Project, the site, and adjoining properties.
- B. Furnish, place, and maintain supports and shoring required for the sides of the excavations.
- C. Properly dispose of onsite storm drainage water and divert offsite drainage to prevent flooding, erosion, or other damage to any portion of the site or to adjoining areas.

3.03 DEBRIS CONTROL

- A. Keep all areas under Contractor's control free from extraneous debris; at all times keep work area in a neat, clean, and safe condition.
- B. Initiate and maintain a specific program to prevent accumulation of debris at the site, in storage and parking areas, and along access roads and haul routes, as follows:
 - 1. Provide containers for deposit of debris.
 - 2. Prohibit overloading of trucks to prevent spillage on access and haul routes.
 - 3. Perform periodic inspections to enforce these requirements.
- C. Schedule periodic collection and disposal of debris and provide additional collection and disposal of debris whenever the periodic schedule is inadequate to prevent accumulation.
- D. If Contractor fails to clean up as provided in Construction Documents, Owner may do so and cost thereof will be charged to Contractor.

3.04 POLLUTION CONTROL

- A. Prevent contamination of soil, water or atmosphere by the discharge of noxious substances from construction operations, including equipment personnel and emergency measures required to contain any spillage, and to remove contaminated soils or liquids.
 - 1. After obtaining proper approvals, excavate and dispose of contaminated earth offsite, and replace with suitable compacted fill and topsoil.
- B. Take special precautions to prevent harmful substances from entering public waters.
 - 1. Prevent disposal of wastes, effluents, chemicals or other substances adjacent to washes, or in sanitary or storm sewers.
- C. Control atmospheric pollutants to prevent toxic concentrations of chemicals, and to prevent harmful dispersal of pollutants into the atmosphere.
- D. This project is located in Nye County, Nevada.
 - 1. Contact the State Health Bureau (Air Pollution Control Division) regarding special considerations concerning air quality requirements in Nye County.

2. Compliance with all rules, regulations, special stipulations and laws pertaining to air quality shall be Contractor's responsibility and the cost thereof shall be considered in the Contract lump sum price.

E. Applications for Operating Permits and for Authority to Construct facilities for extracting and processing of onsite materials shall be the Contractor's responsibility.

3.05 EXPLOSIVES AND BLASTING

A. The use of explosives on the Work will not be permitted.

3.06 BARRIERS

A. Provide barriers to prevent unauthorized entry to construction areas and to protect existing facilities and adjacent properties from damage from construction operations.

B. Provide protection for plant life designated to remain. Replace damaged plant life.

C. Protect non-owned vehicular traffic, stored materials, site and structures from damage.

3.07 PROTECTION OF INSTALLED WORK

A. Protect installed Work and provide special protection where specified in individual specification sections.

B. Provide temporary and removable protection for installed Work Control activity in immediate work area to prevent damage.

C. Prohibit traffic from landscaped areas.

3.08 SECURITY

A. Protect work, existing premises, and Owner operations from theft, vandalism, and unauthorized entry.

B. Initiate security program in coordination with Owner's existing security system upon receipt of notice to proceed.

3.09 CHEMICALS

A. All chemicals used during project construction or furnished for project operation (i.e., defoliant, soil sterilant, herbicide, pesticide, disinfectant, polymer, reactant or of other classification) shall show approval of either the U.S. Environmental Protection Agency or the U.S. Department of Agriculture.

1. Use of chemicals and disposal of residues shall be in strict accordance with the printed instructions of the manufacturer.

END OF SECTION

SECTION 01600

MATERIALS AND EQUIPMENT

PART 1 GENERAL

1.01 DEFINITIONS

- A. The word "Products" is defined to include purchased items for incorporation into the Work, regardless of whether specifically purchased for the project or taken from Contractor's stock of previously purchased products.
- B. The word "Materials" is defined as products which must be substantially cut, shaped, worked, mixed, finished, refined, or otherwise fabricated, processed, installed, or applied to form units of work.
- C. The word "Equipment" is defined as products with operational parts, regardless of whether motorized or manually operated, and particularly including products with service connections (wiring, piping, and other like items).
- D. Definitions in this Article are not intended to negate the meaning of other terms used in Construction Documents, including "specialties," "Systems," "Structure," "accessories," "special construction," and similar terms, which are self-explanatory and have recognized meanings in the construction industry.

1.02 QUALITY ASSURANCE

- A. Source limitations: To the greatest extent possible for each unit of work, provide products, materials or equipment of a singular generic kind from a single source.
- B. Compatibility of Options:
 - 1. Where more than one choice is available as options for Contractor's selection of a product, material, or equipment, select an option which is compatible with other products, materials, or equipment already selected.
 - 2. Compatibility is a basic general requirement of product/material selections.
- C. Do not use materials and equipment removed from existing premises, except as specifically permitted by the Construction Documents.
- D. Provide interchangeable components of the same manufacturer, for similar components.

1.03 PRODUCT DELIVERY-STORAGE-HANDLING

- A. Deliver, handle, and store products in accordance with supplier's written recommendations and by methods and means which will prevent damage, deterioration, and loss, including theft.

1. Control delivery schedules to minimize long- term storage of products at site and overcrowding of construction spaces.
2. Provide delivery/installation coordination to ensure minimum holding or storage times for products recognized to be flammable, hazardous, easily damaged, or sensitive to deterioration, theft, and other sources of loss.

1.04 TRANSPORTATION AND HANDLING

- A. Transport products to avoid product damage and delivery in undamaged condition in supplier's unopened containers or packing, dry.
- B. Provide equipment and personnel to handle products, materials, and equipment, including those provided by Owner, to prevent soiling and damage.

1.05 STORAGE AND PROTECTION

- A. Store products in accordance with suppliers written instructions, with seals and labels intact and legible.
 1. Store sensitive products in weather- tight enclosures.
 2. Maintain temperature and humidity ranges within tolerances required by supplier's written instructions.
- B. For exterior storage or fabricated products, place on sloped supports above ground.
 1. Cover products subject to deterioration with impervious sheet covering.
 2. Provide ventilation to avoid condensation.
- C. Store loose granular materials on solid surfaces in a well-drained area and prevent from mixing with foreign matter.
- D. Arrange storage to provide access for inspection. Periodically inspect products to assure that products are undamaged and maintained under required conditions.
- E. Arrange storage to provide access for maintenance of stored items.

1.06 MAINTENANCE OF STORAGE

- A. Periodically inspect stored products on scheduled basis. Maintain a log of inspections and make log available to Owner on request.
- B. Verify that storage facilities comply with supplier's product storage requirements.
- C. Verify that supplier required environmental conditions are maintained continually.
- D. Verify that surfaces of products exposed to elements are not adversely affected and that weathering of finishes is acceptable under requirements of Construction Documents.

PART 2 PRODUCTS

Not used.

PART 3 EXECUTION

Not used.

END OF SECTION

SECTION 01630

PRODUCT OPTIONS AND SUBSTITUTIONS

PART 1 GENERAL

1.01 REQUIREMENTS INCLUDED

- A. Contractor's selection of products.
- B. Requests for substitution of products.

1.02 SELECTION OF PRODUCTS

- A. Base bid on products, materials, or systems specified to establish the standard of quality required and to provide a uniform basis for evaluating bids.
- B. Products Specified by Naming Only One Manufacturer:
 - 1. Include that manufacturer in base bid.
- C. Products Specified by Naming One or More Manufacturers:
 - 1. Include first one named in base bid unless a particular section states that any manufacturers listed in that Section may be used in base bid.
- D. When product or manufacturer's names are not specified, provide products, materials, or systems in accordance with performance requirements and install in accordance with material manufacturer's recommendations.
- E. "Or Equal":
 - 1. Where phrases "or equal" or "or approved equal" occur in Construction Documents, do not assume that the products, materials, or system will be approved as equal (even if approved for use on previous projects) until the item has been specifically approved for this work by Engineer.
 - 2. Decision of Engineer shall be final.

1.03 LIMITATIONS ON SUBSTITUTIONS

- A. Substitutions will be considered only when listed on the form provided at the end of this Section (Substitution Request Form).
- B. Only proposed substitutions of Successful Bidder will be reviewed, providing the following procedures have been adhered to:
 - 1. List on Substitution Request Form as specified in Paragraph A.

2. Completely execute Substitution Request Form for each product with substantiating data attached, and signed by authorized representative of Contractor. Submit in quadruplicate.
 3. Deliver requests to Engineer's office within seven calendar days from date of Notice of Award. Late submittals will not be reviewed.
- C. Subsequent requests will be considered in case of product unavailability.
1. Submit a letter to this effect written by the manufacturer accompanied by the completed Substitution Request Form. If, in the opinion of the Engineer, any product specified:
 - a. Cannot be delivered during progress of Work.
 - b. Will no longer be available during progress of Work, or
 - c. If quality of material, as specified, no longer meets Specifications, Engineer will specify a substitute. The material cost differential (credit or extra) between the specified material and the "substitute" will be reflected in a Change Order to Contractor.
 - d. Request for subsequent substitutions may be submitted no later than 30 days after Notice to Proceed is issued.
- D. Substitutions will not be considered when indicated on shop drawings or product data submittals, when requested directly by subcontractor or supplier, or when acceptance will require substantial revisions of Construction Documents.
- E. Substitute products shall not be ordered or installed without written acceptance.
- F. Only one request for substitution for each specified product will be considered. When substitution is not accepted, provide specified product.
- G. Approval, or rejection, of a request for a Substitution will be based on Engineer's opinion, with concurrence by Owner, as to adaptability, durability, quality, aesthetics, and Contract Amount change, when compared to the specified or noted items.

1.04 REQUESTS FOR SUBSTITUTIONS

- A. Identify product by specification section and article numbers. Provide manufacturer's name and address, trade name of product, and model or catalog number. List fabricators and suppliers as appropriate.
- B. Attach product data as specified in Section 01300.
- C. List similar projects using product, dates of installation, and names of Engineers and Owners.
- D. Give itemized comparison of proposed substitution with specified product, listing variations.
- E. Give quality and performance comparison between proposed substitution and the specified product.

- F. Give cost data comparing proposed substitution with specified product, and amount of net change to Contract Amount.
- G. List availability of maintenance services and replacement materials.
- H. State effect of substitution on construction schedule, and changes required in other work or products.

1.05 CONTRACTOR REPRESENTATION

- A. Request for substitution constitutes a representation that Contractor has investigated proposed product and has determined that it is equal to or superior in all respects to specified product. In addition, Contractor:
 - 1. Will provide same warranty for substitution as for specified product.
 - 2. Will coordinate installation of accepted substitute, making such changes as may be required for Work to be complete in all respects.
 - 3. Certifies that cost data presented is complete and includes all related costs under this Contract.
 - 4. Waives claims for additional costs related to substitution which may later become apparent.

1.06 SUBMITTAL PROCEDURES

- A. Submit four copies of request for substitution.
- B. After award of Contract, Engineer will notify Contractor, in writing, of status of requested substitutions with 10 days.
- C. For accepted products, submit shop drawings, product data and samples under provisions of Section 01300.

PART 2 PRODUCTS

Not used.

PART 3 EXECUTION

Not used.

END OF SECTION

SUBSTITUTION REQUEST FORM

DATE: _____ PROJECT TITLE: _____

PROJECT NUMBER: _____ LOCATION: _____

NAME AND ADDRESS OF CONTRACTOR:

SUBMITTED FOR REVIEW TO:

GENTLEMEN:

PLEASE CONSIDER FOR APPROVAL THE FOLLOWING PRODUCT OR SYSTEM AS AN "APPROVED EQUAL" SUBSTITUTION IN ACCORDANCE WITH THE PROVISIONS OF THE CONTRACT DOCUMENTS.

* * * * *

NAME AND DESCRIPTION OF SPECIFIED PRODUCT OR SYSTEM:

SPECIFICATION DIVISION _____ SECTION _____ PAGE(S) _____

DRAWINGS NO(S). _____ DETAIL OR SECTION NO(S) _____

NAME AND DESCRIPTION OF SUBMITTAL FOR SUBSTITUTION:

NAME, ADDRESS, AND TELEPHONE NUMBER OF MANUFACTURER:

NAME, ADDRESS AND TELEPHONE NUMBER OF VENDOR:

* * * * *

REASON(S) FOR NOT GIVING PRIORITY TO SPECIFIED ITEM:

1. SUBSTITUTION AFFECTS OTHER MATERIALS OR SYSTEMS:

___ YES ___ NO

2. SUBSTITUTION REQUIRES DIMENSIONAL REVISION OR REDESIGN OF STRUCTURE: ___ YES ___ NO

(If YES, for 1 and/or 2 above, attach complete data)

3. SAVING OR CREDIT TO OWNER FOR ACCEPTING SUBSTITUTE (even dollar)

\$ _____ (In words: _____ dollars)

4. ATTACH DATA FURNISHED FOR EVALUATION OF SUBSTITUTION:

___ CATALOG, ___ DRAWINGS, ___ SAMPLES, ___ TESTS, ___ REPORTS

___ OTHER.

5. MANUFACTURER'S GUARANTEES OF THE SUBSTITUTE VS SPECIFIED ITEM IS:

___ SAME ___ DIFFERENT (Explain on Attachment)

THE UNDERSIGNED HEREBY CERTIFIES THAT THIS SUBSTITUTION HAS BEEN FULLY CHECKED AND COORDINATED WITH THE CONTRACT DOCUMENTS.

CONTRACTOR: _____ BY: _____

ADDRESS: _____ TITLE: _____

_____ PHONE: () _____

_____ ACCEPTED _____ ACCEPTED AS NOTED _____ NOT ACCEPTED

_____ RECEIVED TOO LATE DATE RECEIVED: _____

DATE OF ACTION: _____ BY: _____

FOR ENGINEER OF RECORD

SECTION 01710

CLEANING

PART 1 GENERAL

1.01 SECTION INCLUDES

- A. Cleaning during progress of the Work and at completion of the Work, as required by conditions of the Contract.

1.02 DISPOSAL REQUIREMENTS

- A. Conduct cleaning and disposal operations to comply with codes, ordinances, regulations, and anti-pollution laws.

1.03 CLEANING DURING CONSTRUCTION

- A. Contractor shall be responsible for Contractor's own waste, debris and cleanup on a regular basis and for maintaining a clean environment
- B. After due notice, Owner will clean up areas of Contractor's work not cleaned up and will charge Contractor the cost thereof, which charge will be deducted from payments due or to become due Contractor.
- C. Remove waste materials, debris and rubbish from the site periodically and dispose of it at legal disposal areas away from the site.
- D. Notwithstanding the conditions stated above, the Contractor shall be solely responsible for the collection and removal of all hazardous material.
- E. Contractor shall execute periodic cleaning to keep the Work, the site and adjacent properties free from accumulations of waste materials, rubbish and wind blown debris, resulting from Construction operations under Contractor's control.
- F. Should the Work involve flammable or combustible liquids, Contractor shall be responsible for removing and disposing of same from project site.

1.04 FINAL CLEANING

- A. Immediately prior to the inspection for substantial completion of the Work, the Contractor shall:
 - 1. Remove Contractor's waste materials and rubbish from the site.
 - 2. Remove all bafflers and other protective devices.
 - 3. Thoroughly clean site to leave it in a rake clean condition, ready for use by Owner.

- B. Immediately prior to the final inspection for completion of the project, Contractor shall:
1. Execute final cleaning prior to final inspection.
 2. Prior to final completion, conduct an inspection of all work areas to verify that the entire work is clean.
 3. Maintain work in a clean condition until the Owner determines the Work and the Project are complete.
 4. Promptly remove from the vicinity of the completed work, all rubbish, unused materials, concrete forms, construction equipment, and temporary structures and facilities used during construction.
- C. Final acceptance of the Work by Owner will be withheld until Contractor has satisfactorily complied with the foregoing requirements for final cleanup of the Project site.

PART 2 PRODUCTS

Not Used.

PART 3 EXECUTION

Not Used.

END OF SECTION

SECTION 01730

OPERATION AND MAINTENANCE DATA

PART 1 GENERAL

1.01 DESCRIPTION

- A. Compile product data and related information appropriate for Owner's maintenance and operation of products furnished under the Contract
- B. Prepare operation and maintenance data as specified in this section and as referenced in other pertinent sections.
- C. Instruct Owner's personnel in the maintenance of products and in the operation of equipment and systems.
- D. Deliver all transmittals to The Owner.
- E. Use two copies of the Exhibit A at the end of this section to transmit each Operation and Maintenance Manual submittal.

1.02 SUBMITTALS

- A. Prepare data in the form of an instructional manual for use by Owner's personnel.
- B. Electronic and Paper Format required. Electronic format in PDF to match Paper Format.
- C. Paper Format:
 - 1. Size: 8-1/2-inch by 11-inch.
 - 2. Paper 20 lb. minimum, white, for typed pages.
 - 3. Text: Manufacturer's printed data, or neatly typewritten.
 - 4. Drawings.
 - a. Provide reinforced punched binder tab, bind in with text.
 - b. Reduced to 6-1/2-inch by 11-inch or 11-inch by 17-inch and folded to 6-1/2-inch by 11-inch.
 - c. Where reduction is impractical, folded and placed in 6-1/2-inch by 11-inch envelopes bound in text.
 - d. Suitably identified on drawings and envelopes.
 - 5. Provide fly-leaf for each separate product, or each piece of operating equipment.
 - a. Provide typed description of product, and major component parts of equipment.
 - b. Provide indexed tabs.
 - 6. Cover: Identify each volume with typed or printed title "OPERATION AND MAINTENANCE INSTRUCTIONS." List:

- a. Title of Project.
- b. Identity of separate structure as applicable.
- c. Identity of general subject matter covered in manual.

7. As much as possible, assemble and bind material in the same order as specified.

D. Binders:

1. Preliminary manuals: Heavy paper covers.
2. Final manuals: Commercial quality substantial, permanent, 3-ring or 3-post binder with durable, cleanable plastic covers.

1.03 QUALITY ASSURANCE

A. Preparation of data shall be done by personnel:

1. Trained and experienced in maintenance and operation of the described products.
2. Completely familiar with requirements of this section.
3. Skilled as a technical writer to the extent required to communicate essential data.
4. Skilled as a draftsman competent to prepare required drawings.

B. Manuals for equipment and systems shall be prepared by the equipment manufacturer or system supplier.

1.04 CONTENT OF MANUALS

A. Neatly typewritten table of contents for each volume, arranged in a systematic order:

1. Contractor, name of responsible principal, address and telephone number.
2. A list of each product required to be included, indexed to the content of the volume.
3. List, with each product, the name, address and telephone number of:
 - a. Subcontractor or installer.
 - b. Maintenance contractor, as appropriate.
 - c. Identify the area of responsibility of each.
 - d. Local source of supply for parts and replacement.

4. Identify each product by product name and other identifying symbols as set forth in Contract Documents.

B. Product Data:

1. Include only those sheets, which are pertinent to the specific product.
2. Annotate each sheet to:

- a. Clearly identify the specific product or part installed.
- b. Clearly identify the data applicable to the installation.
- c. Delete references to inapplicable information.

C. Drawings:

1. Supplement product data with drawings as necessary to clearly illustrate:
 - a. Relations of component parts of equipment and systems.
2. Coordinate drawings with information in Project Record Documents to assure correct illustration of completed installation.
3. Do not use Project Record Documents as maintenance drawings.

D. Written text, as required to supplement product data for the particular installation.

1. Organize in a consistent format under separate headings for different procedures.
2. Provide a logical sequence of instructions for each procedure.

E. Copy of each Warranty, Bond and Service Contract Issued.

1. Provide information sheet for Owner's personnel, give:
 - a. Proper procedures in the event of failure.
 - b. Instances, which might affect the validity of warranties or bonds.

F. Completed Maintenance Record Data on Form Exhibit B.

1.05 MANUALS FOR EQUIPMENT AND SYSTEMS

A. Provide an operation and maintenance manual for each item of equipment or system listed in the schedule of manuals in the quantity listed in the submittal schedule.

B. Content, for each unit of equipment and system, as appropriate.

1. Description of unit and component parts.
 - a. Function, normal operating characteristics, and limiting conditions.
 - b. Engineering data and tests.
 - c. Complete nomenclature and commercial number of all replaceable parts.
2. Operating procedures.
 - a. Start-up, break-in, routine and normal operating instructions.
 - b. Regulation, control, stopping, shutdown and emergency instructions.
 - c. Summer and winter operating instructions, as applicable.
 - d. Special operating instructions.
3. Maintenance procedures.

- a. Routing operations.
 - b. Guide to "trouble-shooting."
 - c. Disassembly, repair and reassembly.
 - d. Alignment adjusting and checking.
4. Servicing and lubricating schedule.
 - a. Use of lubricants required.
 5. Manufacturer's printed operating and maintenance instructions.
 6. Description of sequence of operation by control manufacturer.
 7. Original manufacturer's parts list, illustrations, assembly drawings and diagrams required for maintenance.
 - a. Predicted life of parts subject to wear.
 - b. Items recommended to be stocked as spare parts.
 8. Each contractor's coordination drawings.
 - a. As-installed color-coded piping diagrams.
 9. Charts of valve tag numbers, with the location and function of each valve.
 10. List of original manufacturer's spare parts, manufacturer's current prices, and recommended quantities to be maintained in storage.
 11. Other data as required under pertinent sections of specifications.
- C. Prepare and include additional data when the need for such data becomes apparent during instruction of Owner's personnel.
 - D. Additional Requirements for Operating and Maintenance are given in the detailed equipment specifications.

1.06 SUBMITTAL SCHEDULE

A. Manuals for Equipment and Systems:

1. Submit three preliminary copies prior to the date of shipment of the equipment or system.
 - a. The Owner will review.
 - b. If acceptable, one copy will be returned to Contractor, one copy sent to Resident Project Representative and one copy retained in Owner's File.
 - c. If unacceptable, two copies will be returned to Contractor with Owner's comments for revision and one copy retained in Owner's file. Resubmit three revised preliminary copies for Owner's review.
 - d. No partial payments will be made for equipment and systems on hand or installed until preliminary manuals are submitted.
2. Submit six final copies no less than 30 days prior to putting the equipment or system in service. If final manuals differ from accepted preliminary manuals, submit two copies of

any necessary supplemental material, with instructions for insertion, for conforming Owner's and resident Project Representative's copies of preliminary manuals to final manuals.

- a. The Owner will compare with accepted preliminary manual.
- b. If identical, or otherwise acceptable, Contractor will be so notified. One copy will be transmitted to Owner, five copies will be held for later transmittal to the Owner.
- c. If not acceptable, all six copies will be returned to Contractor for revision or retained by the Owner and the necessary revision data requested from Contractor, at the Owner's option.
- d. No portion of the Work is substantially complete until final equipment and system manuals relating to that portion of the Work are accepted by The Owner.
- e. Submit eight copies of any revisions found desirable during instruction of Owner's personnel, with instructions for insertion, for revising the Owner's and Resident Project Representatives copies of manual.

1.07 INSTRUCTION OF OWNER'S PERSONNEL

- A. Prior to final inspection or acceptance, fully instruct the Owner's designated operating and maintenance personnel in the start-up, operation, adjustment and maintenance of all products, equipment and Systems.
- B. Operation and Maintenance Manual shall constitute the basis of instruction:
 1. Review contents of manual with personnel in full detail to explain all aspects of operations and maintenance.
- C. Additional requirements for specialized instruction of Owner's personnel are given in the detailed equipment specifications.

1.08 SCHEDULES

- A. Equipment and Systems Operation and Maintenance Manuals shall be prepared for each of the following.

<u>Specification Section</u>	<u>Type of Equipment or System</u>
02670	Valves (including motor-operators)
15120	Pressure Transmitter
15121	Pressure Reducing/Sustaining Valve
15122	Magnetic Flowmeter
15430	Backflow Preventers
15431	Agricultural Sprinkler Irrigation Systems

END OF SECTION

SECTION 01740

WARRANTIES

PART 1 GENERAL

1.01 SECTION INCLUDES

- A. Contractor's One Year warranty.
- B. Product and Service Warranties.
- C. Preparation and submittal.
- D. Time and schedule of submittals.

1.02 CONTRACTOR'S ONE YEAR WARRANTY

- A. Unless otherwise provided, materials and equipment incorporated into Work shall be new and, where not specified, of the most suitable grade of the respective kinds, for the intended use, and workmanship shall be in accordance with construction practices acceptable to Owner.
- B. Unless otherwise provided, warrant equipment, materials, and labor furnished or performed under this Contract against defects in design, materials and workmanship (unless furnished by Owner), for a period of twelve months (unless longer guarantees or warranties are provided for elsewhere in Construction Documents in which case the longer guarantees or warranties shall prevail) after final acceptance, regardless of whether furnished or performed by Contractor or subcontractors of any tier.
 - 1. Upon receipt of written notice form Owner of any defect in equipment, materials, or labor during the applicable warranty period, due to defective design, materials or workmanship, the affected items or parts thereof shall be redesigned, repaired or replaced by Contractor at a time acceptable to Owner.
- C. Perform tests Owner may require to verify that redesign, repairs and replacements comply with requirements of Contract.
 - 1. Costs incidental to such redesign, repair, replacement and testing, including the removal, necessary to gain access, shall be borne by Contractor.
- D. Warrant redesigned, repaired or replaced work against defective design, materials and workmanship for a period of twelve months from and after date of acceptance thereof.
 - 1. Should Contractor fail to promptly make the necessary redesign. repair, replacement and test, Owner may perform or cause to be performed the same at Contractor's expense.
 - 2. Contractor and its surety or sureties shall be liable for the satisfaction and run performance of the warranties as set forth herein.

1.03 PRODUCT AND SERVICE WARRANTIES

A. Warrant to Owner:

1. That materials and equipment furnished will be of good quality and new unless otherwise required or permitted by Construction Document.
2. That Work will be free from defect not inherent in the quality required or permitted.
3. That Work will conform with all requirements of the Construction Documents.

B. Work not conforming to requirement, including substitutions not properly approved and authorized, may be considered defective.

C. Contractor's warranty excludes remedy for damage or defect caused by abuse, modifications not executed by the Contractor, improper or insufficient maintenance, improper operation, or normal wear and tear under normal usage.

D. If required by Owner, furnish satisfactory evidence as to the kind and quality of materials and equipment.

PART 2 PRODUCTS

Not Used

PART 3 EXECUTION

3.01 FORM OF SUBMITTALS

A. Bind in commercial quality 6-1/2 x 11-inch three D side ring binders with durable plastic covers.

B. Cover: identify each binder with typed or printed title WARRANTIES, with title of Project; name, address and telephone number of Contractor and equipment supplier; and name of responsible company principal.

C. Table of Contents: Neatly typed, in sequence of Table of Contents of Project Manual, identifying each item with number and title of specification section in which specified, and name of Product or work item.

D. Separate each warranty of bond with index tab sheets keyed to the Table of Contents listing.

1. Provide full information, using separate typed sheets as necessary.

2. List Subcontractor, supplier, and manufacturer, with name, address, and telephone number of responsible principal.

3.02 PREPARATION OF SUBMITTALS

- A. Obtain warranties and bonds, executed in duplicate by responsible Subcontractors, manufacturers, and suppliers within 10 days after completion of the applicable item of work.
 - 1. Except for items put into use with Owner's permission, leave date of beginning of time of warranty until the Date of Substantial completion is determined.
- B. Verify that documents are in proper form, contain run information, and are notarized.
- C. Co-execute submittals when required.
- D. Retain warranties and bonds until time specified for submittal.

3.03 TIME OF SUBMITTALS

- A. For equipment or component parts of equipment put into service during construction with Owner's permission, submit documents within ten days after acceptance.
- B. Make other submittals within 10 days after Date of Substantial Completion, prior to final Application for Payment.
- C. For items of Work for which acceptance is delayed beyond Date of Substantial Completion, submit within ten days after acceptance, listing the date of acceptance as the beginning of the warranty period.

3.04 WARRANTIES

- A. Provide duplicate notarized copies.
- B. Execute and assemble transferable warranty documents from Subcontractors, suppliers, and manufacturers.
- C. Submit prior to final Application for Payment.
- D. For items of Work delayed beyond date of Substantial Completion, provide updated submittal within 10 days after acceptance, listing date of acceptance as start of warranty period.

END OF SECTION

SECTION 02200

EARTHWORK

PART 1 GENERAL

1.01 SUMMARY

- A. Furnish all labor, equipment, materials and services for the performance of all earthwork required for completion of all Work specified.
- B. Such earthwork shall include, but not be limited to, the loosening, removing, loading, transporting, depositing, and compacting in its final location of all materials wet and dry, as required for the purposes of completing the Work, which shall include, but not be limited to:
 - 1. The finishing, placing, and removing of sheeting and bracing necessary to safely support the sides of all excavation.
 - 2. All pumping, ditching, draining, and other required measures for the removal or exclusion of water from the excavation.
 - 3. The supporting of structures above and below the ground.
 - 4. All backfilling around structures and all backfilling of trenches and pits.
 - 5. The disposal of excess excavated materials.
 - 6. Borrow of materials to make up deficiencies for embankment and other fills.
 - 7. All other incidental earthwork, all in accordance with the requirements of the Construction
 - 8. Documents.

1.02 REFERENCES

- A. Terms "Standard Specifications" refers to "Standard Specifications for Public Works Construction", Nye County Area, Nevada, (Orange Book), as currently in effect except that contractual, measurement, and payment provisions do not apply.
 - 1. Applicable sections of the Standard Specifications are:
 - a. Structure Backfill
 - b. Trench Excavation and Backfill
 - c. Aggregate Base
- B. American Society for Testing Materials (ASTM) Standards, most recent editions.

1. ASTM D 422 Method for Particle-Size Analysis of soils.
2. ASTM D 1556 Test Method for Density of Soil in Place by the Sand-Cone Method.
3. ASTM D 1557 Test Methods for Moisture-Density Relations of Soils and Soil-Aggregate Mixtures Using 10-lb. (4.5-kg) Rammer and 18-in. (457-mm) Drop.
4. ASTM D 1633 Test Method for Compressive Strength of Molded Soil-Cement Cylinders.
5. ASTM D 2167 Test Method for Density of Soil in Place by the Rubber Balloon Method.
6. ASTM D 2419 Test Method for Sand Equivalent Value of Soils and Fine Aggregate.
7. ASTM D 2487 classification of Soils for Engineering Purposes.
8. ASTM D 2901 Test Method for Cement Content of Freshly-Mixed Soil-Cement.
9. ASTM D 2922 Test Methods for Density of Soil and Soil-Aggregate in Place by Nuclear Methods (Shallow Depth).
10. ASTM D 4253 Test Methods for Maximum Index Density of Soils Using A Vibratory Table.
11. ASTM D 4254 Test Methods for Minimum Index Density of Soils and Calculation of Relative Density.

PART 2 PRODUCTS

2.01 MATERIALS

- A. Granular Backfill as specified in the Orange Book, Latest Edition.
- B. Type 2 Aggregate Base as specified in Orange Book, Latest Edition.
- C. Selected Backfill as specified in Orange Book, Latest Edition.
- D. Slurry Cement Backfill as specified in Orange Book, Latest Edition.
- E. Drain Rock and Pea Gravel as specified in Orange Book, Latest Edition.
- F. Soluble sulfate content shall be less than 0.3 percent by dry soil weight for all backfill materials.
- G. Imported material shall comply with select backfill as specified in. Imported fill from off-site areas shall be approved by a Geotechnical Engineer prior to placement.

PART 3 EXECUTION

3.01 PREPARATION

- A. Inspect and check site of excavation for correct alignment.
- B. Check location of concrete structures, curb and gutters and valley gutters, if any.

3.02 EXCAVATION

- A. Excavate pipeline location to true lines and grades as shown. Over excavate in areas under concrete structures as shown.
- B. Contractor may tunnel or bore under existing concrete curb and gutter and valley gutters, if adequate support is provided to ensure the long term integrity of the gutters. If damaged, replace a minimum of 10 linear feet of damaged curb and gutter and valley gutters.
- C. Excavate to pads, footings, road subgrade, ditches, slopes and other facilities to true lines and grades as shown.
- D. Excavation within building areas shall extend a minimum of 2 feet below the deepest footing and extend 5 feet beyond outer edges of exterior footing. Exposed soil should then be scarified minimum 8-inches and compacted to 90% RC per ASTM D1557.
- E. Trenches deeper than 5 feet shall incorporate shoring or be laid in accordance with OSHA requirements.
- F. Excess excavated material and excavated material unsuitable for backfill, as determined by Engineer, shall be removed from the site of the work and disposed of by the Contractor at his own expense, at offsite locations to be approved by the Engineer.
- G. Engineer will approve such locations only after the Contractor has made all arrangements for disposal of materials at the location and files with Engineer the written consent of the owner of the property upon which the Contractor intends to dispose of such material.
- H. The owner's consent shall contain an acknowledgment of the type of materials to be disposed of on his/her property, and required preparation of the property prior to disposal thereon, and the manner in which material is to be disposed of on the property.
- I. Arrangements for disposal of excess materials shall be the responsibility of Contractor.

3.03 EXPLOSIVES AND BLASTING

- A. Blasting will not be permitted.

3.04 BACKFILLING

- A. Before pipe installation or structure construction, bedding or base shall be placed from bottom of excavation to designed elevation.
 - 1. The material shall be either Granular Backfill or Type 2 Aggregate Base.

2. Compact backfill to at least 90 percent maximum density per ASTM D 1557.
- B. After pipe has been installed or structure constructed, backfill around the pipe and up to 12 inches above the top of the pipe with Granular Backfill. Backfill the remainder of the trench with cement slurry backfill, granular backfill, or select backfill, except that in paved areas the top 18 inches of trench shall be backfilled with Type 2 Aggregate Base backfill. Compact to minimum 90%.
- C. Slurry Cement Backfill may be required (1) where the Contractor cannot propose another method acceptable to the Engineer for establishing a stable base under curb and gutter and valley gutters where areas have been excavated by tunneling or boring under existing curb and gutter or valley gutters; (2) where shown on the Drawings.
- D. No clay material and drain backfill, known locally as pea gravel, shall be used as backfill or embankment, except where groundwater conditions exist.
- E. Where compaction in excess of 90 percent of maximum density is required or for structural backfill the Contractor shall use mechanical compaction.

3.05 FLOODING AND JETTING

- A. Flooding and Jetting will not be permitted.

3.06 EMBANKMENT

- A. Where shown on the Drawings, use selected backfill material for constructing embankments to the dimensions and side slopes shown.
- B. Perform compaction in 8-inch layers by mechanical methods to 90 percent maximum density for all embankments except under pavements and buildings.
- C. For embankment areas under pavements or buildings, perform compaction in 8-inch layers by mechanical methods to 95 percent of maximum density.

3.07 RESTORATION OF STREET SURFACING

- A. Replace all street surfacing, base and subgrade aggregate removed in connection with performing the Work in streets or rights-of-way pursuant with Nye County and the NDOT Permit requirements.

3.08 FIELD TESTING

- A. Sampling and testing of backfill material shall be done by a testing laboratory acceptable to the Engineer and all material testing shall be performed under the responsible charge of a Registered Professional Engineer.
 1. All test data submitted shall unmistakably identify the name of the testing laboratory, the location of the source of stockpiled material, the date of the sampling, the date of the tests, and shall be signed by the Registered Professional Engineer in responsible charge.

2. All samples of the proposed backfill material shall be obtained directly at the source by the testing laboratory.
 3. Engineer may determine how many and from where the test samples shall be obtained.
 4. No test data for a proposed backfill material will be accepted by Engineer unless the proposed backfill material has been sampled and tested within one year from the date of submittal.
 5. All test data required herein shall be provided at the sole cost and expense of the Contractor.
- B. Allot sufficient time during construction operations for the performance of any control testing deemed necessary by the Engineer.
1. Permit Engineer to make field density tests of any compacted backfill layer prior to placing additional backfill material.
 2. Any layer, or portion thereof, that does not meet density requirements shall be reworked and re-compacted until it does meet the specified density requirements.
- C. Tests made by Engineer for verifying compliance with backfill density requirements shall constitute the ultimate authority as to the acceptability of the backfill density. Contractor is not precluded from making or having made soil tests for his own information and satisfaction; however, except when specifically agreed to in writing by Engineer, tests made by Contractor or by any other party not authorized by Engineer shall not take precedence over test results obtained by Engineer.

3.09 PROTECTION AND RESTORATION OF EXISTING IMPROVEMENTS

- A. Protect all trees, plants and lawns that are not specified or shown on the Drawings to be removed for the performance of the Work, from injury or damage resulting from the construction operations.
- B. Signs, trees, plants and lawns which are removed, injured or damaged by the Contractor's operations shall be replaced or restored to their former state, or better, at the Contractor's expense.

END OF SECTION

SECTION 02225

TRENCH EXCAVATION AND BACKFILL

PART 1 GENERAL

1.01 DESCRIPTION

A. Description of Work

The work covered by this Section includes the furnishing of all plant, labor, tools, equipment and materials and performing all operations in connection with the excavation, trenching, backfilling, moisture conditioning, and surface repair of all pipelines, accessories and lines connected thereto, complete including sheeting and shoring, dewatering, grading and cleanup and traffic control all in accordance with these Specifications and the applicable Drawings. Excavation for appurtenant structures such as manholes, inlets, transition structures, junction structures, vaults, valve boxes, catch basins, etc. shall be included in this Specification.

B. Related Work Specified Elsewhere

1. Earthwork.....Section 02200
2. Sanitary Sewer Pipe.....Section 02401

C. Definitions

1. Trench – An excavation in which the depth is greater than the width of the bottom of the trench.
2. Foundation – Material on which pipe bedding or structure is to be directly placed.
3. Bedding – Granular material that surrounds pipe or structure. Pipe bedding shall extend 4" above the pipe.
4. Maximum Density – The maximum density as determined by ASTM D1557 for the soil or aggregate under consideration.
5. Backfill – Material from top of bedding to finish subgrade or finish grade.

1.02 QUALITY ASSURANCE

A. Provisions of Testing

1. All testing for compaction will be provided by the Owner. The Contractor shall be responsible for the cost of any retests required due to failed tests.

B. Testing Methods

1. ASTM C94, Standard Specification for Ready-Mixed Concrete

2. ASTM C117, Standard Test Method for Materials Finer than No. 200 Sieve by Washing.
3. ASTM C131, Standard Test Method for Resistance to Degradation of Small Size Coarse Aggregate by Abrasion and Impact in the Los Angeles Machine.
4. ASTM C136, Standard Method for Sieve Analysis of Fine and Coarse Aggregate.
5. ASTM D 1556 Test Method for Density of Soil in Place by the Sand-Cone Method.
6. ASTM D 1557 Test Methods for Moisture-Density Relations of Soils and Soil-Aggregate Mixtures Using 10-lb. (4.5-kg) Rammer and 18-in. (457-mm) Drop.
7. ASTM D2922, Density of Soil and Soil-Aggregate in Place by Nuclear Methods.
8. ASTM D3017, Moisture Content of Soil and Soil-Aggregate in Place by Nuclear Methods.

1.03 FREQUENCY OF TESTING

A. Maximum Dry Density and Optimum Moisture Content, ASTM 1557

1. Request one test for each different class or type of material, and
2. Request one test when previous test is suspect, due to subtle changes in the material, as determined by the Engineer.

B. Density of Soil In-Place by Sand Cone or Nuclear Methods

1. Request a minimum of one test per lift per 500 linear feet of trench.
2. The Engineer may test more or less frequently as he deems appropriate

1.04 TESTING TOLERANCES

A. Percent Compaction.

1. Not less than as specified on Plans or in these Specifications.

B. Place Moisture Content as required to achieve minimum compaction requirements.

C. Soft or Yielding Surfaces.

1. Regardless of percent compaction obtained by test, areas that are soft and yield under the load of construction equipment ("pumping") are to be removed and replaced at no additional cost.

1.05 SUBMITTALS

A. Test Results

1. Provide moisture-density curves and gradations for bedding material per ASTM D1557, ASTM C131 and ASTM C136.

1.06 JOB CONDITIONS

A. Soils Report

1. The Owner is responsible for providing a soils report for this Project. It is recommended that the Contractor carefully review this report prior to construction on the Project.

PART 2 PRODUCTS

2.01 MATERIALS

A. Unsuitable material not to be incorporated in the work include:

1. Organic matter such as peat, mulch, organic silt or sod
2. Expansive clays
3. Material containing excessive moisture
4. Poorly graded coarse material
5. Rock or particle size in excess of 6 inches
6. Material that will not achieve density and/or bearing requirements
7. Construction debris such as broken concrete or asphalt concrete.

B. Bedding

1. Bedding shall be a graded material conforming to one of the following grading requirements:

Class	Sieve Size	Percent by Weight Passing Sieve
Class A	3/8 inch	100
	No. 4	90-100
	No. 50	10-40
	No. 100	3-20
	No. 200	0-15
Class B	1/2 inch	100
	No. 4	0-15
	No. 200	0-3
Class C	1 inch	100
	3/4 inch	90-100

	3/8 inch	10-55
	No. 4	0-10
	No. 200	0-2

C. Class E Backfill.

1. Class E Backfill shall be native excavated material or approved import material free from unsuitable materials defined herein.

D. Portland Cement Concrete

1. ASTM C94, 4,000 psi yield strength minimum.

E. Foundation

1. The Contractor may use any aggregate material that is free from unsuitable material for pipe foundation provided that a suitable foundation can be constructed with the material provided.

F. Type 2 Class B Aggregate Base

1. Type 2, Class B Aggregate Base shall conform to the following:

a. ASTM C136

Sieve Size	Percent by Weight Passing Sieve
1 inch	100
3/4 inch	90-100
No. 4	35-65
No. 16	15-40
No. 200	2-10

b. Plastic Limits according to ASTM D4318

Percentage by Weight Passing #200 Sieve	Plastic Limit of material finer than #40 Sieve
0.1 to 3.0	15
3.1 to 4.0	12
4.1 to 5.0	9
5.1 to 8.0	6
8.1 to 11.0	4

c. Other Requirements:

- 1) Percentage of Wear, ASTM C131 43 Percent Max.
- 2) Liquid Limit, ASTM D4318 35 Max.

3) Resistance "R" Value, Nev. T233

70 Min.

PART 3 EXECUTION

3.01 INSPECTION BY CONTRACTOR

- A. Verify all preliminary work including construction staking has been performed in accordance with the Plans and these Specifications.

3.02 EXCAVATION

A. General

- 1. Perform all excavations of every description and of whatever substances encountered to the depths indicated on the Plans, including excavation ordered by the Owner of compacted fill for the purpose of performing tests. Use open cut excavation methods unless otherwise shown on the Plans or approved by the Engineer. Remove all loose material after excavation or compact to 90% maximum density prior to placing bedding.

B. Trench Widths

- 1. Excavate trenches for pipe to the dimensions indicated on the Plans.
- 2. Maintain trench walls as vertical as possible except as required by safety standards and for that required for sheeting and shoring. If the maximum trench width is exceeded at the top of the pipe, provide necessary additional load bearing capacity by means approved by the Owner at the Contractor's expense.

3.03 OVER-EXCAVATION

A. Unauthorized Over-excavation.

- 1. Fill and compact unauthorized beyond the specified grade line, at the contractor's expense, with aggregate base or bedding material.
- 2. Compact to 95 percent of the maximum density.

B. Rock

- 1. Over-excavate rock encountered in trench to provide a minimum of four inches of bedding below the pipe and the minimum width at the springline.

C. Unsuitable Material.

- 1. Over-excavate unsuitable material to the depth required as determined by the Owner to provide required support.
- 2. Backfill the over-excavation with bedding and compact to at least 95% of the maximum density.

3. Foundation material may be used for stabilization below the bedding zone.

3.04 EXCAVATION FOR MANHOLES, VALVES AND OTHER ACCESSORIES

- A. Provided excavated surfaces are firm and unyielding, the Contractor may elect to cast concrete for the structure directly against excavated surfaces. Over-excavate to provide foundation or bedding material where required or indicated on the Plans.

3.05 GRADING AND STOCKPILING

A. Grading.

1. Grade in the vicinity of the trench to prevent surface water from flowing into the trench.
2. Remove any water accumulated in the trench by pumping or other approved methods.
3. Stockpile excavated material in an orderly manner a sufficient distance back from the edges of the trench to avoid overloading and to prevent slides or cave-ins.

B. Topsoil.

1. Excavate topsoil and stockpile separately.
2. Replace topsoil upon completion of backfill to the elevation and grade indicated on the Plans

3.06 SHORING AND SHEETING

- A. Shore, sheet and brace excavations as set forth in the rules, orders and regulations of the United States Department of Labor Occupational Health and Safety Administration (OSHA).
- B. Provide detailed plans and calculations prepared by a Nevada-registered professional engineer for excavations twenty feet (20') in depth or greater or when shoring, sheeting or bracing deviates from OSHA standards.
- C. Place and remove shoring, sheeting and bracing so as no to damage adjacent improvements, utilities or utility being placed.
- D. Costs for shoring, sheeting and bracing shall be incidental to the pipe items.

3.07 OPEN TRENCH

A. Maximum Length.

1. The maximum length of open trench in the aggregate at any one location is not to exceed 500 feet.
2. The trench is open until fill is completed to adjacent finish grade elevation.

B. Temporary Provisions.

1. Furnish and install trench bracing and steel plating required to provide safe and convenient vehicular and pedestrian passage across trenches where required.
2. Maintain access to emergency facilities at all times.

3.08 AGGREGATE BASE

- A. Place the aggregate base upon backfill and embankments as indicated on the Plans.
- B. Grade the base to provide the depth and dimensions shown on the Plans.
- C. Compact the aggregate base to 95% of the maximum value determined by ASTM D1557.

3.09 FOUNDATION, BEDDING, BACKFILLING AND COMPACTION

A. Foundation.

1. Place foundation when soils in the trench bottom are soft or yielding.
2. It is anticipated that foundation could be necessary in areas where groundwater is present or near the trench bottom.
3. Costs associated with dewatering and foundation shall be considered incidental to the pipe item.

B. Fine Grading.

1. Accurately grade the bottom of the trench to provide uniform bearing and support for each section of pipe at every point along its entire length.

3.010 MOISTURE CONDITIONING

- A. Moisture condition all bedding and backfill materials by aerating or wetting to achieve the moisture content required to obtain the minimum percent compaction.
- B. Mix until the moisture content is uniform throughout the lift.
- C. No additional payment will be made for moisture conditioning, import or native materials.

3.011 LIFT THICKNESS

Lift Description	Maximum Loose Lift Thickness, Inches
Bedding	6
Backfill	8
Aggregate Base Surfacing	6

- A. Lift thickness may be increased if Contractor can demonstrate through a series of density tests that minimum density is achieved throughout the lift thickness.

3.012 COMPACTION

A. Compaction Methods.

- 1. Water consolidation, water jetting or rubber tired tractor wheel rolling will not be allowed.

B. Pipe Haunch.

- 1. Hand compact initial backfill in pipe haunch with a hand compactor (J-bar) or a mechanical vibratory compactor sized to fit the narrow width between the trench wall and pipe.
- 2. Give special attention to provide proper compactive effort in the important pipe haunch zone.

C. Compaction Densities.

- 1. Thoroughly compact trench bedding and backfill to not less than the percent compaction indicated on the Plans.
- 2. Where not indicated on the Plans, compact bedding to 95% and backfill to 90%.

3.013 BACKFILL FOR MANHOLES, VALVES, MINOR STRUCTURES AND OTHER

A. Backfill appurtenances and structures as shown on the Plans.

- B. Where not clearly indicated, the backfill including bedding, backfill lift, lift thickness, and compaction, shall be identical to the adjacent trench detail.

3.014 SURFACE RESTORATION

A. Grading.

- 1. Perform all grading adjacent to backfilled trenches and structures as necessary.
- 2. Leave the area in a neat and satisfactory condition.
- 3. Grade area to provide proper drainage and to ensure that the existing drainage has not been changed.

B. Surface Restoration.

- 1. Resurface as specified or to match all existing surfaces broken or damaged by the installation of the new work.

- C. Clean up remove all excess soil, concrete, etc. from the premises. Leave job site in a neat and clean conditions.

3.015 PROTECTION AND RESTORATION OF EXISTING IMPROVEMENTS

- A. Protect all trees, plants and lawns that are not specified or shown on the Drawings to be removed for the performance of the Work, from injury or damage resulting from the construction operations.
- B. Signs, trees, plants and lawns which are removed, injured or damaged by the Contractor's operations shall be replaced or restored to their former state, or better, at the Contractor's expense.

END OF SECTION

SECTION 02401

SANITARY SEWER PIPE

PART 1 GENERAL

1.01 DESCRIPTION

- A. The WORK under this Section includes providing all labor, materials, tools and equipment necessary for furnishing and installing sanitary sewer pipe, in accordance with these Specifications and the Plans or established by the ENGINEER.
- B. This WORK includes furnishings and installing connecting bands, branch connections, elbows or other fittings, and all appurtenances required to complete the sanitary sewer.

1.02 SUBMITTALS

- A. Sanitary Sewer Pipe: Material certifications stating conformance with the requirements of this Section.
- B. Submittal shall be delivered to Engineer in accordance with Section 01300 - Submittals of the Technical Specifications.

1.03 REFERENCES

- A. ASTM D2680 Standard Specification for Acrylonitrile-Butadiene-Styrene (ABS) and Poly(Vinyl Chloride) (PVC) Composite Sewer Piping
- B. ASTM D2751 Standard Specification for Acrylonitrile-Butadiene-Styrene(ABS) Sewer Pipe and Fittings
- C. ASTM D3034 Standard Specification for Type PSM Poly(Vinyl Chloride) (PVC) Sewer Pipe and Fittings
- D. ASTM D3350 Standard Specification for Polyethylene Plastics Pipe and Fittings Materials
- E. ASTM F 679 Standard Specification for Poly(Vinyl Chloride) (PVC) Large-Diameter Plastic Gravity Sewer Pipe and Fittings
- F. ASTM F714 Standard Specification for Polyethylene (PE) Plastic Pipe (SDR-PR) Based on Outside Diameter
- G. ASTM D3212 Standard Specification for Joints for Drain and Sewer Plastic Pipes Using Flexible Elastomeric Seals
- H. Orange Book Standard Specifications for Public Works Construction, Regional Transportation Commission of Washoe County et al., 1996 Edition and current revisions.

PART 2 PRODUCTS

2.01 PVC SEWER PIPE

- A. PVC Sewer Pipe, four inches through 15 inches in diameter, inclusive, shall have a standard dimension ratio (SDR) of 35, and conform to ASTM D 3034. Before any PVC pipe is used on this project, the CONTRACTOR shall supply certifications, signed by an authorized agent of the seller or manufacturer, stating that the material has been sampled, tested, and inspected in accordance with ASTM D 3034.
- B. PVC Sewer Pipe greater than 15 inches in diameter shall conform to ASTM F 679. Before any PVC pipe is used, the CONTRACTOR shall supply certifications, signed by an authorized agent of the seller or manufacturer, stating that the material has been sampled, tested, and inspected in accordance with ASTM F 679.
- C. The pipe shall have integral wall bell and spigot joints conforming to ASTM D 3212. The bell shall consist of an integral wall section with a solid cross-section elastomeric ring, factory assembled, securely locked in place to prevent displacement.
- D. Flexible water-tight connections, approved by the ENGINEER, shall be used at PVC pipe connections to manholes and other rigid structures.

2.02 UNDERGROUND MARKING TAPE

- A. Underground marking tape shall be green, at least four (4) inches wide, four mil thick, polyethylene tape, with a metallic backing capable of being traced with locators. The tape shall have black letters with the following wording: "Caution: Sewer Line Buried Below" in letters a minimum 1-1/4" tall. The marking tape shall be installed 12 inches above the top of all sewer mains and services.

PART 3 EXECUTION

3.01 CONSTRUCTION

- A. Excavation, bedding, and backfill shall conform to the requirements of Section 02225 – Trench Excavation and Backfill. Underground marking tape shall be installed as shown on the plans.
- B. Sheeting and bracing required for trenches shall be removed to the elevation of the conduit, but no sheeting will be allowed to be pulled, removed, or disturbed below the conduit. Sheeting and bracing shall meet OSHA requirements.
- C. Before lowering into the trench, the pipe shall be inspected for defects. All cracked, chipped, or broken pipe shall be discarded. The ends and interior of the pipe shall be clean. Belled ends shall be laid upgrade. Handling of the pipe shall be accomplished in a manner that will not damage the pipe. The joint shall be made in the manner recommended by the manufacturer. Care shall be taken not to buckle or disturb previously laid pipe.

- D. Pipe shall be laid accurately to the staked line and grade. All service connections shall be installed as indicated on the Drawings. Where existing service sewers are to be connected, suitable fittings and adapters shall be provided by the CONTRACTOR.
- E. Pipe shall be cleaned of all foreign matter, and water shall be kept out of trenches until joints have been completed. When WORK is not in progress, open ends of pipe and fittings shall be securely closed to keep foreign matter and animals from entering.
- F. Each joint shall be inspected to ensure that it is properly made before backfilling is done. Care shall be taken to prevent any dirt or foreign matter from entering the open end of the pipe. Where it is necessary to cut pipe, such cuts shall be neatly made in an approved manner. The laid pipe shall be true to line and grade and, when completed, the sewer shall have a smooth and uniform invert. No section of gravity sewer, including service connections shall have an adverse grade which would pond water in the invert of the sewer.
- G. Connections to existing sewer mains, service connections, and manholes shall be made in such a manner so as to not damage the existing facility. Such connections shall be made so that no projections or rough surfaces occur within the pipe.
- H. If the CONTRACTOR believes that the WORK at the new location(s) will result in a substantive change, the CONTRACTOR shall notify the ENGINEER prior to beginning the changed WORK. The ENGINEER will evaluate the request and if the relocation is warranted, the change in WORK shall be authorized.
- I. Where gravity flow sanitary sewers cross above or less than 18 inches below waterlines, or approximately parallel water lines within ten feet horizontally, the sewer pipe shall meet the requirements Nevada Administrative Code sections 445A.6715 through 445A.67175.

3.02 TESTING

- A. Prior to testing all manholes, all sections of pipe shall be cleaned using an inflatable rubber ball of a size that will inflate to fit snugly into the pipe. The ball may, at the option of the CONTRACTOR, be used without a tag line; or a rope or cord may be fastened to the ball to enable the CONTRACTOR to know and control its position at all times. The ball shall be placed in the last clean out or manhole on the pipe to be cleaned, and water shall be introduced behind it. The ball shall pass through the pipe with only the force of the water impelling it. All debris flushed out ahead of the ball shall be removed at the first manhole where its presence is noted. In the event cemented or wedged debris, or a damaged pipe, stops the ball, the CONTRACTOR shall remove the obstruction and make any necessary repairs in a manner that is acceptable to the ENGINEER. Any alternate methods of cleaning sewers shall be submitted to the ENGINEER for approval, and shall not be used unless approved.
- B. Prior to testing, the sewer shall be complete with laterals, and trenches shall be fully backfilled and compacted to finish grade, or, if the sewer is under pavement, finish pavement subgrade.
- C. For WORK involving placement of new sanitary sewer collection systems, all sections of pipe shall be tested for leakage using the Exfiltration Test for either air or water as specified hereafter; or, at the sole direction of the ENGINEER, when the normal water table is above the sewer throughout the section under test, the ENGINEER may permit use of the Infiltration Test procedure specified hereafter. Where leakage is in excess of the specified

rate, the sewer shall be repaired by the CONTRACTOR as required to comply with the leakage test requirements. The ENGINEER may require the CONTRACTOR to repair obvious leaks even though the total length of the test section falls within the maximum allowable leakage for the test used.

- D. For WORK involving replacement of existing, active sanitary sewer collection systems, and the new system is not put into service during the same work shift, no Exfiltration/ or Infiltration Tests will be required.
- E. Defective pipe joints shall be repaired in a manner that the repaired pipe joint will have some flexibility and the effectiveness of the repair will not be affected by differential movement of the adjoining pipes. A Fernco Coupling as per the Standard Details, or approved equal, will be acceptable in making such repairs.
- F. The CONTRACTOR will make one complete TV inspection after all sewers have passed the specified watertightness test. All defects regarding sewer alignment and grade, damaged pipe, and visible leaks observed during this inspection, shall be corrected by the CONTRACTOR. The CONTRACTOR shall de-water the sewers as required for the performance of the TV inspection work by the ENGINEER. The CONTRACTOR shall be responsible for all costs associated with any TV inspection required following the initial TV inspection, if any defects were observed during this or any subsequent TV inspections.
- G. Pressure and leakage testing for the pressurized sewer force main shall be conducted in accordance with Section 02675.

3.03 FILTRATION TEST FOR GRAVITY SEWER PIPES (USING AIR)

- A. The CONTRACTOR shall furnish all facilities and personnel for conducting the test under the observation of the ENGINEER. The equipment and personnel shall be subject to the approval of the ENGINEER. Joints only may be tested in pipe 36 inches in diameter or larger, at the option of the CONTRACTOR.
- B. Immediately following the pipe cleaning, the pipe installation shall be tested with low pressure air. Air shall be slowly supplied to the plugged pipe installation until the internal air pressure reaches five pounds per square inch greater than the average back pressure of any ground water that may submerge the pipe. At least two minutes shall be allowed for temperature stabilization before proceeding further.
- C. The pipeline shall be considered acceptable when tested at an average pressure of four psi greater than the average pressure of any ground water that may submerge the pipe if the section under test does not lose air at a rate greater than 0.0030 cubic feet per minute per square foot of internal surface.
- D. The requirements of this Specification shall be considered satisfied if the time required for the pressure to decrease from 4.5 psi to 3.5 psi above average ground water pressure is greater than that shown on the following table:

**TIME FOR PRESSURE TO DROP FROM
4.5 TO 3.5 PSI ABOVE AVERAGE GROUND WATER PRESSURE**

Pipe Diameter	Minutes	Seconds
8"	3	57
10"	4	43
12"	5	40
15"	7	5
18"	8	30
24"	11	20
30"	14	10

E. For other sizes, determine test time using the following formula:

$$T = 28.33 D$$

Where T = time in seconds
D = pipe diameter in inches

- F. For pipes 36 inches in diameter, or larger, if individual joints are tested, they shall hold six psi air pressure over the average back pressure of any ground water for a minimum time of 15 seconds.
- G. Pressure gauges should be incremented in not more than one-half pound increments for accurate tests.
- H. Braces shall be required to hold plugs in place and to prevent the sudden release of the compressed air. Due to the large forces that could be exerted by an escaping plug during the testing of the pipe, no one shall be allowed in the manholes in which plugs have been placed while tests are being conducted. The CONTRACTOR's testing equipment shall have a pressure relief device that will prohibit the pressure in the pipeline from exceeding ten pounds per square inch.

3.04 EXFILTRATION TEST FOR GRAVITY SEWER PIPES (USING WATER)

A. Where groundwater is below the pipe to be tested, a minimum head of eight feet of water above the crown at the upper end of the test section shall be maintained for a period of four hours, during which time it will be presumed that full absorption of the pipe body has taken place, and thereafter for a further period of one hour for the actual test of leakage. During this one hour period, the measured loss shall not exceed the rate given below:

Type of Pipe	Allowable Exfiltration Rate
Ductile Iron	E = 0.00008 DL
PVC	E = 0.0004 DL

E = Allowable leakage in gallons per hour
D = Nominal inside diameter of pipe in inches
L = Length of pipe being tested in feet

- B. Where groundwater is above any pipe to be tested, the minimum head of the test will be raised to provide an elevation head of eight feet above the groundwater.
- C. The maximum length of sewer in any test section shall be 500 feet.

3.05 INFILTRATION TEST FOR GRAVITY SEWER PIPE

- A. Infiltration testing may be allowed at the ENGINEER's option when the natural ground water table is above the crown of the higher end of the test section and the external water pressure exerted on the pipe is equivalent to the exfiltration test. The maximum allowable limit for infiltration shall be as determined by the formulas defined in the above section Exfiltration Test (Using Water).

END OF SECTION

SECTION 02601

MANHOLES

PART 1 GENERAL

1.01 GENERAL

- A. Except as otherwise permitted herein, manholes shall be constructed of precast, reinforced concrete sections on either precast or cast-in-place, reinforced concrete bases. Manholes shall conform to the size, shape, form and details shown on the Plans.

PART 2 PRODUCTS

2.01 PRECAST CONCRETE SECTIONS

- A. All precast cylinder units, precast concrete taper sections and precast base units shall meet the strength requirements for a Precast Reinforced Concrete Manhole Risers and Tops, ASTM C 478. Design and manufacture shall be based on H20 loading. Precast manholes shall be as manufactured by Jensen Precast Inc., or by an approved manufacturer. The Contractor shall submit shop drawings of the precast manhole units he proposes to use.
- B. All concrete manholes shall be inspected by an independent, certified testing laboratory, approved by the City, to establish the strength of the concrete and the adequacy of curing to certify the date that the manholes were cast and to confirm that the steel has been properly placed, all in accordance with the Plans and Specifications. The cost of these tests shall be included in the various unit price Contract Items and no special payment will be made therefore. This testing shall be performed by the laboratory at the contractor's manufacturing plant, prior to shipment.
- C. At least three cylinders shall be taken each day that manholes are cast, with batch samples to be designated by the laboratory representative. At least one set of cylinders shall be taken for each nine cubic yards of concrete used in the construction of the manhole sections. These samples shall be tested for strength. If the samples fail to meet minimum concrete strength requirements set forth in the Specifications, all manhole sections manufactured from the concrete from which the cylinders were made will be considered rejected.
- D. In addition, the Owner reserves the right to core manholes either at the site or point of delivery to validate strength of concrete and placement of steel. If cores fail to demonstrate the required strength or indicate incorrect placement of reinforcing steel, all sections not previously tested will be considered rejected until sufficient additional cores are tested, at the Contractor's expense, to substantiate conformance to these requirements.

2.02 CONCRETE (CAST-IN-PLACE BASES)

A. Curing

1. All precast concrete manhole sections shall be cured in accordance with any one of the methods specified in ASTM 478. The facilities for curing shall, however, be subject to the review and prior approval of the Engineer. No precast concrete manhole sections shall be delivered to the job site until the specified minimum comprehensive strength of 4,000 psi, as determined by crushing tests on cured concrete cylinders, has been obtained.
2. All cast-in-place concrete manhole bases shall be covered and protected from freezing temperatures.

B. Frames and Covers

1. Manhole frames and covers shall be of gray iron, shall meet the requirements ASTM A48-30 and shall conform to the details shown on the Plans.

C. Joint Sealing Compound

1. Precast manhole sections shall be jointed with a preformed joint sealing compound, manhole joint sealant by Jensen Precast Inc., or equivalent, applied in accordance with the manufacturer's instructions.

D. Drop Manhole

1. Drop manholes shall be constructed at the location and in conformance with the details shown on the Plans. Materials and construction of drop manholes shall conform in all respects to the applicable provisions of these Specifications for standard precast manholes (including frames and covers), with modifications for the addition of drop inlet pipe of the diameter noted on the Plans or these Specifications.
2. Drop connections shall be built along the line of the pipe at the points indicated on the Plans. They shall be of precast concrete construction conforming to the Specifications for precast concrete manhole construction.
3. Fittings for drop sewer connections shall be furnished and set in the manner shown on the Plans. In all drop sewer connections. The drop tee and other fittings shall be of polyvinyl chloride pipe encased in concrete as shown on the Plans.

PART 3 EXECUTION

3.01 TRANSPORTATION AND DELIVERY

- A. Every precaution shall be taken to prevent injury to the precast manhole sections during the transportation and unloading of the sections. The precast sections shall be unloaded using skids, pipe hooks, rope slings, or suitable power equipment, if necessary, and the sections shall be under perfect control at all times. Under no conditions shall the precast sections be dropped, dumped or dragged.
- B. If any precast section is damaged in the process of transportation, or handling, such section shall be rejected and immediately removed from the site and replace at the Contractor's expense.

3.02 EXCAVATION AND BACKFILL

- A. Excavation and backfill shall be done in accordance with the Specifications.

3.03 CAST-IN-PLACE BASES

- A. Manhole bases shall be constructed of Class A concrete to the form and dimension shown on the detailed Plans. Said concrete bases shall be formed and poured on undisturbed soil and/or on pipe bedding material. That portion of the base above the invert elevation of the sewer pipe shall be formed to provide a smooth channel section as shown on the Plans. The forms shall be checked and approved by the Engineer for accuracy of dimensions and relative smoothness prior to pouring the base. Channels shall vary uniformly in size and shape from inlet to outlet if required. The manhole base shall be poured as one monolithic pour.
- B. Joint Sealing Compound
 1. The sealing compound shall be applied as follows:
 2. The joint shall be cleaned with a brush.
 3. The silicon treated protective paper shall be removed from one side of the preformed rope and reformed rope shall be laid paper side up on the cleaned joint surface. The surface shall be pressed firmly end-to-end around the entire joint making 1-inch laps where necessary.
 4. The protective paper shall be removed from the preformed rope and the next section shall be lowered into place.
 5. Sufficient preformed joint sealing compound shall be installed so as to completely fill the joint and show a squeeze-out on the inside and outside of the joint.
- C. Pipe and Fittings

1. All sewer pipe and fittings, including installation at manholes shall conform to the provisions of the specifications of the designated pipe and fittings.

D. Elevation and Installations

1. Each manhole section shall be set perfectly plumb. Section of various heights shall be used in order to bring the top of the manhole ring and cover to the required elevation.
2. The elevations at which manhole frames and covers are to be set shall conform to the requirements set forth on the Plans, but in all cases shall be governed by the Engineer in the field. Manhole frames shall be set at the required grade and shall be securely attached to the top precast manhole shaft unit.

E. Cleaning

1. All manholes shall be thoroughly cleaned of any accumulation of silt, debris, or foreign matter of any kind, and shall be clear of such accumulations at the time of final acceptance.
2. Frames and covers shall be cleaned of foreign matter to ensure a satisfactory fit and appearance prior to final acceptance.

F. Testing

1. It is the intent of the Plans and Specifications that manholes and appurtenances be as watertight and free from infiltration as possible. The adequacy of manholes and appurtenances as to watertightness shall be determined by plugging the sewer pipes and filling the manhole with water. Any evidence of leakage as a result of testing shall be repaired to the satisfaction of the Engineer at the sole expense of the Contractor. When manhole hydrostatic testing is ordered by the Engineer, it shall be at the sole expense of the Contractor.

END OF SECTION

SECTION 02621

GENERAL PIPING SYSTEM AND APPURTENANCES

PART 1 GENERAL

1.01 DESCRIPTION

- A. This section describes the requirements and procedures for piping systems (pressure pipe and gravity pipe) and appurtenances that apply to a number of other complimentary Specification Sections. The items are listed in this section to avoid repetition in sections elsewhere. This section includes, but is not limited to, temporary pipelines, wet taps, flexible pipe couplings, grooved and shouldered end couplings, joint restraint system, field touch up, bolts, nuts, polyethylene wrap, warning/identification tape, tracer wire, gate well and extension stems, meter boxes, abandonment and removal of existing facilities, salvage, and disposal.

1.02 REFERENCE STANDARDS

The publications listed below form part of this specification to the extent referenced and are referred to in the text by the basic designation only. Reference shall be made to the latest edition of said standards unless otherwise called for.

1. AWWA C105 - Polyethylene Encasement for Ductile-Iron Pipe Systems
2. AWWA C111 - Rubber Gasket Joints for Ductile-Iron Pressure Pipe and Fittings
3. AWWA C200 - Steel Water Pipe - 150 mm (6") and Larger
4. AWWA C203 - Coal-Tar Protective Coatings and Linings for Steel Water Pipelines - Enamel and Tape - Hot Applied
5. AWWA C213 - Fusion-Bonded Epoxy Coating for Interior and Exterior of Steel Water Pipelines
6. AWWA C606 - Grooved and Shouldered Joints
7. AWWA C900 - PVC Pressure Pipe, 100 mm (4") Through 300 mm (12") for Water Distribution
8. AWWA C901 - Polyethylene (PE) Pressure Pipe and Tubing 1/2" (13 mm) Through 3" (76 mm)
9. AWWA C906 - Polyethylene (PE) Pressure Pipe and Tubing 4" (100 mm) Through 65" (1,650 mm)
10. AWWA M11 - Steel Pipe - A Guide for Design and Installation
11. AWWA - Guidelines for Distribution of Non-potable Water

12. ASTM A 36/A 36M -Standard Specification for Carbon Structural Steel
13. ASTM A 47/A 47M - Standard Specification for Ferritic Malleable Iron Castings
14. ASTM A 53 - Standard Specification for Pipe, Steel, Black and Hot-Dipped, Zinc-Coated Welded and Seamless
15. ASTM A 108 - Standard Specification for Steel Bars, Carbon, Cold Finished, Standard Quality
16. ASTM A 183 - Standard Specification for Carbon Steel Track Bolts and Nuts
17. ASTM A 283/A 283M - Standard Specification for Low and Intermediate Tensile Strength Carbon Steel Plates, Shapes and Bars
18. ASTM A 307 - Standard Specification for Carbon Steel Bolts and Studs
19. ASTM A 325/A 325M - Standard Specification for High-Strength Bolts for Structural Steel Joints
20. ASTM A 510/A 510M - Standard Specification for General Requirements for Wire Rods and Course Round Wire, Carbon Steel
21. ASTM A 512 - Standard Specification for Cold-Drawn Buttweld Carbon Steel Mechanical Tubing
22. ASTM A 536 - Standard Specification for Ductile Iron Castings
23. ASTM A 568/A 568M - Standard Specification for Steel, Sheet and Strip, Carbon, Hot-Rolled, Structural Quality and Cold Rolled
24. ASTM D 2000 - Standard Classification System for Rubber Products in Automotive Applications
25. ASTM F 593 - Specifications for Stainless Steel Bolts, Hex Cap Screws, and Studs
26. ASTM F 594 - Specification for Stainless Steel Nuts
27. ANSI B1.1 - Unified Inch Screw Threads
28. ANSI B1.2 - Gages and Gauging for Unified Inch Screw Threads
29. NSF - National Sanitation Foundation
30. SSPWC - Standard Specifications for Public Works Construction ("Orangebook")

1.03 RELATED WORK SPECIFIED ELSEWHERE

- A. Specifications 02225, 02401, and 11311.

1.04 LINING CONTAMINATION PREVENTION

- A. Volatile organic compounds present in the linings of items in contact with potable water or recycled water shall not exceed concentrations allowed by the latest requirements of the State Office of Drinking Water and Department of Health Services. Some products and materials may also require proof of NSF certification on the lining materials to be used.

1.05 TEMPORARY PIPELINES

- A. Temporary pipelines, where shown on the Approved Plans or required by the Engineer, shall be furnished, installed, disinfected, connected, maintained, and removed by the Contractor. The Contractor shall perform bacteriological sampling and testing. The contractor shall provide a submittal to the Owner showing pipe layout, materials, sizing, flow calculations, schedule and duration of use, and disinfection for all temporary piping. The submittal shall be reviewed and approved by the Engineer prior to ordering or delivery of any materials.

1.06 PIPE TAPPING (WET TAP)

- A. All pipe tap (wet tap) connections to existing pipelines, whether for mainline extensions or service laterals, shall be performed by the Contractor. The Contractor shall provide materials and labor to excavate, pour thrust block, backfill, compact, and repair pavement as indicated in this Section.

1.07 JOINT RESTRAINT SYSTEM

- A. Joint Restraint Systems may be used for PVC or ductile-iron pipe only with prior approval of the Engineer. Joint restraint systems shall be used in the place of, or in conjunction with, concrete thrust blocks as directed. Contractor shall submit shop drawings, calculations, and catalog data for joint restraint systems.
- B. Splined gaskets, also known as joint restraint gaskets, may be used for PVC or ductile-iron pipe located within casings, or for PVC pipe casings, only with prior approval of the Engineer.

1.08 POLYETHYLENE ENCASEMENT

- A. Polyethylene encasement shall be used for all ferrous metal materials not otherwise protectively coated.
- B. Polyethylene wrap shall be used for the protection of buried ductile-iron fittings and valves.
- C. Polyethylene sleeves shall be used for the protection of buried ductile iron pipe.
- D. Polyethylene wrap or sleeves may also be installed around buried PVC pipe for recycled water identification.

1.09 WARNING/IDENTIFICATION TAPE

- A. Warning/identification tape shall be installed to identify location of underground utilities and to act as a warning against accidental dig-ins of buried utilities. Warning/identification tape shall be used on all underground water and recycled water mains, potable and recycled water

irrigation systems, sewer mains, and all related appurtenances. Warning/identification tape shall also be used on cathodic protection wiring systems and tracer wire brought into and out of access ports.

1.10 TRACER WIRE

- A. Tracer wire shall be installed on all buried water and recycled water mains for the purpose of providing a continuous signal path used to determine pipe alignment after installation. Tracer wire is not required in installation of sewer mains.

1.12 VALVE STEM EXTENSION

- A. Valve Stem Extensions shall be installed when the valve-operating nut is more than 1.5m (5') below grade. Stem extensions shall be of sufficient length to bring the operating nut to a point between 300mm (12") and 450mm (18") below the gate well lid.

1.14 RECYCLED WATER IDENTIFICATION

- A. Facilities installed for the use of recycled water shall be identified with purple color coating, identification labels, or signs.

1.15 CURB IDENTIFICATION MARK FOR SERVICES

- A. The Contractor shall mark the location of all potable water, recycled water and sewer laterals at the curb crossing by stamping the face of the curb in 50mm (2") high letters as described below:
- B. Potable water laterals shall be stamped with a letter "W".
- C. Recycled water laterals shall be stamped with a letter "RW".
- D. Sewer laterals be stamped with a letter "S".

PART 2 MATERIALS

2.01 TEMPORARY PIPELINES

- A. Temporary piping layout, materials and appurtenances shall be as indicated on the approved submittal.

2.02 FLEXIBLE MECHANICAL PIPE COUPLINGS

- A. Flexible mechanical pipe couplings shall be in accordance with the Approved Materials List and as described below:
- B. Steel Couplings shall have middle rings made of steel conforming to ASTM A 36/A 36M, A 53 (Type E or S), or A 512 having a minimum yield strength of 207 MPa (30,000 psi). Follower rings shall be ductile-iron per ASTM A 536, or steel per ASTM A 108, Grade 1018 or ASTM A 510, Grade 1018. Minimum middle ring length shall be 175 mm (7") for pipe sized 150 mm (6") through 600 mm (24").

- C. Sleeve bolts shall be made of stainless steel per ASTM A193 and shall have a minimum yield strength of 276 MPa (40,000 psi), an ultimate yield strength of 414 MPa (60,000 psi), and shall conform to AWWA C111.

2.03 GROOVED END OR SHOULDERED COUPLINGS FOR DUCTILE IRON OR STEEL PIPE

- A. Grooved end or shouldered couplings shall be in accordance with the Approved Materials List and as described below:
- B. Use square-cut shouldered or grooved ends per AWWA C606. Grooved-end couplings shall be malleable iron per ASTM A 47, or ductile iron per ASTM A 536. Gaskets shall be per ASTM D 2000.
- C. Bolts in exposed service shall conform to ASTM A 183, 69 MPa (10,000 psi) tensile strength.

2.04 JOINT RESTRAINT SYSTEM

- A. Joint Restraint Systems shall be ductile-iron and shall consist of a split-ring restraint with machined (not cast) serrations - on the inside diameter, a back-up ring, and connecting bolts, and shall be selected from the Approved Materials List. Splined gaskets, also known as joint restraint gaskets, shall be a rubber-ring type with stainless steel locking segments vulcanized into the gasket.

2.05 FIELD TOUCH-UP APPLICATIONS

- A. All surfaces of metallic appurtenances in contact with potable water and not protected from corrosion by another system shall be shop-coated by the manufacturer. Appurtenances with damaged coatings shall be repaired or replaced as directed by the Engineer. Touch-up of damaged surfaces, when allowed by the Engineer, shall be performed in accordance with the manufacturer's recommendations.

2.06 BOLTS AND NUTS

- A. Bolts and nuts shall be as indicated below and shall be selected from the Approved Materials List.
- B. Cadmium-plated, zinc-plated or fluoropolymer coated bolts and nuts shall be used for the installation of pipelines up to 500mm (20") diameter and shall be carbon steel conforming to ASTM A307, Grade A, unless otherwise indicated on the approved drawings. Bolts shall be standard ANSI B1.1, Class A coarse threads. Nuts shall be standard ANSI B1.1, Class 2H coarse threads.
- C. Stainless steel bolts and nuts shall be used for the installation of pipelines 600mm (24") diameter and larger and for submerged flanges. Bolts and nuts shall be Type 316 stainless steel conforming to ASTM A193, Grade B8M for bolts, and Grade 8M for nuts. All bolt heads and nuts shall be hexagonal, except where special shapes are required. Bolts shall be of such length that not less than 6.4mm (¼") or more than 12.7mm (½") shall project past the nut in tightened position.

2.07 FLANGE GASKET

- A. Flange gaskets shall be full-face, 1/8 inch thick, cloth-inserted rubber sheet or Engineer's approved equal.

2.08 POLYETHYLENE ENCASEMENT

- A. Polyethylene encasement shall be as indicated below and shall be selected from the Approved Materials List. Polyethylene materials shall be kept out of direct sunlight exposure.
- B. Polyethylene sleeves shall be a minimum 0.305mm (0.012" or 12 mil) thick polyethylene plastic in accordance with AWWA C105.
- C. Polyethylene wrap shall be a minimum 0.203mm (0.008" or 8 mil) thick polyethylene plastic in accordance with AWWA C105.
- D. Polyethylene wrap and sleeves shall be clear for use with potable water and purple for use with recycled water.
- E. Polyethylene or vinyl adhesive tape a minimum of 50mm (2") wide or plastic tie straps shall be used to secure polyethylene encasement.

2.09 WARNING/IDENTIFICATION TAPE

- A. Warning/identification tape shall be as indicated below and in accordance with the Approved Materials List.
- B. Tape shall be an inert plastic film (non-metallic) formulated for prolonged underground use that will not degrade when exposed to alkalies, acids and other destructive substances commonly found in soil.
- C. Tape shall be puncture-resistant and shall have an elongation of two times its original length before parting.
- D. Tape shall be colored to identify the type of utility intended for identification. Printed message and tape color shall be as follows:

<u>Printed Message</u>	<u>Tape Color</u>
Caution: Waterline Buried Below	Blue
Caution: Recycled Waterline Buried Below	Purple
Caution: Sewerline Buried Below	Green
Caution: Cathodic Protection Cable Buried Below	Red
Caution: Electric Line Buried Below	Red

Ink used to print messages shall be permanently fixed to tape and shall be black in color with message printed continuously throughout.

- E. Tape shall be a minimum of 0.102mm (0.004" or 4mil) thick x 150mm (6") wide with a printed message on one side. Tape used with the installation of onsite potable and recycled water irrigation systems shall be a minimum of 100mm (4") wide.

2.010 TRACER WIRE

- A. Tracer wire shall be as indicated below and shall be selected from the Approved Materials List.
- B. Tracer wire shall be #14 AWG solid copper UF type wire with cross-linked polyethylene insulation. The insulation shall be white or yellow in color.
- C. Wire splices (at pipe tees, crosses and laterals) shall be accomplished using a direct bury silicone-filled capsule tube with standard wire nut or silicone-filled wire nut connectors of the appropriate size selected from the Approved Materials List.

2.011 VALVE STEM EXTENSIONS

- A. Stem extensions shall be complete with operating nut, location ring, and lower socket to fit valve-operating nuts. The configuration of the extension stem socket shall match that of the valve it operates.
- B. Stem extensions shall be square fiberglass tubing glued together to make a continuous one-piece unit used to a maximum length of 2.4m (8').
- C. Steel stem extensions shall be used where the maximum length of the extension exceeds 2.4m (8') or at the request of the Engineer. Steel stem extensions may be round or square hot-dipped galvanized steel tubing of solid design (no pinned couplings permitted) with guides.

2.012 RECYCLED WATER IDENTIFICATION

- A. Materials used to identify pipe and appurtenances used for recycled water and not manufactured in purple color.

PART 3 EXECUTION

3.01 TEMPORARY PIPELINES

- A. All temporary piping, fittings, and service connections shall be furnished, installed, and maintained by the Contractor, and the Contractor shall make connections to a water source designated by the Engineer.
- B. All pipe, valves, fittings, hose and connections furnished by the Contractor shall be of good quality, clean, and suitable for conveying potable water in the opinion of the Engineer.
- C. The temporary pipe shall be installed in such a manner that it will not present a hazard to traffic and will not interfere with access to homes and driveways along its route.
- D. Valves shall be installed at 60m (200') intervals or as directed by the Engineer. The use of pressure reducing valves (PRV) may be required as directed by the Engineer.
- E. The Contractor shall be responsible for disinfecting all pipe, connections, flushing, and assisting Utilities Inc. in taking water samples for bacteriological testing in accordance with Section 15041.

- F. Following disinfection and acceptance of the temporary pipe as a potable water system, the Contractor shall maintain continuous service through the temporary piping to all consumers normally served both directly and indirectly by the pipeline.
- G. Upon completion of the work, the Contractor shall remove the temporary piping and appurtenances.
- H. If progress in making repairs to the temporary pipeline is inadequate, the Engineer may order necessary corrective measures. Corrective measures may consist of directing Utilities Inc. personnel or another contractor to complete the work. All costs for corrective measures shall be borne by the Contractor.

3.02 FLEXIBLE MECHANICAL PIPE COUPLINGS

- A. Flexible mechanical-type couplings shall conform to ANSI/AWWA C606, "Standard for Grooved and Shouldered Type Joints."
- B. Flexible mechanical-type couplings of nominal size less than 12 inches shall be used with cut-grooved standard IPS pipe and shall be Romac Macro HP two-bolt Extended Range Couplers, Signma C153 MJxMJ Couplers, or Engineer's approved equal.
- C. Bolts, nuts and washers for couplings to be buried shall be cadmium plated, high-strength, low-alloy steel meeting the composition requirements of AWWA C111, stainless steel 304 or 316. All other installations shall have bolts and nuts meeting the requirements of AWWA C111. Type II Service Class 1, zinc-plated bolts, nuts and washers are also acceptable.

3.03 GROOVED-END OR SHOULDERED COUPLINGS FOR DUCTILE-IRON OR STEEL PIPE

- A. Grooved-end or shouldered couplings shall be installed in accordance with the manufacturer's recommendations and as described below:
- B. Grooved-end or shouldered joint couplings shall be installed per AWWA C606 and the manufacturer's recommendations.
- C. Clean loose scale, rust, oil, grease, and dirt from the pipe or fitting groove and touch-up the epoxy coating as necessary, allowing time for curing before installing the coupling.
- D. Clean the gasket before installation. Apply a lubricant selected from the Approved Materials List to the gasket exterior including lips, pipe ends, and housing interiors.
- E. Fasten the coupling alternately and evenly until the coupling halves are seated. Follow the manufacturer's recommendations for bolt torque using a properly calibrated torque wrench.

3.04 JOINT RESTRAINT SYSTEM

- A. Joint Restraint Systems shall be installed in accordance with the manufacturers recommendations and as described below:

- B. Length of pipe to be restrained on each side of bends, tees, reducers and other fittings shall be determined by the Private Engineer or manufacturer of the restraint device.
- C. Split ring restraint shall be installed on the spigot end of pipe, connected to a back-up ring which seats behind the bell of the adjoining pipe or fitting.
- D. Restraint devices can be installed prior to lowering pipe into the trench.
- E. Splined gaskets, also known as joint restraint gaskets, shall be installed in accordance with the manufacturer's recommendations.

3.05 BOLTS AND NUTS

- A. All bolts and nuts shall be new and unused.
- B. Bolts and nuts shall be cleaned, if needed, by wire brushing and shall be lubricated prior to assembly.
- C. Tighten nuts uniformly and progressively.
- D. Buried bolts and nuts shall receive a heavy coat of protective grease coating selected from the Approved Materials List prior to being wrapped with polyethylene.
- E. All stainless steel bolts shall be coated with an anti-seize compound selected from the Approved Materials List.
- F. Bolts and nuts shall not be reused once tightened. Used bolts and nuts shall be discarded and removed from the job.

3.06 POLYETHYLENE ENCASEMENT

- A. Polyethylene encasement shall completely encase and cover all metal surfaces.

Pipe: All ductile-iron pipe shall be encased with polyethylene sleeves in accordance with Method A described in AWWA C105, or with polyethylene wrap in accordance with Method C described in AWWA C105.

Fittings: Fittings such as tees, bends and reducers shall be encased with polyethylene wrap in accordance with AWWA C105.

Valves: Valves shall have only the stem and operating nut exposed and the wrap shall be attached so that valve operation will not disturb the wrapping or break the seal.

- B. Polyethylene sleeves shall be secured with polyethylene or vinyl adhesive tape or plastic tie straps at the ends and quarter points along the sleeve in a manner that will hold the sleeve securely in place during backfill. Polyethylene wrap shall be secured with polyethylene or vinyl adhesive tape in a manner that will hold the wrap securely in place during backfill.

3.07 WARNING/IDENTIFICATION TAPE

- A. Warning/Identification Tape shall be installed as described below in accordance with the Drawings.
- B. Tape shall be placed at the top of the pipe zone 300mm (12") above and centered over the utility intended for identification. Tape used with onsite potable and recycled water irrigation systems shall be installed at 150mm (6") above the pipe.
- C. Tape shall be installed with the printed side up and run continuously along the entire length of the utility intended for identification. Tape shall be installed on the main piping and all appurtenant laterals, including blowoffs, air valve assemblies, fire hydrants, and services. Tape splices shall overlap a minimum of 600mm (24") for continuous coverage.
- D. Tape shall be installed prior to placement of the Trench Zone Backfill.

3.08 TRACER WIRE

- A. Tracer wire shall be installed as described below in accordance with the Drawings.
- B. Tracer wire shall be installed with all water and recycled water mains.
- C. Wire shall be placed on the top centerline of the pipeline and shall run continuously along the entire length of pipe prior to placement of trench backfill. Wire shall be mechanically and electrically continuous throughout the pipeline, including within pipe casings.
- D. Tracer wire shall be secured to the pipe at 1.8m (6') intervals with plastic adhesive tape, duct tape or plastic tie straps. The wire may alternately be secured to the pipe by looping the tracer wire around itself such that tracer wire remains continuous atop the pipe during backfill operations.
- E. Tracer wire access ports shall be installed in accordance with the Drawings within the concrete splash pad of all fire hydrants installed as a part of the work. Tracer may terminate within meter boxes, blow off boxes, CP test boxes or air valve enclosures only as directed by the Engineer at intervals of not more than 305m (1,000'). Locations of all tracer wire access ports installed shall be noted on the as-built drawings.
- F. Wire shall extend into the access port and terminate with a coiled 600mm (24") length of wire. All tracer wire not located atop pipe shall be installed within a conduit at a minimum depth of 600mm (24") in accordance with the Drawings.
- G. Splices shall be installed only when necessary and shall be made using a wire connector selected from the Approved Materials List.
- H. The Contractor shall test tracer wire for electrical continuity in the presence of the Engineer prior to the installation of any paving over atop pipelines or appurtenances. Testing shall be accomplished using a Progressive Electronics 77M tone generator, or similar device, and a testing telephone handset.

3.09 VALVE STEM EXTENSIONS

- A. Valve Stem Extensions shall be installed when the valve-operating nut is more than 1.5m (5') below grade. Stem extensions shall be of sufficient length to bring the operating nut to a point

between 300mm (12") and 450mm (18") below the gate well lid. Valve stem extensions shall be installed in accordance with the Drawings.

3.010 INSTALLATION OF TEMPORARY END CAPS TO MAINTAIN SERVICE

- A. Before excavating for new mains that are to replace existing pipes or services, it may be necessary to install temporary end caps on existing pipes that are later to be abandoned or connected to in order to maintain service to customers or fire protection during construction. When indicated on the Approved Plans or when directed by the Engineer, Contractor shall install such temporary end caps as indicated below and in accordance with the Drawings.
- B. For existing water mains 350mm (14") or less in diameter, the existing pipe shall be cut cleanly and fitted with a rubber-gasketed ductile-iron solid end cap specifically designed for the size and type of pipe being temporarily capped. The end cap shall be adequately braced with a concrete thrust block poured against undisturbed material or as otherwise required to insure that no movement or leakage occurs.
- C. End caps shall be fitted with 50mm (2") tapped outlets if indicated on the Approved Drawings or if directed by the Engineer to provide a temporary 50mm (2") blowoff or a connection to a temporary water source.
- D. Existing pipes 400mm (16") or larger shall not be fitted with temporary end caps.
- E. Contractor shall maintain the temporary cap throughout the duration of the work and shall remove and dispose of all temporary materials used when the final connection has been made or when the temporary end cap is no longer required. Contractor shall install concrete plugs as described elsewhere within this section if the pipeline on which the end cap was installed is to be permanently abandoned.

3.011 PERMANENT ABANDONMENT OR REMOVAL FROM SERVICE OR EXISTING FACILITIES

- A. Permanent abandonment or removal from service of existing mains, appurtenances or water services shown on the Approved Plans or as called for by the Engineer shall be as indicated below and in accordance with the Drawings. All materials removed during construction operations shall be salvaged or disposed of in accordance with this Section. Permanent abandonment or removal from service of existing mains, appurtenances or water services shown on the Approved Plans shall be considered to include the complete removal of fittings such as tees, wyes, or tapping saddles that connect the pipeline(s) to be abandoned to source pipelines unless specifically shown otherwise on the Approved Plans. Segments of source pipelines so removed shall be replaced with straight pipe and appropriate couplings selected from the Approved Materials List or as directed by the Engineer.
- B. Abandonment in place:
 - 1. Existing pipe 100mm (4") and smaller shall have a short sections of pipe removed and pipe ends encased in concrete at intervals of 60m (200').
 - 2. Existing pipe 150mm (6") through 350mm (14") shall be cut and plugged with concrete or shall be pressure-grouted at intervals of 60m (200').

3. When existing pipe 350mm (14") or less is cut and plugged, or when a section is removed and the pipe ends are encased in concrete, a single excavation shall be performed to plug all exposed ends created by cutting the pipeline. The act of excavating and plugging all exposed ends is considered as a single "cut-and-plug."
4. Existing pipe 400mm (16") and larger shall be entirely filled by pressure-grouting or by blown sand.
5. Ends of all pipe segments to be abandoned shall be filled with concrete in accordance with the Drawings.
6. All valves shall be turned to the closed position.
7. Gate wells shall be cut 600mm (24") below grade and filled with concrete or removed and replaced with compacted backfill.
8. Water service corporation stops shall be closed. Meter boxes and curb stops shall be removed.
9. Water services to be abandoned that are connected to pipelines that will remain in service shall be abandoned in-place in accordance with the Drawings.
10. Sewer laterals shall be cut and plugged with concrete at the main as directed by the Engineer for the specific circumstance and material type identified.
11. Sewer manholes shall have the cover and frame, concrete ring, grade rings and cone section removed. Inlet and outlet piping shall be plugged with concrete, manhole void shall be filled with sand, and a 300mm (12") thick, reinforced concrete slab shall be poured over the top of remaining manhole. The Contractor shall backfill hole to ground surface with compacted select fill.

C. Removal by excavation:

1. Existing pipe and appurtenances shall be removed from the ground as indicated on the Approved Plans or as directed by the Engineer. All materials removed during construction operations shall be salvaged or disposed of in accordance with this Section.
2. Contractor shall provide measures that allow for the removal of existing sewer mains and appurtenances with no leakage of raw sewage. Transportation of sewer mains and appurtenances removed from service shall be in waterproof trucks to prevent raw sewage from leaking on public streets.
3. Removal of asbestos-cement pipe (ACP) and sewer mains and appurtenances shall be in accordance with all applicable State and Federal requirements.
4. Backfill, compaction, and surface repair of all excavations for removal of pipe and appurtenances shall be made in accordance with the Approved Plans, Section 02225 of the Standard Specifications, and the Drawings.

3.012 SALVAGE

- A. When the Contractor is required to remove existing pipe and appurtenances, or portions thereof, from the ground, such materials may, at the discretion of the Engineer, be considered salvage. All materials identified as salvage are considered property of Utilities Inc.
- B. The Contractor shall remove and temporarily stockpile all materials identified as salvage in a safe location that will not disrupt traffic or shall deliver salvage to the Utilities Inc.'s Field Operations Yard as directed by the Engineer.
- C. The Contractor shall legally dispose of all other materials in an appropriate manner. Disposal is the responsibility of the Contractor. Obtain concurrence from the agency having disposal jurisdiction with respect to disposal sites and transportation methods.

3.013 RECONNECTIONS

- A. The Contractor may encounter unused service laterals or appurtenant piping connected to an existing pipeline being replaced. Laterals and appurtenances piping that will not be connected to the new pipeline shall be abandoned as described above.
- B. Existing service laterals or appurtenances shall be connected to new pipelines as shown on the Approved Plans or as directed by the Engineer in accordance with the Drawings.

3.014 DISPOSAL

- F. All materials removed during construction operations and not identified by the Engineer, as salvage shall be legally disposed of in accordance with all applicable Local, State, and Federal requirements.
- B. Disposal of Asbestos-Cement Pipe requires special handling and attention, including but not limited to, encapsulation within airtight packaging, submittal of certification letters and/or waste profile statements, and the use of a NV-OSHA registered asbestos abatement contractor to transport and dispose of such wastes. Utilities Inc. shall be provided with copies of all applicable documentation regarding the transportation and disposal of Asbestos-Cement pipe. Contractor shall comply with all applicable regulations and all requirements of the disposal site. Contractor is responsible for all costs associated with disposal of materials, specifically including any materials that may contain asbestos.

END OF SECTION

SECTION 02625

PRESSURE PIPE, VALVES, AND FITTINGS

PART 1 GENERAL

1.01 SUMMARY

- A. Furnish all materials, equipment and services required for a complete installation of ductile iron pipe as specified and shown

1.02 REFERENCES

- A. ANSI/AWWA C151/A21.51 - Ductile-Iron Pipe, Centrifugally Cast in Metal Molds or Sand-Lined Molds for Water and Other Liquids.
- B. ANSI/AWWA C104/A21.4- Cement-Mortar Lining for Ductile-Iron Pipe and Fittings for Water.
- C. ANSI/AWWA C111/A21.11- Cement-Mortar Lining for Ductile-Iron and Gray-Iron Pressure Pipe and Fittings.
- D. ANSI/AWWA C115/A21.15 - Flanged Ductile-Iron and Gray-Iron Pipe with Threaded Flanges.
- E. ANSI/AWWA C110/A21.10- Ductile-Iron and Gray-Iron Fittings, 3 inch through 46 inch, for Water and Other Liquids.
- F. ANSI/AWWA C153/A21.53 - Ductile-Iron Compact Fittings, 3 inch through 12 inch, for Water and Other Liquids.
- G. ANSI/AWWA C600 - Installation of Ductile-Iron Water Mains and Their Appurtenances.
- H. AWWA C901 – Polyethylene (PE) Pressure Pipe and Tubing 1/2” (13 mm) Through 3” (76 mm)
- I. AWWA C906 – Polyethylene (PE) Pressure Pipe and Tubing 4” (100 mm) Through 65” (1,650 mm)
- J. ANSI/AWWA C111/A21.11 - Mechanical Joint Retainer Glands
- K. ANSI/AWWA C151/A21.57 - Mechanical Joint Pipe Centrifugally cast in metal molds.

1.03 RELATED WORK SPECIFIED ELSEWHERE

- A. SECTION 02675 PRESSURE AND LEAKAGE TESTING
- B. SECTION 02225 TRENCH EXCAVATION AND BACKFILL
- C. SECTION 02621 GENERAL PIPING SYSTEM AND APPURTENANCES

1.04 SUBMITTALS

- A. Shop Drawings: Submit Shop Drawings in accordance with the requirements in Section 01300.
- B. Submit hydrostatic test reports.

1.05 QUALITY ASSURANCE

- A. Certifications: Furnish certified affidavit of compliance for all pipe and other products or materials furnished under this Section.

PART 2 PRODUCTS

2.01 MATERIALS

- A. All materials shall be new and of current manufacture, and in accordance to the standards specified herein.

2.02 POLYVINYL CHLORIDE (PVC) WATER PIPE

- A. Water pipe shall AWWA C900, Class 150 PVC, for pipe 12 inch and under and AWWA C905 Class 150 PVC for pipe greater than 12 inches, unless other pressure class is indicated on the drawings.
- B. PVC pipe and fittings shall be manufactured from Type 1, Grade 1 “normal Impact PVC, Maximum Chemical Resistance Grade” as specified in ASTM D1784. Pipe dimensions shall be as specified in ASTM D1785. Fitting dimensions shall be as specified in ASTM D2466 and D2467.
- C. PVC JOINTS
 1. Joints for PVC pipe shall be the push-on type and the joints and gasket materials shall meet the requirements of AWWA C900.
 2. Where fittings are required, use ductile iron push-on or mechanical joint fittings. Restrained type fittings for PVC shall be ductile iron MJ with a split ring restraining clamp or special PVC restrained fittings or locking bell joints.

Acceptable restrained joint fittings are manufactured by EBAA Iron, Uni-Flange, and Smith-Blair, Inc.

2.03 HIGH DENSITY POLYETHYLENE PIPE

- A. High Density Polyethylene (HDPE) pipe shall conform to ASTM D 3350 designation PE-4710. The pipe shall have a minimum pressure rating of 100 pounds per square inch.
- B. The diameter and standard dimension ratio (DR) for the piping shall be as shown on the Drawings.

- C. The pipe shall be homogeneous throughout and free of visible cracks, holes, foreign inclusions or other injurious defects. It shall be uniform in color, opacity, density, and other physical properties.
- D. HDPE pipe shall have an ASTM D-3350 material Cell Classification of no less than 335434C.
- E. All pipe shall comply with ASTM F714.
- F. The polyethylene compound shall contain a minimum of 2 percent carbon black to withstand outdoor exposure without loss of properties. The polyethylene compound shall have a minimum resistance of 5,000 hours when tested for environmental stress crack in accordance with requirements of ASTM 1693.
- G. Pipes and fittings shall be homogenous throughout and free of visible cracks, holes (other than intentional manufactured perforations), foreign inclusions, or other deleterious effects, and shall be uniform in color, density, melt index, and other physical properties.
- H. Fittings at the ends of pipes shall consist of polyethylene unless indicated otherwise on the Drawings. Fittings supplied by manufacturers other than the supplier of the pipe shall not be permitted without the approval of the Engineer. HDPE fittings shall be in accordance with ASTM D3261.
- I. The pipe shall be marked at five foot intervals with a coded number which identifies the manufacturer, SDR size, PPI rating, manufacturing standard reference and production code from which data and place of manufacturer can be determined.
- J. When HDPE pipe is connected to ductile iron pipe, a flange adapter shall be used. A flange-coupling adapter shall be used on the ductile iron pipe. HDPE flange adapters shall be manufactured by the same manufacturer as the pipe using the same resin as the pipe. Each flange adapter shall be furnished with a ductile iron convoluted back-up ring drilled to match the standard ANSI bolt pattern for the nominal diameter of pipe used.
- K. Connection of the pipe and fittings shall be performed by the thermal butt fusion system. HDPE pipe lengths, fittings, and flange adapter connections to be fused shall be of the same type, grade and class of polyethylene compound and supplied by the same raw material supplier.
- L. Pipe and fittings bonded per this specification shall satisfy the requirements of ASME B31.3, latest edition, for pressure piping applications.

2.04 SCREWED STEEL PIPE AND FITTINGS

Steel pipe 2-1/2" and less in diameter shall be standard weight pipe conforming to ASTM A53 and shall be galvanized. Fittings for steel pipe shall be 150 lb. malleable iron conforming to ANSI B16.3 and shall be galvanized. Lines shall be fitted with sufficient unions to facilitate removal of all valves and appurtenances.

2.05 DUCTILE IRON PIPE

- A. Unless otherwise specified or shown on the drawings, ductile iron pipe shall be Class 52 and shall conform to ANSI/AWWA C151/A21.51.
- B. Ductile iron pipe shall be cement mortar lined in accordance with ANSI/AWWA C104/A21.4, except as modified herein.
 - 1. The thickness of the cement mortar lining shall not be less than 1/8 inch for 4 inch through 12 inch diameter pipe; and 3/16 inch for 14 inch through 24 inch diameter pipe.
 - 2. All ductile iron pipe shall be provided with an 8 mil polyethylene or other suitable permeable bulkhead on the ends of the pipe and all special openings.
- C. Ductile iron pipe installed below grade shall employ either mechanical joints or push-on joints conforming to ANSI/AWWA C111/A21.11 unless otherwise specified.
- D. Ductile iron pipe installed above grade shall employ flanged joints conforming to ANSI/AWWA C115/A21.15.
- E. Ductile-iron pipe and appurtenant components and materials shall be selected from the Approved Materials List in accordance with the Drawings.
- F. Ductile iron pipe having push-on, mechanical, or plain end connections shall be furnished within the following classes:

Pipe Diameter	Minimum Pressure Class	Minimum Thickness Class
Under 6-inch	350	52
6 to 16-inch	350	50
20 to 24-inch	300	50
30 to 36-inch	250	50
42 to 60-inch	200	50

- G. Minimum thickness class for pipe having threaded flanges or threaded shoulders shall be Class 53.
- H. Minimum thickness class for pipe having grooved end joints shall be as shown in the following table unless otherwise noted on the approved Drawings:

Pipe and Fitting Size (Diameter, in.)	Wall Thickness per AWWA C606
16 and smaller	Class 53
20	Class 54
24	Class 56

A. GASKETS

1. Mechanical joint rubber gasket configuration and materials shall comply with AWWA C111 and shall be in accordance with the applicable joint type and pressure rating of the piping system.
2. Flange gaskets shall be 3.2mm (1/8") thick acrylic or aramid fibers bound with nitrile for all sizes of pipe. Gaskets shall be full-face type with pre-punched holes.
3. Push-on joint rubber gaskets shall be per AWWA C111.
4. If organic solvents or petroleum products are encountered during the course of the work, alternate gasket materials or joint treatment may be required by the Engineer.

I. FITTINGS

Unless otherwise specified or shown on the Drawings, all fittings to be used with ductile iron pipe shall conform to the quality and wall thickness specified in ANSI/AWWA C110/A21.10 or as specified in AWWA C153/A21.53.

1. All gray-iron and ductile iron fittings shall be lined with cement mortar in accordance with ANSI/AWWA C104/A21.4.
2. All fittings and joint connections shall be thoroughly cleaned and coated or wrapped in accordance with AWWA C105.
3. All ductile iron mechanical joint fittings shall incorporate retainer glands, manufactured to a minimum ductile 60-40-12 grade for joint restraint. Set screws are to be manufactured from AISI 4140 steel case and core hardened un-plated. Set screws are to have knurled and cupped points. Drilling for set screws is to be AT a 10-degree angle. Screws for 3"-12" pipe are to have breakable automatic torque caps.

J. ACCESSORIES

1. Rubber gaskets for the sealing of joints on ductile iron pipe shall conform to ANSI/AWWA C111.A21.11.
2. Cement for mortar lining shall conform to the ANSI/AWWA C104.A21.4 and shall be Type II or Type V. A fly ash or pozzolan shall not be used as a cement replacement.
3. Water for cement mortar shall be potable water, clean and free from organic matter, strong alkalis, vegetable matter and other impurities.

K. SOURCE QUALITY CONTROL

1. Testing: All pipe shall be subject to a hydrostatic pressure test at the manufacturer's plant.
2. Inspection of Materials: All pipe and fittings shall be true, circular, and concentric with the barrel of the pipe cut off on a plane at right angles to the longitudinal axis of the pipe.

3. Interior: All pipe and fittings shall have smooth interiors and shall be free from injurious cracks, checks, blisters, broken extremities, and other imperfections.

2.06 VALVES

A. Gate Valves, 2 inch to 14 inch

1. Provide gate valves equal to Mueller 2360 Series conforming to AWWA C509, minimum 150 psig working pressure (unless indicated otherwise on the plans), resilient seated wedge, non-rising stem, O-ring packing, 2 inch square operator nut for buried service. Left hand opening, counter clockwise.
2. Factory applied minimum 6 mils dry film thickness, epoxy coating on all interior and exterior ferrous surfaces. Epoxy coating per AWWA C550. Valves 2 inch and smaller
3. Ball valve. Threaded bronze body chrome plate brass ball glass filled Teflon seats with standard port. Rated for 150 psi minimum working pressure. Valves mounted in air lines shall be suitable for 225° F.
4. Gate valve. Threaded all bronze, double disk, non-rising stem. Rated for 150 psi minimum working pressure.

B. Butterfly Valves:

1. General: Butterfly valves shall be of the tight closing, rubber seated type and fully comply with the latest revision of AWWA Standard C504, Class as required, and NSF61 where applicable. Valves shall be bubble-tight at rated pressure class in either direction, and shall be satisfactory for applications, involving throttling service and for applications requiring valve actuation after long periods of inactivity. Valve discs shall rotate 90° from the full open position to the tight shut position. Regardless of valve size, angular disposition of disc can be up to 1" off center without leakage.
2. Actuator: Provide hand lever actuator for valves 3 inch to 10 inch and hand wheel operator for valves 12 inch and larger. Provide 2 inch square operator nut and valve box for buried service.
3. Blower Air Discharge: Provide seat and seal materials suitable for a minimum of 225° F for valve application on the blower air discharge.
4. Quality: Provide valves equal to Mueller Lineseal III (Class 150B) butterfly valves.

C. Eccentric Plug Valves:

Provide DeZURIK, or equal, Eccentric Plug Valves conforming to AWWA C517, AWWA C111, ANSI B16.1 and/or ANSI B16.5 as appropriate for Eccentric Plug Valves.

Flanged valves shall conform to the 125 lb standard unless otherwise shown. Valves shall be operated by lever or gear operator unless otherwise shown. Equip valves less than 6 inch with a manual lever actuator. Valves 6 inch and larger shall be equipped with gear operators, lubricated and sealed to prevent entry of dirt and water into the operator. All shaft bearings

shall be furnished with permanently lubricated bearing surfaces. The operator shall clearly indicate valve position. Valves 4 inch and larger shall be epoxy coated in the water passages.

D. Rubber-Flapper Swing Check Valves: A shop drawing submittal is required.

1. Sewage Applications: APCO Series 100R Model 104P3
2. Water Applications: APCO Series 100SR Check Valves
3. Rubber-flapper swing check valves shall have a heavily constructed ductile-iron body and cover. The body shall be long pattern design (not wafer), with integrally cast-on end flanges.
4. Flapper shall be captured between the body and the body cover in a manner to permit the flapper to flex from closed to full open position during flow through the valve. Flapper shall be easily removed without need to remove valve from line. Check valves shall have full pipe size flow area. Seating surface shall be on a 45° angle requiring the flapper to travel only 35° from closed to full open position, for minimum head loss and non-slam closure.
5. The rubber flapper shall be high-strength coated fabric, coated both sides with 70 DURO, which creates an elastic spring effect, molded internally, to assist the flapper to close against a slight head to prevent slamming. When essential to create backflow through the check valve, provide an external backflow device, where specified.

2.07 SERVICE SADDLE CLAMP AND CORPORATION STOPS

- A. Service Saddle Clamp. Service saddle clamp shall be a brass, or epoxy coated steel saddle with stainless steel double strap as manufactured by Ford or an approved equal. Provide CC Type for services of one (1) inch or smaller to provide IPT Type for services larger than one (1) inch. Provide clamp gasket suitable for use with potable water. Provide minimum working pressure of 150 psig.
- B. Corporation Stops. Bronze alloy body with threaded and/or compression type connections suitable for service intended. Provide minimum working pressure of 150 psig.

2.08 VALVE BOX AND RISER

- A. Operating Nut Less than 5 Feet below Surface. Valve boxes shall be two (2) pieces or three (3) piece, depending on the manufacturer's recommendations. Valve boxes shall be the slide-type with a minimum 5-1/4 inch diameter shaft. Valve boxes including upper part, lower part, extensions and lids shall be cast iron. The valve box shall be specifically designed for the type of valve on which it is used. The valve box shall be of proper length for the depth of cover. The word "Water" or "Sewer," as appropriate shall be cast into the top of the lid.
- B. Operating Nut Greater than 5 Feet below Surface. Riser pipe shall be minimum 6 inch diameter PVC or DI pipe, frame and cover per ASTM A48 Class 30 painted or dipped with asphalt paint. Provide extension stem per detail. The word "Water" or "Sewer," as appropriate shall be cast into the top of the lid.

2.09 FLEXIBLE COUPLINGS

- A. Straight type flexible couplings for joining plain end PVC and ductile iron pipe shall be Rockwell No. 431, Dresser Style 153, or equal.
- B. Straight type flexible coupling for joining plain end steel pipe shall be Rockwell No. 411 or Dresser Style 38, or equal.
- C. Transition-type flexible coupling for joining plain end pipe of different outside diameter shall be Rockwell No. 433 or No. 415, or Dresser Style 162, or equal.
- D. Flexible pump connectors. Provide and install rubber expansion joints as shown on the plans. Expansion joints shall be of the arched type. Coupling shall be by means of flanges. Restrain pump discharge connections. Provide Metraflex style 100 single arch, Mercer, American Rubber or an approved equal.

2.010 FLANGED ADAPTERS

The flanged coupling adapters (FCA) shall combine a flexible coupling with a flange to create a compact, flexible fitting to connect plain end pipe to sewage valves using a 150 pound ANSI template.

All steel FCA's shall be coated with a protective coating consisting of fusion bonded epoxy in accordance with AWWA C213, or approved equal. Flanged coupling adapters shall be Rockwell No. 912 or 913, or Dresser Style 127 or 128, or an approved equal.

PART 3 EXECUTION

3.01 BURIED PIPE

Conform to Section 02225 Trench Excavation and Backfill and Section 02621 General Piping system and Appurtenances for all buried pipe.

3.02 HDPE PIPE INSTALLATION

- A. HDPE to HDPE connections shall be made by thermal butt fusion, in accordance with ASTM D2657. Fusion jointing shall utilize a pipe manufacturer approved fusion machine operated by experienced and qualified personnel. The CONTRACTOR shall provide three copies of a "Heat Fusion Qualification Guide," published by the HDPE manufacturer that provides criteria for inspection of thermal fusion joints. The guide shall include criteria for operator training requirements and experience; visual inspection criteria (including photographs) for both intact thermal fusion joints and sample strips cut for thermal fusion joints. The thermal fusion machine operator shall perform a minimum of three test joints in the presence of the ENGINEER. The test joints will be examined from both exterior appearances and from appearance of the joint cross section once the samples have been cut into strips.
- B. Bolted HDPE to HDPE connections shall include a polyethylene flange adapter (stub end) butt fused to the pipe, a backup flange ring, bolts, nuts and a gasket. Flange rings shall be Standard Steel ring Flanges, Class D, in accordance with AWWA C207. High strength bolts, nuts, washers and gaskets shall be in conformance with AWWA C207, Appendix A. Flange

rings, bolts, nuts and washers shall be hot dip galvanized after fabrication per ASTM A153 and A386. Gasket dimensions and bolt lengths shall be per pipe manufacturer's recommendations.

3.03 DUCTILE IRON PIPE INSTALLATION

- A. Install ductile iron pipe in accordance with ANSI/AWWA C600, and the manufacturer's recommendations except as otherwise specified or shown.
- B. All damaged or defective ductile iron pipe and appurtenances shall be rejected and removed from the job site.
- C. Trenches shall be in a reasonably dry condition when the pipe is laid.
 - 1. Employ dewatering methods as required to maintain the trench in a reasonably dry condition.
 - 2. Provide necessary facilities for lowering and properly placing the pipe sections in the trench without damage.
 - 3. The pipe shall be laid carefully to the lines and grades, or to the minimum depths shown, and the sections shall be closely jointed to form a smooth flow line.
- D. The following minimum covers shall be maintained unless otherwise shown:
 - 1. A minimum of 36 inches of cover shall be maintained over pipe 4 inches through 24 inches in diameter where there is not an established street grade.
- E. The maximum allowable joint deflection for push-on type joint and mechanical-joint pipe shall be as follows:

Push-on Type Joint

PIPE SIZE	DEFLECTION ANGLE	MAXIMUM OFFSET (INCHES)		RADIUS OF CURVE (FEET)	
		18FT LENGTH	20FT LENGTH	18FT LENGTH	20FT LENGTH
4" through 12"	2.5	9	10	415	460
14" through 24"	1.5	6	6	690	765

Mechanical-Joint Pipe

PIPE SIZE	DEFLECTION ANGLE	MAXIMUM OFFSET (INCHES)		RADIUS OF CURVE (FEET)	
		18FT LENGTH	20FT LENGTH	18FT LENGTH	20FT LENGTH
4"	4.0	15	17	260	290
6"	3.5	15	15	295	330
8" through 12"	2.5	9	10	415	460
14" through 24"	1.5	6	6	690	765

END OF SECTION

SECTION 02670

VALVES

PART 1 GENERAL

1.01 SUMMARY

- A. The Contractor shall furnish all valves in accordance with the drawings and specifications. All valves, including component parts thereof, shall equal or exceed the requirements set forth herein, and shall be manufactured by a firm normally engaged in the manufacture of such valves. All valves furnished for the work shall be new and shall be currently under manufacture.

PART 2 PRODUCTS

2.01 MANUFACTURER

- A. All valves shall be manufactured by a manufacturer approved by the Engineer.

2.02 TESTING/STANDARDS

- A. All valves shall be designed for a water working pressure of 150 psi, unless otherwise shown on the drawings or set forth in these specifications.
- B. The Contractor shall install and test all valves furnished in conformance with the drawings and specifications.
- C. The Contractor shall supply to the Engineer records of tests performed on valves or component parts thereof that are required by the AWWA Valve Standard specified in these specifications, if requested by the Engineer any time within a period of one year after the acceptance of the work.
- D. The Contractor shall provide to the Engineer, when requested by the Engineer, an Affidavit of Compliance with the specified AWWA Valve Standard or Section 1.4 of AWWAC550 for each lot or valve size furnished for the work.

2.03 SHOP DRAWINGS

- A. Shop drawings shall be furnished in accordance with Division 01300 of these specifications. Shop drawings shall be submitted with the valve operator in the position and orientation as shown on the drawings.

2.04 FLANGES

- A. Valves shall be furnished with flanged ends, hub ends, "Ring Tite" ends or any combination thereof as required by the drawings or these specifications.

- B. Valve flanges may be raised or plain faced with either a smooth or serrated finish and shall be faced and drilled to ANSI B 16.1, Class 250 cast iron flange dimensions, unless otherwise shown on the drawings or specified in these specifications.
- C. All interior bronze parts of valves, shall conform to the requirements of ASTM B 62, Specification for Composition Bronze or Ounce Metal Castings, unless otherwise required by these specifications or shown on the drawings.

2.05 OPERATOR

- A. All valve operators shall turn clockwise to close.

2.06 SEAT

- A. The Contractor shall lubricate the seat of all rubber-seated valves prior to installation with 111 Silicone Compound as manufactured by Dow Corning, G661 Silicone Compound as manufactured by General Electric, or an Engineer's approved equivalent.

2.07 PLUG VALVE

- A. Plug valves shall be Dezurik type PEC Eccentric Plug Valves with handwheel actuators or an approved equivalent. A submittal will be required.
- B. Valve ends shall be flanged ductile-iron in accordance with Section 02620 unless otherwise called for on the Approved Plans or directed by the District Engineer.

2.08 RUBBER-FLAPPER SWING CHECK VALVE

- A. Swing Check Valves: A shop drawing submittal is required.
 - 1. Sewage Applications: APCO Series 100R Model 104P3
 - 2. Water Applications: APCO Series 100SR Check Valves
- B. Rubber-flapper swing check valves shall have a heavily constructed ductile-iron body and cover. The body shall be long pattern design (not wafer), with integrally cast-on end flanges.
- C. Flapper shall be captured between the body and the body cover in a manner to permit the flapper to flex from closed to full open position during flow through the valve. Flapper shall be easily removed without need to remove valve from line. Check valves shall have full pipe size flow area. Seating surface shall be on a 45° angle requiring the flapper to travel only 35° from closed to full open position, for minimum head loss and non-slam closure.
- D. The rubber flapper shall be high-strength coated fabric, coated both sides with 70 DURO, which creates an elastic spring effect, molded internally, to assist the flapper to close against a slight head to prevent slamming. When essential to create backflow through the check valve, provide an external backflow device, where specified.
- E. Valve ends shall be flanged ductile-iron in accordance with Section 02620 unless otherwise called for on the Approved Plans or directed by the District Engineer.

- F. Check valves shall be tested by the manufacturer and the test results shall be approved by the District Engineer prior to shipment to the project. Check valves must unseat at a head no greater than 600mm (24") water column.

PART 3 EXECUTION

- A. Valves shall be installed at the locations indicated on the plans and per manufacturer's recommendations.

END OF SECTION

SECTION 03150

FORMWORK FOR CAST-IN-PLACE CONCRETE

PART 1 GENERAL

1.01 DESCRIPTION.

- A. Provide formwork for cast-in-place concrete as indicated, specified, and required.
- B. Work Included in This Section. Principal items are:
 - 1. Furnishing, erection, and removal of forms.
 - 2. Shoring and bracing of formwork.
 - 3. Setting of embedded items, and in non-waterbearing locations setting of pipe sleeves for mechanical and electrical work under direction of respective trade requiring holes for passage of pipe or conduit.
- C. Related Work Not Included in This Section.
 - 1. Furnishing embedded items with setting instruction. (Section 03300)
 - 2. Reinforcement. (Section 03200)
 - 3. Concrete mixing, placing and finishing. (Section 03300)
 - 4. Waterstops. (Section 03300)

1.02 QUALITY ASSURANCE.

- A. Three (3) copies of the Contractor's shoring and formwork drawings shall be filed with the Owner for record purposes only and not for review or approval. Forms, shoring and falsework shall be adequate for imposed live and dead loads, including equipment, height of concrete drop, concrete and foundation pressures, stresses, lateral stability, and other safety factors during construction.
- B. Standards and Tolerances. Formwork shall comply with ACI 347R-88, Recommended Practice for Concrete Formwork, except as exceeded by the requirements of regulatory agencies or as otherwise indicated or specified. Except as such other requirements mandate more rigid tolerances, formwork shall be designed and constructed to produce finished concrete conforming to tolerances given in ACI 117-90.

1.03 SUBMITTALS.

- A. Concrete construction joints and expansion joints shall be of the types and locations Indicated. Submit shop drawings showing sequence of forming and concrete placing operations, and location and type of required construction of any proposed expansion joints

not shown on the Drawings. Submit shop drawings at least fifteen (15) working days in advance of form fabrication.

PART 2 PRODUCT

2.01 FORM COATING

- A. Non-grain-raising and non-staining resin or polymer type that will not leave residual matter on surface of concrete or adversely affect bonding to concrete of paint, plaster, mortar, protective coatings, and waterproofing or other applied materials. Coatings containing mineral oils, paraffins, waxes, or other non-drying ingredients are not permitted. For concrete surfaces contacting potable stored water, the coatings and form-release agents shall be completely non-toxic.

2.02 LUMBER.

- A. WWPA No. 1 Structural Light Framing or No. 1 Structural Joists and Planks, or equal. Board forms, if used, shall be No. 2 Common or better, T&G or shiplap, S1S2E or better.

2.03 PLYWOOD.

- A. Plywood shall conform to U.S. Product Standard PS-1 and shall bear APA or DFPA grade mark.
- B. General Use. Exterior type, Grade B-B Plyform, Class I, minimum 5/8" thickness. Mill-oiling is not permitted.
- C. Special Use. Use one or more of the following materials, or equal:
 - 1. HDO coating two sides on Plyform, Class I, Exterior.
 - 2. Exterior Type Grade B-B Plyform, Class I, having 1/8" thick fully adhesive bonded facing on one side of tempered structural hardboard.
 - 3. Birch hardwood plywood, all plies of Arctic white birch, panel faces on both sides phenolic plastic impregnated and faced with phenolic plastic by the hot press process, panel edges factory sealed, bearing manufacturer's logo in lieu of grade mark.

2.04 METAL FORMS.

- A. True to detail, good condition, clean, free from dents, bends, rust and oil, and of adequate size as approved by the Engineer.

2.05 ROUND COLUMN FORMS.

- A. Structural quality fiberboard, metal tubes as specified for metal forms, or fibrous glass reinforced plastic.

2.06 METAL FORM TIES.

- A. Prefabricated rod, snap-off, or threaded internal disconnecting type of tensile strength to resist all imposed loads. Ties shall leave no metal within 12" of concrete surfaces after removal. Snap-off type ties shall have integral washer spreaders of diameter to fully close tie holes in forms. In waterbearing structures, ties shall be equipped with an integral waterstop, which shall remain in place.

2.07 FORM JOINT SEALERS.

- A. For joints between form panels, use resilient foam rubber strips, nonhardening plastic type caulking compound free of oil, or waterproof pressure-sensitive plastic tape of minimum 8-mil thickness and 2" width. For form tie holes, use rubber plugs, plastic caulking compound, or equal.

2.08 MOLDS.

- A. For grooves, drips, rebates, profiles, chamfers, and similar items, use smooth milled pine or douglas fir coated with specified form coating, or standard product extruded polymer plastic units of the indicated or required shapes.

PART 3 EXECUTION

3.01 FORM TYPES.

- A. Smooth Surface Concrete. Use specified plywood or metal forms, as approved, for interior and exterior exposed concrete and all formed concrete in contact with liquids, waterproofing and protective coatings. Metal forms shall be lined with plywood.
- B. General Concrete. Use either plywood or board forms for concealed surfaces, or form as specified for smooth surface concrete. Metal forms for general concrete need not be lined with plywood.
- C. Approval. Metal forms shall be furnished to the jobsite sufficiently in advance of construction for detailed inspection by the Engineer. Forms showing evidence of worn connections of tie-holes, damaged or warped surfaces, or any other unsatisfactory feature shall be ordered removed from the jobsite by the Contractor, and shall not be returned to the jobsite. Metal forms, faced forms, and other forms shall be maintained in good condition through the construction period, and when in the opinion of the Engineer this is no longer the case, the unsatisfactory material will be removed from the jobsite.
 - 1. Refer to Section 03300 for approval of form placement.

3.02 SHORING AND FALSEWORK.

- A. Distribute loads properly over base area on which shoring is erected, either concrete slabs or ground; if on ground, protect against undermining or settlement, particularly against wetting of soils.
- B. Alignment. Construct forms to produce in finished structure all lines, grades, and camber as required.
- C. Camber. Provide jacks, wedges, or similar means to induce camber and to take any settlement in formwork, which may occur either before or during placing of concrete.

Camber for beams and slabs shall be as and where indicated. Perform screening in such manner as to maintain beam depths and slab thicknesses.

3.03 FORM CONSTRUCTION.

- A. Build forms to exact shapes, sizes, lines, and dimensions as required to obtain accurate alignment, location and grades, and level and plumb work in finished structures. Provide for openings, offsets, keyways, recesses, moldings, reglets, chamfers, blocking, joint screeds, bulkheads, anchorages, and other required features. Make forms easily removable without hammering or prying against concrete. Use metal spreaders to provide accurate spreading of forms. Construct forms so that no sagging, leakage, or displacement occurs during and after pouring of concrete. Coat forms with specified coating material only prior to placement of reinforcing steel; do not allow coating to contact reinforcing bars. Provide 1-foot minimum clear opening over form for finishing concrete.
- B. Chamfers. Provide 3/4 inch x 3/4 inch chamfer strips for all exposed concrete corners and edges unless otherwise indicated.
- C. Recesses, Drips and Profiles. Provide types shown and required.
- D. Form Joints and Tie Holes. Seal joints between form panels with specified foam plastic strips, caulking compound, or tape. Unless form tie spreaders fully seal tie holes in forms, seal around ties with specified materials and prevent leakage of concrete mortar.
- E. Form Windows. Provide windows in forms wherever directed or necessary for access for concrete placement and vibration. Windows shall be of size adequate for tremies and vibrators, spaced at maximum 6 foot centers, horizontally. Windows shall be tightly closed and sealed before placing next lift of concrete.
- F. Cleanouts and Cleaning. Provide temporary openings in wall and column forms for cleaning and inspection. Prior to pouring, clean all forms and surfaces to receive concrete.
- G. Reglets and Rebates. Properly form all required reglets and rebates to receive flashing, frames, and other equipment. Dimensions, details, and precise positions of all such reglets and rebates shall be ascertained from the trades whose work is related to or contingent upon same, and the concrete work formed accordingly.
- H. Re-use. Clean and recondition form material before each re-use. Unsatisfactory material shall be rejected and removed from the site.

3.04 EMBEDDED PIPING AND ROUGH HARDWARE.

- A. All trades which require openings for the passage of pipes, conduits, and other inserts shall be consulted and the necessary pipe sleeves, anchors, or other required inserts shall be properly and accurately installed. Openings required by other trades shall be reinforced as indicated and required. Conduits or pipes shall be located so as not to reduce the strength of the construction, and in no case shall pipes other than conduits be placed in a slab 42" or less in thickness. Conduit embedded in a concrete slab shall not have an outside diameter greater than one-third of the thickness of the slab nor be placed below bottom reinforcing steel or over top reinforcing steel. Conduits may be embedded in walls provided they are not larger in outside diameter than one-third the thickness of the wall, are not spaced closer than three

diameters on center, and do not impair the strength of the structure. All conduit, piping and other wall penetrations or reinforcements shall be subject to Owner's policy and approval.

3.05 FIELD QUALITY CONTROL.

- A. Inspection of Forms. Refer to Article 3.01 C for approval requirements for forms prior to use, and to Article 3.05 B for requirements during concrete pours. Refer to Section 03300 "Cast-In-Place Concrete" for approval requirements for placement of forms.
- B. Control During Concrete Placement. Devices of the tell-tale type shall be installed on supported forms and elsewhere as required to detect formwork movements and deflection during concrete placement; plumb-bobs shall be utilized on forms for all walls and columns eight (8) feet or more in height. Required slab and beam cambers shall be checked and correctly maintained as concrete loads are applied on forms. Workmen shall be assigned to check forms during concrete placement and to promptly seal all mortar leaks.

3.06 REMOVAL OF FORMS AND SHORING.

- A. Do not remove forms or shoring until concrete has attained sufficient strength to support its own weight and all imposed construction and permanent loads. Any damage to the work resulting from early removal of forms or shoring or early imposed loading shall be corrected at no added expense to the District.
- B. Form Removal. Minimum times for removal after concrete placement are as follows:
 - Beam sides (but not shoring) 3 days
 - Column forms and wall forms 2 days
 - Forms for supported roof or floor
slabs (but not shoring)..... 14 days
 - Forms for slabs on grade..... 2 days
- C. Shoring and Falsework Removal. Do not remove shoring and falsework until twenty-one (21) days after concrete placement or until concrete has attained at least 90 percent of the twenty-eight (28) day design compressive strength as demonstrated by control test cylinders, whichever is earlier, but not sooner than fourteen (14) days.
- D. Restriction. Do not impose construction, equipment, or permanent loads on columns, supported slabs, or supported beams until concrete has attained the twenty-eight (28) day design compressive strength.
- E. Concrete Curing During Removals. Concrete shall be thoroughly wetted as soon as forms are first loosened and shall be kept wet during the removal operations and until curing media is applied. Potable water supply with hoses shall be ready at each removal location before removal operations are commenced. Contractor shall bear costs and delays caused by any damage resulting from early removal of forms or shoring. Refer to Section 03300, "Cast-In-Place Concrete" for curing requirements.

END OF SECTION

SECTION 03200

REINFORCING

PART 1 GENERAL

1.01 DESCRIPTION.

- A. Provide reinforcing work, complete as indicated, specified and required.
- B. Work Included in This Section. Principal items are:
 - 1. Furnishing and placing bar and mesh reinforcing for cast-in-place concrete including dowels for masonry work.
 - 2. Furnishing reinforcing steel bars for masonry, including delivery to the site.
- C. Related Work Not Included in This Section.
 - 1. Formwork (Section 03150).
 - 2. Cast-in-Place Concrete (Section 03300).

1.02 QUALITY ASSURANCE.

- A. Code Requirements. Unless otherwise specified, all work specified herein and as shown on the drawings shall conform to the applicable requirements of Chapter 26 of the Uniform Building Code, latest edition.
- B. Testing. Materials shall be tested as hereinafter specified and unless specified otherwise, all sampling and testing shall be performed by an Owner approved Testing Laboratory with cost borne by the Contractor.
 - 1. Test Samples. Bars, ties, and stirrups shall be selected by Testing Laboratory representative from material at the site or from place of distribution. Selection shall include at least two (2) pieces, each 18" long, of each sampling.
 - 2. Required Tests.
 - a. Identified Bars. Testing will not be required if reinforcement is taken from bundles as delivered from the mill, identified as to heat number and accompanied by certified mill analyses and certified mill test reports, and is properly tagged with Identification Certificate so as to be readily identified, unless otherwise directed by the Engineer.
 - b. Unidentified Bars. When positive identification cannot be made or when random samples are taken, tests shall be made from each five (5) tons or fraction thereof for each size. One tensile and one bend test shall be made from specimens of each size of reinforcement. Contractor shall bear costs and delays caused by testing unidentified bars.

- C. Standard. Reinforcing steel installations shall conform to the specification requirements of the Concrete Reinforcing Steel Institute "Manual of Standard Practice" (herein referred to as the CRSI Manual) except as otherwise indicated or specified.
- D. Field Quality Control. Continuous inspections, where required by the Special Conditions, shall be performed by the "Special Inspector" qualified and approved by Governing Building Code Authority or Inspector as otherwise qualified and approved by the Owner.
 - 1. Inspection of Reinforcing. Provide twenty-four (24) hour advance notice to permit inspection of in-place reinforcement prior to closing forms, and refer to applicable requirements of Section 03300, "Cast-In-Place Concrete".
 - 2. Concreting Operations. During concrete placing, assign construction personnel to inspect reinforcement and maintain bars in correct positions at each pour location.
 - 3. Welding Inspection. Where allowed, perform shop and field welding of reinforcing steel under continuous inspection of the Owner's Inspector or an Inspector representative of the Testing Laboratory approved by the Owner. Notify Owner at least twenty-four (24) hours in advance of any procedure involving the welding of reinforcement.

1.03 SUBMITTALS.

- A. Submit the following in advance of fabrication in conformance with applicable requirements of General Conditions.
- B. Shop Drawings. Submit six (6) sets of shop drawings for reinforcing steel prepared in accordance with ACI 315, "Manual of Standard Practice for Detailing Reinforced Concrete Structures". Show layouts, bending diagrams, assembly diagrams, dimensioned types and locations of all bar laps and splices, and shapes, dimensions, and details of bar reinforcing and accessories. Include layout plans for bar supports and chairs, with typical details. Owner's review shall be general, and acceptance will not relieve Contractor of responsibility for accuracy.
- C. Samples. Submit two (2) 12" long samples of each bar support and two (2) samples of each individual type chair, with catalog data.

PART 2 PRODUCTS

2.01 REINFORCING.

- A. Use deformed bars conforming to ASTM A615, Grade 60 Type "S". Where welding of reinforcing is required, use deformed bars conforming to ASTM A706 unless otherwise specifically designated on Drawings.

2.02 WELDED WIRE MESH.

- A. Conform to ASTM A185.

- 2.03 TIE WIRE.
- A. Annealed steel, 16 gage minimum.
- 2.04 COUPLER SPLICE DEVICES.
- A. Reinforcing bar coupler/splice devices which bear current I.C.B.O. Research Recommendation Approval, and which develop at least 125 percent of bar yield strength in tension may be used in lieu of lapped bar type splices. Submit for Owner's approval in each instance.
- 2.05 SUPPORTS AND ACCESSORIES.
- A. Use no aluminum, galvanized steel, plastic or stainless steel supports or accessories. Supports shall conform to CRSI Manual of Standard Practice, Chapter 3, for Types SB, BB, BC, JC, HC, CHC, and others of standard types as required, or precast concrete block supports (DOBIES) with embedded wire ties or dowels. Metal chairs shall be Class "1" plastic coated chairs and spacers.
- 2.06 DOWELS.
- A. Where and as designated on Structural Drawings, provide reinforcing bar dowels in new work and for anchorage to existing concrete.
- 2.07 FABRICATION AND DELIVERY.
- A. Conform to CRSI Manual Chapters 6 and 7 except as otherwise indicated or specified. Bundle reinforcement and tag with suitable identification to facilitate sorting and placing, and transport and store at site so as not to damage material. Keep a sufficient supply of tested, approved, and proper reinforcement at site to avoid delays.
- B. Bending and Forming. Fabricate bars of indicated size and accurately form to shapes and lengths indicated and required by methods not injurious to materials. Do not heat reinforcement for bending. Bars with kinks or bends not scheduled will be rejected. Field bend NO bars that are partially embedded in concrete, except as shown on the plans or specifically approved by the Engineer.
- C. Reinforcing Bars for Masonry. Bars shall be detailed and fabricated at the shop, ready for installation by masons.

PART 3 EXECUTION

- 3.01 PLACING.
- A. Unless otherwise indicated or specified, conform to CRSI Manual Chapter 8 including placement tolerances, except no reduction of concrete cover is allowable for bars at concrete surfaces exposed in liquid or water-containing structures.
- B. Cleaning. Before placing reinforcing, and again before concrete is placed, clean reinforcement of loose mill scale, oil, or other coating that might destroy or reduce bond. Do

- not allow form coatings, release agents, bond breaker, or curing compound to contact reinforcement.
- C. Concrete Coverage. Concrete coverage over reinforcing bars shall be as indicated on the Drawings. The coverage shall be to the outer edge of ties, stirrups, bar spacers, hangers, and like items, and the reinforcing shall be detailed and fabricated accordingly. Refer to Structural General Note requirements of the Drawings.
- D. Securing in Place. Accurately place reinforcement and securely wire tie in precise position at all points where bars cross. Tie stirrups to bars at both top and bottom. Bend ends of binding wires inward allowing no encroachment on the concrete cover; exercise special care at surfaces to remain exposed and unpainted. Support bars in accordance with CRSI Manual Chapter 3, Specifications for Placing Bar Supports, using approved chairs and supports. Ties or supports for reinforcing bars and mesh properly placed and tied into position are not to be removed or dislodged for the convenience of other crafts or for the purpose of crawl holes.
- E. Splices. Splices shall be wired contact lap splices unless otherwise indicated or approved. Splices shall conform to ACI 318, (Class A) (Class C) top bars and Typical Structural Details, except where lap length is indicated on the Drawings.
1. Vertical Bars. Splicing of vertical bars in concrete is not permitted except at the indicated or approved horizontal construction joints or as otherwise specifically detailed.
 2. Horizontal Bars. Unless otherwise shown, make lap splices with at least one continuous bar between adjacent splices. Splices in any one run of bar shall be spaced at least twenty (20) feet apart with splices in adjacent bars offset at least ten (10) feet. Where double mats of bars occur in walls, lap splices in opposite mats shall be offset at least five (5) feet.
- F. Welding. Welding of reinforcing bars is not permitted unless indicated or approved in each case, with continuous inspection as hereinbefore required. Welds for securing crossing bars are not allowed. Perform welding in shop or field by direct electric arc process, with thoroughly trained and experienced certified operators qualified in accordance with AWS Code. Conform all welding to AWS "Structural Welding Code - Reinforcing Steel". Use low-hydrogen electrodes. Welds shall develop at least 125 percent of the yield strength of the connected bars.
1. Preparation. Clean surfaces to be welded of loose scale and all foreign material. Clean welds each time electrode is changed. Chip burned edges clean before welds are deposited.
 2. Characteristics of Welds. When brushed with wire brushes, completed welds shall exhibit uniform section, smoothness of welded metal, feather edges without undercuts or overlays, freedom from porosity and clinkers, and good fusion with penetration into base metal. Cut out welds or parts of welds found defective with chisel and replace with proper workmanship; cutting torch for removing defective welding is not acceptable.
- G. Additional Reinforcing. Provide additional reinforcing bars at sleeves and openings as indicated or required. Where additional bars are not shown for such locations, obtain Engineer's instructions and provide additional bars as directed, at no extra cost to the Owner.

- H. Welded Wire Mesh. Install necessary supports and chairs to hold in place during concrete pours. Straighten mesh to lay in flat plane and bend mesh as shown or required to fit work. Laps shall be no less than one complete mesh unless otherwise detailed. Tie every other wire at laps.
- I. Dowels. For anchorage where shown or required to existing construction, use non-shrink epoxy type grout or deferred bolting devices as approved in each instance and conforming to "Product" Article requirements of Section 03300, "Cast-In-Place Concrete".
- J. Holes for epoxying dowels in place in existing concrete shall provide 2" minimum clearance on all sides of dowel bar.

END OF SECTION

SECTION 03300

CAST-IN-PLACE CONCRETE

PART 1 GENERAL

1.01 DESCRIPTION.

- A. Provide cast-in-place concrete work, complete as indicated, specified and required, including all appurtenant work as indicated.
- B. Work Included in This Section. Principal items are:
 - 1. All cast-in-place concrete including bases for mechanical and electrical equipment.
 - 2. Concrete standards, materials, mixes and tests, placement, finishing, patching, grouting, and crack repair.
 - 3. Embedded waterstops for cast-in-place concrete.
 - 4. Concrete curing.
 - 5. Sealing of joints in liquid-containing structures and elsewhere shown.
 - 6. Treatment of concrete surfaces.
- C. Related Work Not Included in This Section.
 - 1. Formwork (Section 03150).
 - 2. Reinforcing work (Section 03200).
 - 3. Concrete Unit Masonry (Section 04220).
 - 4. Architectural finishing
 - 5. Sealers, coatings, and waterproofing for treating concrete surfaces.
 - 6. Pre-stressed concrete.
- D. Definitions.
 - 1. Water-Bearing Structure shall be construed to mean any structure any part of which contains water or process liquids, or which protects spaces from groundwater.
 - 2. Definitions of surface treatments of concrete structures.
- E. Waterproofing. The Division 7 material to be applied, or the application of Division 7 material, to either earth-supporting below-grade surfaces or water-bearing surfaces of either

existing or new walls common to occupied areas (i.e. galleries, pump rooms, etc.), for the purpose of making such walls impervious to water or sewage.

- F. Damp-proofing. The Division 7 material to be applied, or the application of Division 7 material to either earth-supporting below-grade surfaces or water-bearing surfaces of either existing or new walls common to occupied areas (i.e. galleries, pump rooms, etc.), for the purpose of retarding the passage or absorption of water or water vapor. An alternate specified method of damp-proofing might be the addition of a suitable admixture or treated cement to the concrete.
- G. Coating. The Division 9 material or system, or application of Division 9 material or system, to protect or paint concrete surfaces.
- H. Sealer. A coating applied to seal the pores in an uncoated surface.
- I. The sealer for surfaces to be painted is the prime or first coat of a Division 9 painting system.
- J. The sealer for surfaces to be left unpainted is a clear transparent waterproof coating.
- K. Seal Coat. A layer of Division 2 bituminous material applied to seal the concrete surface.
- L. Sealant or Sealing Compound. A Division 7 impervious material for the purpose of excluding water by sealing or caulking joints in water-bearing surfaces or traffic surfaces, for the purpose of excluding moisture or sound by sealing or caulking joints in surfaces or partitions, or for the purpose of providing a bond breaker.

1.02 REFERENCE STANDARDS.

- A. Except herein modified, concrete work shall conform to the latest requirements/edition of ACI 301, Specifications for Structural Concrete for Buildings, and to requirements of ACI Standards and ACI Recommended Practices as contained therein.

1.03 SOURCE QUALITY CONTROL.

- A. Code Requirements. Unless more stringent requirements are specified herein and/or shown on the Drawings, all work shall conform to the applicable requirements of the Uniform Building Code, latest edition.
- B. Testing. Materials shall be tested as hereinafter specified and unless specified otherwise all sampling and testing shall be performed by Owner approved Testing Laboratory with cost borne by the Contractor.
 - 1. Portland Cement. Submit notarized Mill Certificates, provided by the cement manufacturer, including full compliance with requirements specified. In the absence of certificates, Testing Laboratory shall perform tests for each 250 barrels of cement at Contractor's expense, tests made in accordance with ASTM C150 with tensile strength test made at 7 days. Cement shall be tagged for identification at location of sampling.
 - 2. Stone Aggregate for Concrete. Test aggregate before and after concrete mix is established and whenever character or source of material is changed. Include a sieve analysis to determine conformity with limits of gradation. In accordance with ASTM C75, take

samples of aggregates at source of supply or at the ready-mix concrete plant. Submit certified test results.

- a. Sieve Analysis. ASTM C136.
 - b. Organic Impurities. ASTM C40. Fine aggregate shall develop a color not darker than reference standard color.
 - c. Soundness. ASTM C88. Loss resulting therefrom, after 5 cycles, shall not exceed 8% of coarse aggregate, 10% for fine aggregate.
 - d. Abrasion of Concrete Aggregate. ASTM C131; loss shall not exceed 10½% after 100 revolutions, 42% after 500 revolutions.
 - e. Deleterious Materials. ASTM C33.
 - f. Materials Finer Than 200 Sieve. ASTM C117; not to exceed 1% for gravel, 1.5% for crushed aggregate per ASTM C33.
 - g. Reactivity Potential. ASTM C289. Ratio of silica released to reduction in alkalinity shall not exceed 1.0.
- C. Applicator. The applicator of waterproofing, damp-proofing, coatings, sealers, seal coats, or sealants shall be approved by the manufacturer of the material.

1.04 CONCRETE MIX DESIGNS AND PRELIMINARY TESTS.

- A. At Contractor's expense, Testing Laboratory shall prepare mix designs for all cast-in-place concrete to have the required 28-day compressive strengths, and shall perform preliminary testing in accordance with the following requirements. Test results shall be submitted to the Owner. **Contractor may furnish mixes as specified in Part 2.02 in lieu of trial batches where appropriate.**
- B. Mix Designs.
1. Strength Requirements. Design concrete mixes for use in various locations, for minimum 28-day compressive strengths and maximum aggregate sizes required by Structural Drawings and these Specifications, as follows, except as otherwise specified in the Special Conditions:
 - a. 4,000 psi Concrete. 4000 psi concrete shall be provided throughout except as specified hereinafter, or in the Special Conditions.
 - b. 3,000 psi Concrete. 3,000 psi concrete shall be provided for concrete used in:
 1. all reinforced concrete, interior and exterior, not otherwise specified;
 2. anchors and anchor walls;
 3. pipe cradles, encasements, and beam supports;
 4. reinforced valve supports;
 5. concrete for grout topping (with reduced-sized aggregate as directed);
 6. paving;

7. sewer manhole bases and collars;
 8. sewer tree lateral clean-out supports;
 9. sewer chimney lateral supports.
 10. Non-machine laid curbs and gutters
 11. Spandrels
 12. Driveways and approaches
 13. Sidewalks
 14. Exterior slabs
 15. Stairs on grade
- c. 2,500 psi Concrete. 2,500 psi concrete shall be provided for non-reinforced concrete used in:
1. sewer overflow encasements;
 2. sewer lateral joint encasements;
 3. pipe joint mortar;
 4. fence post footings;
 5. non-reinforced cut-off walls;
- d. 2,000 psi Concrete. 2,000 psi concrete shall be provided for concrete used in:
1. non-reinforced thrust blocks and pipe pads;
 2. valve supports;
 3. sewer clean-out supports not otherwise specified.
2. Basis for Mix Designs. Design concrete mixes for workability of mix and durability of concrete. Concrete mixes shall be rigidly controlled in accordance with laboratory trial batch method or combinations of materials previously evaluated as required by Sections 5.3, respectively, Standard Building Code Requirements for Reinforced Concrete (ACI 318, latest edition), of the American Concrete Institute and to satisfy herein specified concrete strength requirements. When, in the opinion of the Engineer, it becomes necessary to increase the cement content to gain the required strength, such adjustment shall be made at the Contractor's expense.
3. Water/Cement Ratios. Mixes for normal weight aggregate concrete shall be designed within the following maximum water/cement ratios when concrete is to be used in the various locations:
- a. For 4,000 psi water-bearing structural concrete limit water/cement ratios by weight as follows:
 1. Freshwater-bearing structures 0.48 maximum
 2. Sewage-bearing structures 0.45 maximum

- b. For all other concrete, water/cement ratios shall be no greater than 0.53.
- C. Preliminary Strength Tests. In laboratory, prepare nine (9) compression test cylinders for each concrete mix design (unless more tests are required for an earlier age). Fabricate and cure cylinders in accordance with ASTM C31. Use concrete, aggregates and admixtures proposed for the concrete work. In accordance with ASTM C39, test three sets of two cylinders at 28-day age. For each mix, no individual strength test result shall fall below the required f_c' .
- D. Drying Shrinkage Tests. For each mix design used for preliminary strength tests, using same concrete materials including admixtures, prepare three (3) test specimens for drying shrinkage testing. Specimens shall be 4 inch by 4 inch by 11 inch prisms fabricated, cured, and tested in accordance with ASTM C157, using 10 inch effective gauge length. Measurements shall be taken at one (1) day, seven (7) days, fourteen (14) days and twenty-one (21) days of curing. Zero measurement shall be the one day reading when determining shrinkage. The measurements after 7, 14, and 21 days of drying shall be taken and reported separately. The average drying shrinkage of each set of test specimens after two (2) days of drying shall not exceed 0.036% for concrete in all portions of water-bearing structures and not exceed 0.05% for all other structural concrete, except concrete for footings, piles and pile caps will not require drying shrinkage tests. Single specimens shall be within a tolerance of 25% of said maximum percentage.
- E. Reports. File three (3) copies of each mix design, preliminary strength test report, and drying shrinkage test report with Owner for review and approval. Contractor shall submit a letter of certification by an approved testing laboratory that the concrete materials, mixes, properties, and work conform to the requirements indicated and specified.

1.05 PRODUCT DELIVERY, STORAGE, AND HANDLING.

- A. Deliver materials in a timely manner to insure uninterrupted progress of work. Store materials in a manner that will preclude damage and permit ready access for inspection and identification.
- B. Materials for treatment of concrete surfaces. The contractor shall deliver sealers, coatings, waterproofing, or other surface treatment materials to the site in their original, unopened containers with the manufacturer's labels intact, describing contents and manufacturer.
- C. Stored materials shall be kept covered and precautions shall be taken for the prevention of fire. Empty containers and soiled or oily rags shall be removed from the site at the end of each day's work.

1.06 PAYMENT.

- A. Payment for cast-in-place concrete shall be based upon concrete poured and found acceptable upon the removal of forms and performance of required finishing. Under no conditions will more than 90% payment be made for concrete formed and poured until required finishing is completed.
- B. On large structures requiring construction over multiple payment periods, consideration may be given by the Engineer for payment as follows:

- C. Forms and rebar in place and accepted for concrete pour - 50% maximum of concrete price per cubic yard.
- D. Concrete poured and forms stripped, and found acceptable to the stage of construction - 35% maximum of concrete price per cubic yard.
- E. Concrete finished and found acceptable - 15% of concrete price per cubic yard.

PART 2 PRODUCT

2.01 MATERIALS.

- A. Portland Cement. Standard brand of domestic Portland cement, ASTM C150, Type II, low alkali. Do not change brand of cement during progress of work without written approval of Engineer. For concrete exposed to sulfate-containing soils, solutions or other chemically aggressive solutions, use Type V Portland cement as specified.
- B. Normal Weight (Stone) Aggregates. Furnish natural aggregates from approved pits, free from opaline, chert, feldspar, mica (fools gold), siliceous magnesium limestone or other deleterious or reactive substances. Conform to ASTM C33 except as modified herein. Fine aggregates shall pass a #4 sieve. Do not use pozzolan or other additives to compensate for aggregate alkali reactivity.
 - 1. Coarse Aggregates. Clean, hard, fine-grained sound crushed rock or washed gravel which does not contain in excess of 5% in weight of flat, chip-like, thin, elongated, friable or laminated pieces, or more than 2% by weight of total amount of cherty material and soft particles, or more than 1% of chert as soft material as defined on Table 3 of ASTM C33. Consider any piece having a major dimension in excess of 5 times its average dimension to be flat or elongated.
 - 2. Maximum Sizes. As indicated on Drawings, except for concrete in water-bearing structures where coarse aggregate sizes per Table 2 of ASTM C33 shall be No. 467 (12 inches), No. 57 (1 inch), or No. 67 (3/4 inch) as otherwise required by design, specifications and ASTM C33, and except that coarse aggregate nominal maximum size shall not exceed one-fifth the narrowest dimension between sides of form, one-third the depth of slabs, or three-fourths of minimum clear spacing between reinforcing bars.
 - 3. Quality. All aggregates shall meet the test requirements of Article "Source Quality Control" hereinbefore.
 - 4. Abrasive Aggregate. "Alundum" by Norton Company, "Carborundum" by Union Carbide, or equal aluminum oxide, uniformly graded between No. 12 and No. 30 sieves, applied uniformly at minimum rate of 1/4 lb. per sq. ft. and locked into cement matrix with the final troweling.
- C. Admixtures. **Use one manufacturer's products throughout.** Upon Engineer's approval of use and of a particular brand or type, assure that use is reflected in mix designs. Approved manufactures are W.R. Grace and Master Builder Products.
 - 1. General. Use no admixture containing chlorides or triethanolamine. Admixtures used in combination shall be physically and chemically compatible and shall be so certified by each admix manufacturer and by Testing Laboratory that prepared respective mix

designs.

2. Retarding-Densifier Admixture. In all concrete use a hydroxylated carboxylic acid type admixture in the amounts recommended by the manufacturer. The admixture shall provide the following, and Contractor shall provide proof thereof at time of request for approval:
 - a. Decrease drying shrinkage.
 - b. Increase compressive strength at all ages up to and including five (5) years.
 - c. Increase flexural strength, modulus of elasticity, and abrasive resistance.
 - d. The water/cement ratio and required strengths shall be maintained as scheduled (cement factor for a cubic yard of concrete, reduced proportionately).
 - e. There shall be no loss of workability resulting from reduction in slump. If the admixture is of liquid type, it must be considered in proportioning water.
3. Air Entrainment. Use air entrainment additive conforming to ASTM C260 as approved by the Owner.
 - a. For normal weight aggregate concrete subject, after curing, to freezing temperature while wet shall contain air entrainment within limits of Table 4.2.1 of ACI 318, latest edition and Table 4.2.2.4 of ACI 301, latest edition.
 - b. Air Entrainment in Water-bearing Concrete Structures, as determined in accordance with ASTM C231 or C173, shall provide air contents as follows for mixes with the following coarse aggregate sizes:
 - 5% ± 1% for Size 467 (12 inch nominal size)
 - 6% ± 1% for Sizes 57 or 67 (1 inch or 3/4 inch nominal sizes)
- D. Water. Water shall be provided from a domestic potable source.
- E. Expansion Joint Material. Type I, preformed sponge neoprene expansion joint filler conforming to AASHTO Designation M-153.
- F. Bituminous Mastic. For fills at specific designated locations (such as fills at precast panel lift-eyes and dowel hole fills in precast concrete panels) use either Hot-Applied Type Joint Sealer, ASTM D1190 or Cold-Applied Type Joint Sealant, ASTM D1850. Material shall bond to concrete, prevent moisture infiltration and, when set, shall be non-tracking at summer temperatures.
- G. Waterstops. Waterstops shall be produced by an extrusion process in such a manner that any cross section shall be dense, homogeneous and free from porosity and other imperfections. They shall be symmetrical in cross-sectional shape and uniform along their length.

The manufacturer must certify in writing that all waterstops are extruded from elastomeric polyvinyl chloride compound and that this compound shall be virgin PVC compound and not contain any scrap or reprocessed materials whatsoever.

The manufacturer must also certify in writing that all waterstops meet or exceed the physical properties requirements set forth in the U.S. Corps of Engineers' CRD-C572-74 specification and furnish a copy of certified independent laboratory test data showing compliance.

All waterstop intersections (ells, tees, crosses, etc.) shall be fabricated by the manufacturer and these shall have 2 ft. long legs to facilitate field butt splicing. Where field dimensions are encountered which will not accommodate the specified waterstop, waterstop of reduced dimension may be approved by the Engineer for a specific application.

- H. Concrete Joint Sealants. For sealing joints in nonwater-bearing concrete surfaces, use materials conforming with requirements specified in Section 07920, "Sealants and Caulking". For sealing concrete joints which will be immersed or intermittently immersed in water or sewage-bearing surfaces, use: Karlee Company's "Lastex M" 100 percent solids polyurethane sealant; Mameco International's Vulkem 227, Vulkem 45, or Vulkem 245 contingent upon need for self-leveling, non-sag and atmospheric humidity at time of usage; Hunt's Seal Flex 227-U Special Reservoir Grade polyurethane sealant; or equal.
1. Primer. Use primer produced and/or recommended by sealant manufacturer.
 2. Back-up Preformed Joint Filler. Use closed-cell polyethylene foam or equal impervious, compatible, compressible foam material recommended for retaining sealant depth in expansion joints while curing. Use no bitumen or oil saturated material.
 3. Bond Breakers. Bond breakers, where required, shall be polyethylene tape or equal as recommended by sealant manufacturer to prevent adherence of sealant to back-up material.
- I. Dry Pack Mortar. Dry pack mortar shall consist of by volume one part special cement, three parts sand and water. The special cement and sand shall be combined in the proper proportions and then thoroughly mixed with the required amount of water. The dry pack mortar shall contain only enough water to permit placing and packing and shall be mixed for the time limit as indicated by the manufacturer in advance of use. The dry pack mortar shall be placed against thoroughly wet concrete and shall be cured by water, fog spray, spray-on membranes, sisal kraft paper, or other curing method acceptable to the Owner.
- J. Grout. Grout to be applied to the concrete surface shall consist of one part Portland Cement to three parts dry, washed sand to sufficient water to allow placement, screening, and finishing.
- K. Rich Grout. Rich grout shall consist of by volume one part Portland Cement, two parts sand and water. The rich grout shall be mixed and cured in the same manner as required for dry pack mortar.
- L. Neat Grout. Neat grout shall consist of Portland Cement, flyash, water and optional admixtures. Neat grout is intended to be injected under low pressure to backfill the annular space between steel casing pipes and carrier pipes.
- M. Nonshrink Grout. Nonshrink grout shall be made with the following proportions:
- One part Type II Portland Cement (one sack);
 - One part Nonshrink Aggregate (100 lbs.);
 - One part clean, well graded concrete sand (100 lbs.);
 - Approximately 5.5 gallons of water per sack of cement
1. In all locations where the surface of the grout will be exposed to view, the nonshrink grout shall be recessed approximately one-half inch back of the exposed surface and the recessed area filled with cement mortar grout.

- N. Nonshrink Concrete. All nonshrink concrete shall contain one pound of nonshrink aggregate per pound of water that is in excess of two gallons per sack of cement. Recess surface exposed to field as specified for nonshrink grout above.
- O. Nonshrink Aggregate. Nonshrink aggregate shall be non-metallic as produced by Master Builders, an equivalent product of Sonneborn, or a product by any other manufacturer that will meet the same ASTM requirements and equal performance.
- P. Epoxy. Epoxies for grouting, crack repair, patching, bonding or other uses shall be as follows as manufactured by Adhesive Engineering Company, Sika Chemical Company, or equal by other manufacturer. Throughout, use products of single manufacturer.
1. All epoxy mixing, surface preparation and application shall be made in conformance with manufacturer's printed specifications, as approved by the Engineer.
 2. For bonding new concrete to old concrete and for grouting metal anchors, use Sika's "Sikadur Hi-Mod", Adhesive Engineering Company's Concessive 1001-LPL, except Concessive 1170 or 1422 shall be used as recommended by manufacturer to satisfy entailed project temperature and surface moisture variations at time of application; or equal.
 3. For patching concrete surfaces, making high strength epoxy concrete or grout, and grouting metal anchors, use Sika's "Sikadur Hi-Mod LV"; Adhesive Engineering Company's "Concessive 1180"; or equal.
 4. For pressure injection or gravity-feed grouting, use Sika's "Hi-Mod LV"; Adhesive Engineering Company's "Concessive Structural Concrete Bonding Process System" as recommended by manufacturer and approved by Engineer; or equal.
- Q. Floor Hardener. Use hardened, non-metallic aggregate dust-on type floor hardener consisting of a single manufacturer's system equal to L. M. Scofield Company's natural gray "Lithochrome Hardener" applied uniformly at rate of 100 lbs. per 100 sq. ft. of floor space, or Master Builders' natural gray "Premixed Mastercron" applied at rate of one pound per sq. ft. of floor space. For use with air-entrained concrete, use Burke Company Non-metallic Floor Hardener Group Order #326 applied at a rate of 75 lbs. per 100 square feet. Burke Sparten Cote Cure-Seal-Hardener shall be used with Burke Non-Metallic Floor Hardener #326.
- R. Liquid Curing Compound. Use "TLF" or "Clear 225 TU" by Hunt Process Company, Burke "Rez-X", or equal conforming to ASTM C309 and providing no detrimental affects with deferred finishes. On surfaces within reservoirs or other concrete structures containing potable water, use nontoxic materials which are free of odor and taste. Provide supporting technical data. Floor hardener treated floors shall use materials only as recommended in writing by hardener manufacturer.
- S. Sheet Curing Materials. ASTM C171, waterproof paper, polyethylene film or white burlap-polyethylene sheet, non-staining.
- T. Vapor Barrier Membrane. Under interior on-grade slabs of occupied areas provide lapped and sealed vapor barrier membrane using Fortiber "Moistop", "Damproof XX" by Nicolet of California, Incorporated, or equal with manufacturer's recommended polyethylene pressure sensitive tape sealant used continuously at lapped joints, penetrations and at perimeter walls or footing surfaces. Throughout, use products and system of single manufacturer.
- U. Gasket Seal for Manhole and Wet Well Precast Concrete Members. Provide gasket seals at mating joint of precast concrete sections. Size gaskets to suit joint dimensions, surface conditions and to assure watertight completed installation. Seal shall consist of either

compressible closed-cell neoprene rods with compatible bonding agent recommended by material manufacturer; of No. 95 extruded butyl rod and No. 2 Primer each produced by General Sealants, Incorporated, City of Industry, California; or equal non-bituminous joint sealing compressible gaskets.

- V. Synthetic Sponge Rubber Filler. Synthetic rubber filler shall be an expanded closed-cell sponge rubber, manufactured from a synthetic polymer neoprene base. The material shall be No. 750.3 Ropax Road Stock as manufactured by the Presstite Division of Interchemical Corporation; Bondtex as manufactured by Rubatex Corporation; or approved equal. The size of the material shall be 25% greater in diameter than the nominal joint width. The manufacturer's instructions for surface preparation and application shall be used as a guide for installation, except that the material shall not be installed by stretching beyond its normal length.
- W. Expansion Joint Filler. Bituminous fiber expansion joint filler shall be in accordance with ASTM D1751. Bituminous expansion joint material shall not be used in joints to be sealed with synthetic rubber sealing compound.
- X. Concrete Expansion Bolts/Deferred Bolting Device (D.B.D.). Except as otherwise specified, where expansion bolts are called for on the Drawings, Parabolt Concrete Anchors as manufactured by the Molly Company, Kwik-Bolts as manufactured by McCulloch Industries, Incorporated, or a concrete anchor by any other manufacturer that shall meet the same Federal Specification requirements and shall equal the performance, shall be used. All bolts thus furnished and used on this project shall be manufactured of stainless steel.

2.02 CONCRETE MIXES.

- A. 28-Day Compressive Strength. It shall be the sole responsibility of the Contractor to mix, place, and cure concrete which shall be of 150 lb./cu. ft. nominal density and which shall attain the compressive strengths at 28 days as designated on Structural Drawings or in these specifications for use in various locations.
- B. Maximum Aggregate Size. Conform to Article 2.01 B.2. For 4,000 psi concrete use 1½ inch maximum size aggregate unless otherwise designated; for 3,000 psi concrete use 1 inch maximum size aggregate; for 2,500 and 2,000 psi concrete use ¾ inch maximum size aggregate. In no case shall the size of the coarse aggregate exceed 75% of the horizontal space between reinforcing bars or between reinforcing bars and forms.
- C. Mix Designs. Conform with requirements of Article 1.04 "Concrete Mix Designs and Preliminary Tests". At least 60 days before any Class concrete is to be placed, the Contractor shall submit for approval for each proposed mix a mix design made by a Civil Engineer registered in Nevada or a Testing Laboratory approved by the Owner.

2.03 CONCRETE MIXING. Concrete shall be ready-mixed, supplied from an off-site commercial ready-mix plant approved by Owner, each load accompanied by a bonded weigh-master's certificate listing the quantity of each concrete ingredient, admixture quantity, water content and slump, and time of loading and departure from ready-mix plant. Also include notations to indicate equipment was checked and found to be free of contaminants prior to batching.

- A. Ready-Mixed Concrete. Unless approved otherwise in advance of batching, all concrete of a single design mix for any one day's pour shall be from a single batch plant of a single supplier. Conform to ASTM C94, except materials, testing and mix design shall be as specified herein. Use transit mixers equipped with automatic devices for recording number of revolutions of drum.