

1
2
3
4
5
6
7
8
9
10
11
12
13
14
15
16
17
18
19
20
21
22
23
24
25
26
27
28

BEFORE THE PUBLIC UTILITIES COMMISSION OF NEVADA

oo0oo

In the Matter of:

Docket No. 24-_____

Application of Great Basin Water Co.,
Pahrump, Spring Creek, Cold Springs,
Pahrump, and Spanish Springs Divisions for
Approval of its 2024 Integrated Resource
Plan and to designate certain system
improvement projects as eligible projects for
which a system improvement rate may be
established, and for relief properly related
thereto.

VOLUME 14 OF 18

Document Description	Page No.
Appendix L-1	2
Appendix L-2	15
Appendix M, Part 1	70

APPENDIX L-1
Funding Plan Analysis (Rate Impact Tables)

TABLE 9-1.a

Pahrump Division Projects	2025	2026	2027	2028	Totals
CVM Consolidation Alt. A					
Initial Plant Costs	\$ -	\$ 161,863	\$ 2,535,857	\$ -	\$ 2,697,720
Escalation of Capital Cost - Inflation	\$ -	\$ 10,994	\$ 229,393	\$ -	\$ 240,386
Subtotal No AFUDC	\$ -	\$ 172,857	\$ 2,765,249	\$ -	\$ 2,938,106
AFUDC	\$ -	\$ 16,050	\$ 98,140	\$ -	\$ 114,189
Total Project Cost per Year	\$ -	\$ 188,907	\$ 2,863,389	\$ -	\$ 3,052,296
Influent Pre-EQ Building Alt. A					
Initial Plant Costs	\$ -	\$ 2,184,671	\$ -	\$ -	\$ 2,184,671
Escalation of Capital Cost - Inflation	\$ -	\$ 136,548	\$ -	\$ -	\$ 136,548
Subtotal No AFUDC	\$ -	\$ 2,321,219	\$ -	\$ -	\$ 2,321,219
AFUDC	\$ -	\$ 82,381	\$ -	\$ -	\$ 82,381
Total Project Cost per Year	\$ -	\$ 2,403,600	\$ -	\$ -	\$ 2,403,600
New Well High Zone					
Initial Plant Costs	\$ 893,409	\$ 1,659,189	\$ -	\$ -	\$ 2,552,598
Escalation of Capital Cost - Inflation	\$ 36,220	\$ 103,704	\$ -	\$ -	\$ 139,924
Subtotal No AFUDC	\$ 929,629	\$ 1,762,893	\$ -	\$ -	\$ 2,692,522
AFUDC	\$ 86,315	\$ 62,566	\$ -	\$ -	\$ 148,881
Total Project Cost per Year	\$ 1,015,944	\$ 1,825,459	\$ -	\$ -	\$ 2,841,403
Sand Filter Rehabilitation Project					
Initial Plant Costs	\$ 543,376	\$ 543,376	\$ -	\$ -	\$ 1,086,752
Escalation of Capital Cost - Inflation	\$ 22,029	\$ 30,214	\$ -	\$ -	\$ 52,243
Subtotal No AFUDC	\$ 565,405	\$ 573,590	\$ -	\$ -	\$ 1,138,995
AFUDC	\$ 32,349	\$ 10,203	\$ -	\$ -	\$ 42,552
Total Project Cost per Year	\$ 597,754	\$ 583,793	\$ -	\$ -	\$ 1,181,548
Total Action Plan Costs - Water	\$ 1,015,944	\$ 2,014,365	\$ 2,863,389	\$ -	\$ 5,893,699
Total Action Plan Costs - Sewer	\$ 597,754	\$ 2,987,394	\$ -	\$ -	\$ 3,585,148
Pahrump Division Alternative Projects					
CVM Consolidation Alt. B					
Initial Plant Costs	\$ -	\$ 244,653	\$ 3,832,899	\$ -	\$ 4,077,552

Escalation of Capital Cost - Inflation	\$	-	\$	16,617	\$	346,723	\$	-	\$	363,339	
Subtotal No AFUDC	\$	-	\$	261,270	\$	4,179,621	\$	-	\$	4,440,891	
AFUDC	\$	-	\$	24,259	\$	148,336	\$	-	\$	172,595	
Total Project Cost per Year	\$	-	\$	285,529	\$	4,327,958	\$	-	\$	4,613,486	
Total Alternative Action Plan Costs - Water	\$	-	\$	285,529	\$	4,327,958	\$	-	\$	4,613,486	\$14,092,333
Total Alternative Action Plan Costs - Sewer	\$	-	\$	-	\$	-	\$	-	\$	-	\$14,092,333

TABLE 9-1.b

Spring Creek Division Projects	2025	2026	2027	2028	Totals
New Well 12					
Initial Plant Costs	\$ -	\$ 771,262	\$ 771,262	\$ -	\$ 1,542,524
Escalation of Capital Cost - Inflation	\$ -	\$ 50,861	\$ 69,768	\$ -	\$ 120,629
Subtotal No AFUDC	\$ -	\$ 822,123	\$ 841,030	\$ -	\$ 1,663,153
AFUDC	\$ -	\$ 80,502	\$ 29,848	\$ -	\$ 110,350
Total Project Cost per Year	\$ -	\$ 902,624	\$ 870,879	\$ -	\$ 1,773,503
Pipeline Replacement Year 1					
Initial Plant Costs	\$ 1,500,000	\$ -	\$ -	\$ -	\$ 1,500,000
Escalation of Capital Cost - Inflation	\$ 57,925	\$ -	\$ -	\$ -	\$ 57,925
Subtotal No AFUDC	\$ 1,557,925	\$ -	\$ -	\$ -	\$ 1,557,925
AFUDC	\$ 41,517	\$ -	\$ -	\$ -	\$ 41,517
Total Project Cost per Year	\$ 1,599,442	\$ -	\$ -	\$ -	\$ 1,599,442
Pipeline Replacement Year 2					
Initial Plant Costs	\$ -	\$ 1,500,000	\$ -	\$ -	\$ 1,500,000
Escalation of Capital Cost - Inflation	\$ -	\$ 93,754	\$ -	\$ -	\$ 93,754
Subtotal No AFUDC	\$ -	\$ 1,593,754	\$ -	\$ -	\$ 1,593,754
AFUDC	\$ -	\$ 56,563	\$ -	\$ -	\$ 56,563
Total Project Cost per Year	\$ -	\$ 1,650,317	\$ -	\$ -	\$ 1,650,317
Pipeline Replacement Year 3					
Initial Plant Costs	\$ -	\$ -	\$ 1,500,000	\$ -	\$ 1,500,000
Escalation of Capital Cost - Inflation	\$ -	\$ -	\$ 135,689	\$ -	\$ 135,689
Subtotal No AFUDC	\$ -	\$ -	\$ 1,635,689	\$ -	\$ 1,635,689
AFUDC	\$ -	\$ -	\$ 58,051	\$ -	\$ 58,051
Total Project Cost per Year	\$ -	\$ -	\$ 1,693,741	\$ -	\$ 1,693,741
Rehab High Zone Water Tank					
Initial Plant Costs	\$ 153,406	\$ 460,217	\$ -	\$ -	\$ 613,622
Escalation of Capital Cost - Inflation	\$ 5,410	\$ 28,765	\$ -	\$ -	\$ 34,174
Subtotal No AFUDC	\$ 158,815	\$ 488,981	\$ -	\$ -	\$ 647,796
AFUDC	\$ 16,955	\$ 17,354	\$ -	\$ -	\$ 34,309
Total Project Cost per Year	\$ 175,770	\$ 506,336	\$ -	\$ -	\$ 682,106
WWTP Reconditioning					

Initial Plant Costs	\$ -	\$ 609,196	\$ -	\$ -	\$ 609,196
Escalation of Capital Cost - Inflation	\$ -	\$ 38,077	\$ -	\$ -	\$ 38,077
Subtotal No AFUDC	\$ -	\$ 647,273	\$ -	\$ -	\$ 647,273
AFUDC	\$ -	\$ 22,972	\$ -	\$ -	\$ 22,972
Total Project Cost per Year	\$ -	\$ 670,244	\$ -	\$ -	\$ 670,244
SCADA Wastewater Upgrades					
Initial Plant Costs	\$ -	\$ 100,000	\$ -	\$ -	\$ 100,000
Escalation of Capital Cost - Inflation	\$ -	\$ 6,594	\$ -	\$ -	\$ 6,594
Subtotal No AFUDC	\$ -	\$ 106,594	\$ -	\$ -	\$ 106,594
AFUDC	\$ -	\$ 2,841	\$ -	\$ -	\$ 2,841
Total Project Cost per Year	\$ -	\$ 109,435	\$ -	\$ -	\$ 109,435
Total Action Plan Plant Costs - Water	\$ 1,775,213	\$ 3,059,277	\$ 2,564,619	\$ -	\$ 7,399,109
Total Action Plan Plant Costs - Sewer	\$ -	\$ 779,680	\$ -	\$ -	\$ 779,680
Spring Creek Division Projects - Alternatives					
Replace High Zone Water Tank					
Initial Plant Costs	\$ 273,706	\$ 821,117	\$ -	\$ -	\$ 1,094,822
Escalation of Capital Cost - Inflation	\$ 9,652	\$ 51,322	\$ -	\$ -	\$ 60,974
Subtotal No AFUDC	\$ 283,357	\$ 872,439	\$ -	\$ -	\$ 1,155,796
AFUDC	\$ 30,251	\$ 30,963	\$ -	\$ -	\$ 61,215
Total Project Cost per Year	\$ 313,609	\$ 903,402	\$ -	\$ -	\$ 1,217,010
Booster Pump Tract 200					
Initial Plant Costs	\$ 155,206	\$ 465,617	\$ -	\$ -	\$ 620,822
Escalation of Capital Cost - Inflation	\$ 5,473	\$ 29,102	\$ -	\$ -	\$ 34,575
Subtotal No AFUDC	\$ 160,679	\$ 494,719	\$ -	\$ -	\$ 655,397
AFUDC	\$ 17,154	\$ 17,558	\$ -	\$ -	\$ 34,712
Total Project Cost per Year	\$ 177,833	\$ 512,277	\$ -	\$ -	\$ 690,109
Rehab WWTP Lift Station					
Initial Plant Costs	\$ 287,356	\$ -	\$ -	\$ -	\$ 287,356
Escalation of Capital Cost - Inflation	\$ 10,133	\$ -	\$ -	\$ -	\$ 10,133
Subtotal No AFUDC	\$ 297,489	\$ -	\$ -	\$ -	\$ 297,489
AFUDC	\$ 10,558	\$ -	\$ -	\$ -	\$ 10,558
Total Project Cost per Year	\$ 308,047	\$ -	\$ -	\$ -	\$ 308,047

Total Alternative Action Plan Costs - Water	\$ 313,609	\$ 903,402	\$ -	\$ -	\$ 1,217,010	\$10,393,955
Total Alternative Action Plan Costs - Sewer	\$ 485,880	\$ 512,277	\$ -	\$ -	\$ 998,156	\$10,393,955

TABLE 9-1.c

Cold Springs Division Projects	2025	2026	2027	2028	Totals
PRV Installation Between Tanks 3 & 4					
Initial Plant Costs	\$ 27,253	\$ 426,968	\$ -	\$ -	\$ 454,221
Escalation of Capital Cost - Inflation	\$ 961	\$ 23,741	\$ -	\$ -	\$ 24,702
Subtotal No AFUDC	\$ 28,214	\$ 450,709	\$ -	\$ -	\$ 478,923
AFUDC	\$ 2,007	\$ 8,017	\$ -	\$ -	\$ 10,024
Total Project Cost per Year	\$ 30,221	\$ 458,726	\$ -	\$ -	\$ 488,947
Rehab Tank1					
Initial Plant Costs	\$ 115,109	\$ 460,438	\$ -	\$ -	\$ 575,547
Escalation of Capital Cost - Inflation	\$ 5,222	\$ 28,779	\$ -	\$ -	\$ 34,001
Subtotal No AFUDC	\$ 120,332	\$ 489,216	\$ -	\$ -	\$ 609,548
AFUDC	\$ 9,648	\$ 17,362	\$ -	\$ -	\$ 27,011
Total Project Cost per Year	\$ 129,980	\$ 506,579	\$ -	\$ -	\$ 636,558
Factory Rehab Tank 2					
Initial Plant Costs	\$ -	\$ 149,910	\$ 599,638	\$ -	\$ 749,548
Escalation of Capital Cost - Inflation	\$ -	\$ 10,924	\$ 54,243	\$ -	\$ 65,167
Subtotal No AFUDC	\$ -	\$ 160,834	\$ 653,881	\$ -	\$ 814,715
AFUDC	\$ -	\$ 12,895	\$ 23,207	\$ -	\$ 36,102
Total Project Cost per Year	\$ -	\$ 173,729	\$ 677,088	\$ -	\$ 850,817
Total Action Plan Costs - Water	\$ 160,201	\$ 1,139,035	\$ 677,088	\$ -	\$ 1,976,323
Cold Springs Division Alternative Projects					
Replace Tank 2					
Initial Plant Costs	\$ -	\$ 212,549	\$ 850,198	\$ -	\$ 1,062,747
Escalation of Capital Cost - Inflation	\$ -	\$ 15,489	\$ 76,909	\$ -	\$ 92,398
Subtotal No AFUDC	\$ -	\$ 228,039	\$ 927,106	\$ -	\$ 1,155,145
AFUDC	\$ -	\$ 18,284	\$ 32,903	\$ -	\$ 51,187
Total Project Cost per Year	\$ -	\$ 246,323	\$ 960,010	\$ -	\$ 1,206,332
Total Alternative Action Plan Costs - Water	\$ -	\$ 246,323	\$ 960,010	\$ -	\$ 1,206,332

\$ 3,182,656

\$ 3,182,656

TABLE 9-1.d

Spanish Springs Division Projects	2025	2026	2027	2028	Totals
Rehab Well 2 (Suki)					
Initial Plant Costs	\$ 170,344	\$ 345,848	\$ -	\$ -	\$ 516,192
Escalation of Capital Cost - Inflation	\$ 6,906	\$ 19,231	\$ -	\$ -	\$ 26,137
Subtotal No AFUDC	\$ 177,250	\$ 365,079	\$ -	\$ -	\$ 542,329
AFUDC	\$ 10,141	\$ 6,494	\$ -	\$ -	\$ 16,635
Total Project Cost per Year	\$ 187,391	\$ 371,573	\$ -	\$ -	\$ 558,964
AMI Meter Replacement Project					
Initial Plant Costs	\$ 100,000	\$ 91,500	\$ 91,500	\$ -	\$ 283,000
Escalation of Capital Cost - Inflation	\$ 4,054	\$ 5,719	\$ 8,277	\$ -	\$ 18,050
Subtotal No AFUDC	\$ 104,054	\$ 97,219	\$ 99,777	\$ -	\$ 301,050
AFUDC	\$ 17,077	\$ 10,379	\$ 3,541	\$ -	\$ 30,998
Total Project Cost per Year	\$ 121,131	\$ 107,598	\$ 103,318	\$ -	\$ 332,048
Rehab Tank 2					
Initial Plant Costs	\$ -	\$ 442,664	\$ -	\$ -	\$ 442,664
Escalation of Capital Cost - Inflation	\$ -	\$ 28,808	\$ -	\$ -	\$ 28,808
Subtotal No AFUDC	\$ -	\$ 471,472	\$ -	\$ -	\$ 471,472
AFUDC	\$ -	\$ 13,617	\$ -	\$ -	\$ 13,617
Total Project Cost per Year	\$ -	\$ 485,090	\$ -	\$ -	\$ 485,090
Total Action Plan Plant Costs - Water	\$ 308,523	\$ 479,171	\$ 103,318	\$ -	\$ 891,012

#REF!
#REF!

Table 9-2.a							
Pahrump Division							
Project	PWRR	Revenue Requirement By Year			Rate Base by Year		
		2025	2026	2027	2025	2026	2027
Pahrump Division Action Plan Projects							
CVM Consolidation Alt. A	\$ 2,931,446	\$ -	\$ -	\$ 23,701	\$ -	\$ -	\$ 3,052,296
Influent Pre-EQ Building Alt. A	\$ 2,445,414	\$ -	\$ 22,694	\$ 250,586	\$ -	\$ 2,403,600	\$ 2,396,266
New Well High Zone	\$ 2,905,494	\$ -	\$ 26,454	\$ 292,235	\$ -	\$ 2,841,403	\$ 2,833,179
Sand Filter Rehabilitation Project	\$ 1,244,975	\$ -	\$ 77,577	\$ 121,537	\$ -	\$ 1,181,548	\$ 1,156,312
Total Pahrump Division Action Plan Projects	\$ 9,527,328	\$ -	\$ 126,724	\$ 688,059	\$ -	\$ 6,426,551	\$ 9,438,053
Pahrump Division Alternative Projects							
CVM Consolidation Alt. B	\$ 4,430,824	\$ -	\$ -	\$ 35,824	\$ -	\$ -	\$ 4,613,486
Total Pahrump Division Alternative Projects	\$ 4,430,824	\$ -	\$ -	\$ 35,824	\$ -	\$ -	\$ 4,613,486

Table 9-2.b							
Spring Creek Division							
Project	PWRR	Revenue Requirement By Year			Rate Base by Year		
		2025	2026	2027	2025	2026	2027
Division Action Plan Projects							
New Well 12	\$ 1,654,177	\$ -	\$ -	\$ 15,042	\$ -	\$ -	\$ 1,773,503
Pipeline Replacement Year 1	\$ 1,719,752	\$ 13,893	\$ 153,957	\$ 140,833	\$ 1,599,442	\$ 1,596,217	\$ 1,557,510
Pipeline Replacement Year 2	\$ 1,656,402	\$ -	\$ 13,382	\$ 148,286	\$ -	\$ 1,650,317	\$ 1,646,989
Pipeline Replacement Year 3	\$ 1,586,888	\$ -	\$ -	\$ 12,820	\$ -	\$ -	\$ 1,693,741
Rehab High Zone Water Tank	\$ 656,690	\$ -	\$ 5,415	\$ 59,955	\$ -	\$ 682,106	\$ 680,730
WWTP Reconditioning	\$ 627,618	\$ -	\$ 6,006	\$ 66,209	\$ -	\$ 670,244	\$ 668,199
SCADA Wastewater Upgrades	\$ 105,534	\$ -	\$ 1,534	\$ 16,798	\$ -	\$ 109,435	\$ 108,638
Total Pahrump Division Action Plan Projects	\$ 8,007,062	\$ 13,893	\$ 180,293	\$ 459,942	\$ 1,599,442	\$ 4,708,320	\$ 8,129,311
Pahrump Division Alternative Projects							
Replace High Zone Water Tank	\$ 1,193,567	\$ -	\$ 9,752	\$ 108,017	\$ -	\$ 1,217,010	\$ 1,214,556
Booster Pump Tract 200	\$ 674,388	\$ -	\$ 6,530	\$ 72,014	\$ -	\$ 690,109	\$ 687,809
Rehab WWTP Lift Station	\$ 330,942	\$ 3,071	\$ 33,913	\$ 30,811	\$ 308,047	\$ 307,107	\$ 295,828
Total Pahrump Division Alternative Projects	\$ 2,198,898	\$ 3,071	\$ 50,195	\$ 210,842	\$ 308,047	\$ 2,214,227	\$ 2,198,193

Table 9-2.c		Revenue Requirement By Year			Rate Base by Year			
Cold Springs Division		PWRR	2025	2026	2027	2025	2026	2027
Project			2025	2026	2027	2025	2026	2027
Cold Springs Division Action Plan Projects								
PRV Installation Between Tanks 3 & 4	\$	534,223	\$ -	\$ 28,711	\$ 45,243	\$ -	\$ 488,947	\$ 482,045
Rehab Tank1	\$	653,654	\$ -	\$ 5,291	\$ 58,626	\$ -	\$ 636,558	\$ 635,275
Factory Rehab Tank 2	\$	815,543	\$ -	\$ -	\$ 6,601	\$ -	\$ -	\$ 850,817
Total Cold Springs Division Action Plan Projects	\$	2,003,421	\$ -	\$ 34,002	\$ 110,470	\$ -	\$ 1,125,506	\$ 1,968,137
Cold Springs Division Alternative Projects								
Replace Tank 2	\$	1,156,319	\$ -	\$ -	\$ 9,360	\$ -	\$ -	\$ 1,206,332
Total Cold Springs Division Alternative Projects	\$	1,156,319	\$ -	\$ -	\$ 9,360	\$ -	\$ -	\$ 1,206,332

Table 9-2.d		Revenue Requirement By Year			Rate Base by Year			
Spanish Springs Division		PWRR	2025	2026	2027	2025	2026	2027
Project			2025	2026	2027	2025	2026	2027
Spanish Springs Division Action Plan Projects								
Rehab Well 2 (Suki)	\$ 600,496	\$ -	\$ 36,904	\$ 57,837	\$ -	\$ 558,964	\$ 547,639	
AMI Meter Replacement Project	\$ 375,551	\$ -	\$ -	\$ 3,686	\$ -	\$ -	\$ 332,048	
Rehab Tank 2	\$ 512,755	\$ -	\$ 8,262	\$ 45,731	\$ -	\$ 485,090	\$ 483,133	
Total Spanish Springs Division Action Plan Projects	\$ 1,488,803	\$ -	\$ 45,165	\$ 107,254	\$ -	\$ 1,044,053	\$ 1,362,819	

APPENDIX L-2

Funding Plan Analysis (System Improvement Rate Tables)

GBWC 2024 INTEGRATED RESOURCE PLAN
Cold Springs Division - Factory Rehab Tank 2 SIR Impact
Future Value Revenue Requirement
Appendix L-2.CS.2.1

		<u>Tank</u>	<u>Ref</u>	<u>Calc</u>
Plant in Service	\$	850,817	A	
Useful Life (Years)		<u>50</u>	B	
Depr Expense	\$	<u>17,016</u>	C	A/B

From Cert Filing of Docket 21-12025		
Debt	Equity	ROR
2.359%	4.768%	7.127%
Ref	D	E

			<u>Ref</u>	<u>Calc</u>
Debt Portion of RR	\$	20,071	F	A*D
Equity Portion of RR	\$	40,567	G	A*E
Gross up for Federal Income Tax	\$	10,784	H	G / (1-0.21) - G
RR Less Depreciation & Mill Tax	\$	71,421	I	F+G+H
Depreciation	\$	17,016	B	
Mill Tax	\$	<u>339</u>	J	(I+B)*0.00303/(1-0.21)
First Year RR	\$	<u>88,777</u>	K	I+B+J

GBWC 2024 INTEGRATED RESOURCE PLAN
Cold Springs Division - Factory Rehab Tank 2 SIR Impact
System Improvement Rate - Rate Design
Appendix L-2.CS.2.2

<u>Total SIR Revenue Requirement</u>	\$	<u>88,777</u>	From Revenue Requirement
--------------------------------------	----	---------------	--------------------------

<u>Expected 12 Month Consumption (gallons)</u>	<u>450,057,365</u>	Based on consumption and customer count as of May 2023
--	--------------------	--

Rate Design*

<u>Customer Class</u>	<u>Rate per 1,000 gallons</u>
Residential	\$ 0.20
Mult-Res	\$ 0.20
Non-Residential	\$ 0.20
Irrigation	\$ 0.20

*Calculation References

Revenue requirement divided by (Total Annualized Consumption / 1,000)

GBWC 2024 INTEGRATED RESOURCE PLAN
Cold Springs Division - Factory Rehab Tank 2 SIR Impact
Customer Usage and Counts
Appendix L-2.CS.2.3

	<u>Customers</u>	<u>Annualized Consumption</u>
Cold Springs Water	3,849	450,057,365
Spanish Springs Water	582	171,565,573
Spring Creek Water	5,066	760,377,111
Pahrump Water	6,474	919,066,906
Pahrump Water x Irrigation Transimission	6,439	781,517,308
Pahrump Sewer	4,575	
Spring Creek Sewer	149	

Source: May 31, 2023 Usage and Customer Counts

GBWC 2024 INTEGRATED RESOURCE PLAN
Cold Springs Division - Replace Tank 2 SIR Impact
Future Value Revenue Requirement
Appendix L-2.CS.1.1

		<u>Tank</u>	<u>Ref</u>	<u>Calc</u>
Plant in Service	\$	1,206,332	A	
Useful Life (Years)		<u>50</u>	B	
Depr Expense	\$	<u>24,127</u>	C	A/B

From Cert Filing of Docket 21-12025		
Debt	Equity	ROR
2.359%	4.768%	7.127%
Ref	D	E

			<u>Ref</u>	<u>Calc</u>
Debt Portion of RR	\$	28,457	F	A*D
Equity Portion of RR	\$	57,518	G	A*E
Gross up for Federal Income Tax	\$	<u>15,290</u>	H	G / (1-0.21) - G
RR Less Depreciation & Mill Tax	\$	101,265	I	F+G+H
Depreciation	\$	24,127	B	
Mill Tax	\$	<u>481</u>	J	(I+B)*0.00303/(1-0.21)
First Year RR	\$	<u>125,872</u>	K	I+B+J

GBWC 2024 INTEGRATED RESOURCE PLAN
Cold Springs Division - Replace Tank 2 SIR Impact
System Improvement Rate - Rate Design
Appendix L-2.CS.1.2

<u>Total SIR Revenue Requirement</u>	\$	125,872	From Revenue Requirement
--------------------------------------	----	---------	--------------------------

<u>Expected 12 Month Consumption (gallons)</u>	450,057,365	Based on consumption and customer count as of May 2023
--	-------------	--

Rate Design*

<u>Customer Class</u>	<u>Rate per 1,000 gallons</u>
Residential	\$ 0.28
Multi-Residential	\$ 0.28
Non-Residential	\$ 0.28
Irrigation	\$ 0.28

*Calculation References

Revenue requirement divided by (Total Annualized Consumption / 1,000)

GBWC 2024 INTEGRATED RESOURCE PLAN
 Cold Springs Division - Replace Tank 2 SIR Impact
 Customer Usage and Counts
 Appendix L-2.CS.1.3

	<u>Customers</u>	<u>Annualized Consumption</u>
Cold Springs Water	3,849	450,057,365
Spanish Springs Water	582	171,565,573
Spring Creek Water	5,066	760,377,111
Pahrump Water	6,474	919,066,906
Pahrump Water x Irrigation Transimission	6,439	781,517,308
Pahrump Sewer	4,575	
Spring Creek Sewer	149	

Source: May 31, 2023 Usage and Customer Counts

	<u>Rev Req</u>	<u>Rate per 1,000 gallons</u>
CVM Consolidation Alt A SIR Impact	318,486 \$	0.41
New Well High Zone SIR Impact	334,511 \$	0.43
Total	652,998	0.84

	<u>Influent Pre EQ Building Repairs</u>	<u>Sand Filter Rehab</u>	<u>Total</u>
<u>Rev Req</u>	288,715	141,925	430,640
Rate Design			
5/8"	\$3.58	1.76	\$5.34
3/4"	\$3.58	1.76	\$5.34
1"	\$3.58	1.76	\$5.34
1.5"	\$21.82	10.73	\$32.55
2"	\$31.51	15.49	\$47.00
3"	\$82.71	40.66	\$123.36
4"	\$118.25	58.13	\$176.38
6"	\$148.85	73.17	\$222.03
8"	\$216.30	106.33	\$322.63
10"*	\$1,670.24	821.05	\$2,491.29
*10" per Bed	\$1.56	\$0.77	\$2.32

GBWC 2024 INTEGRATED RESOURCE PLAN
Pahrump Division - CVM Consolidation Alt A SIR Impact
Future Value Revenue Requirement
Appendix L-2.P.2.1

		<u>Tank</u>	<u>Ref</u>	<u>Calc</u>
Plant in Service	\$	3,052,296	A	
Useful Life (Years)		<u>50</u>	B	
Depr Expense	\$	<u>61,046</u>	C	A/B

From Cert Filing of Docket 21-12025		
Debt	Equity	ROR
2.359%	4.768%	7.127%
Ref	D	E

			<u>Ref</u>	<u>Calc</u>
Debt Portion of RR	\$	72,004	F	A*D
Equity Portion of RR	\$	145,533	G	A*E
Gross up for Federal Income Tax	\$	<u>38,686</u>	H	G / (1-0.21) - G
RR Less Depreciation & Mill Tax	\$	256,223	I	F+G+H
Depreciation	\$	61,046	B	
Mill Tax	\$	<u>1,217</u>	J	(I+B)*0.00303/(1-0.21)
First Year RR	\$	<u>318,486</u>	K	I+B+J

GBWC 2024 INTEGRATED RESOURCE PLAN
Pahrump Division - CVM Consolidation Alt A SIR Impact
System Improvement Rate - Rate Design
Appendix L-2.P.2.2

<u>Total SIR Revenue Requirement</u>	\$	318,486	From Revenue Requirement
--------------------------------------	----	---------	--------------------------

<u>Expected 12 Month Consumption (gallons)</u>	781,517,308	Based on consumption and customer count as of May 2023
--	-------------	--

Rate Design*

<u>Customer Class</u>	<u>Rate per 1,000 gallons</u>
Residential	\$ 0.41
Multi-Res	\$ 0.41
Non-Residential	\$ 0.41
Irrigation	\$ 0.41

*Calculation References

Revenue requirement divided by (Total Annualized Consumption / 1,000)

GBWC 2024 INTEGRATED RESOURCE PLAN
Pahrump Division - CVM Consolidation Alt A SIR Impact
Customer Usage and Counts
Appendix L-2.P.2.3

	<u>Customers</u>	<u>Annualized Consumption</u>
Cold Springs Water	3,849	450,057,365
Spanish Springs Water	582	171,565,573
Spring Creek Water	5,066	760,377,111
Pahrump Water	6,474	919,066,906
Pahrump Water x Irrigation Transimission	6,439	781,517,308
Pahrump Sewer	4,575	
Spring Creek Sewer	149	

Source: May 31, 2023 Usage and Customer Counts

GBWC 2024 INTEGRATED RESOURCE PLAN
Pahrump Division - Influent Pre EQ Building Repairs Alt. A SIR Impact
Future Value Revenue Requirement
Appendix L-2.P.3.1

Plant in Service	\$ 2,403,600	<u>Ref</u> <u>Calc</u>
		A
Useful Life (Years)	<u>28</u>	B
Depr Expense	<u>\$ 85,843</u>	C A/B

From Cert Filing of Docket 21-12025		
Debt	Equity	ROR
2.359%	4.768%	7.127%
<i>Ref</i>	<i>D</i>	<i>E</i>

		<u>Ref</u> <u>Calc</u>
Debt Portion of RR	\$ 56,701	F A*D
Equity Portion of RR	\$ 114,604	G A*E
Gross up for Federal Income Tax	\$ 30,464	H $G / (1-0.21) - G$
RR Less Depreciation & Mill Tax	\$ 201,769	I F+G+H
Depreciation	\$ 85,843	B
Mill Tax	\$ 1,103	J $(I+B)*0.00303/(1-0.21)$
First Year RR	\$ 288,715	K I+B+J

GBWC 2024 INTEGRATED RESOURCE PLAN
Pahrump Division - Influent Pre EQ Building Repairs Alt. A SIR Impact
System Improvement Rate - Rate Design
Appendix L-2.P.3.2

Total SIR Revenue Requirement	\$	288,715	<i>From Revenue Requirement</i>
--------------------------------------	-----------	----------------	---------------------------------

Total Annualized Customers X 12 Months		-	
---	--	---	--

Rate Design*

<u>Customer Class</u>	<u>Meter Size</u>	<u>Annual Rev Requirem</u>	<u>Rate/Customer/Month</u>
Residential	5/8"	\$50,149.41	\$3.58
Residential	3/4"	\$53,458.35	\$3.58
Residential	1"	\$80,316.45	\$3.58
Residential	1.5"	\$785.48	\$21.82
Residential	2"	\$10,965.40	\$31.51
Residential	3"	\$992.47	\$82.71
Non-Residential	5/8"	\$85.97	\$3.58
Non-Residential	3/4"	\$85.97	\$3.58
Non-Residential	1"	\$5,844.35	\$3.58
Non-Residential	1.5"	\$4,189.31	\$21.82
Non-Residential	2"	\$32,140.02	\$31.51
Non-Residential	3"	\$6,947.27	\$82.71
Non-Residential	4"	\$11,352.23	\$118.25
Non-Residential	6"	\$3,572.48	\$148.85
Non-Residential	8"	\$7,786.78	\$216.30
Non-Residential	10"	\$20,042.91	\$1,670.24 <i>Equal to \$1.56 per bed for the CCA. CCA has 1,072 beds</i>

GBWC 2024 INTEGRATED RESOURCE PLAN
Pahrump Division - Sand Filter Rehab SIR Impact
System Improvement Rate - Revenue Allocation
Appendix L-2.P.3.3

		<u>Customer</u>	<u>Current R</u>	<u>Annual Rev</u>	<u>% Of Rev</u>
Residential	5/8"	1,167	56.61	\$792,766	17.37%
Residential	3/4"	1,244	56.61	\$845,074	18.52%
Residential	1"	1,869	56.61	\$1,269,649	27.82%
Residential	1.5"	3	344.92	\$12,417	0.27%
Residential	2"	29	498.11	\$173,342	3.80%
Residential	3"	1	1,307.42	\$15,689	0.34%
Non-Residential	5/8"	2	56.61	\$1,359	0.03%
Non-Residential	3/4"	2	56.61	\$1,359	0.03%
Non-Residential	1"	136	56.61	\$92,388	2.02%
Non-Residential	1.5"	16	344.92	\$66,225	1.45%
Non-Residential	2"	85	498.11	\$508,072	11.13%
Non-Residential	3"	7	1,307.42	\$109,823	2.41%
Non-Residential	4"	8	1,869.34	\$179,457	3.93%
Non-Residential	6"	2	2,353.08	\$56,474	1.24%
Non-Residential	8"	3	3,419.29	\$123,094	2.70%
Non-Residential	10"	1	26,403.36	\$316,840	6.94%

Source: Company records as of May 31, 2023

GBWC 2024 INTEGRATED RESOURCE PLAN
Pahrump Division - New Well High Zone SIR Impact
Future Value Revenue Requirement
Appendix L-2.P.1.1

	<u>Tank</u>	<u>Ref</u>	<u>Calc</u>
Plant in Service	\$ 2,841,403	A	
Useful Life (Years)	<u>30</u>	B	
Depr Expense	<u>\$ 94,713</u>	C	A/B

From Cert Filing of Docket 21-12025		
	Debt	Equity
	2.359%	4.768%
ROR		7.127%
Ref	D	E

		<u>Ref</u>	<u>Calc</u>
Debt Portion of RR	\$ 67,029	F	A*D
Equity Portion of RR	\$ 135,478	G	A*E
Gross up for Federal Income Tax	\$ 36,013	H	G / (1-0.21) - G
RR Less Depreciation & Mill Tax	\$ 238,520	I	F+G+H
Depreciation	\$ 94,713	B	
Mill Tax	<u>\$ 1,278</u>	J	(I+B)*0.00303/(1-0.21)
First Year RR	<u>\$ 334,511</u>	K	I+B+J

GBWC 2024 INTEGRATED RESOURCE PLAN
Pahrump Division - New Well High Zone SIR Impact
System Improvement Rate - Rate Design
Appendix L-2.P.1.2

Total SIR Revenue Requirement	\$	334,511	From Revenue Requirement
--------------------------------------	-----------	----------------	--------------------------

Expected 12 Month Consumption (gallons)		781,517,308	Based on consumption and customer count as of May 2023
--	--	--------------------	--

Rate Design*

Customer Class	\$	Rate per 1,000 gallons
Residential	\$	0.43
Multi-Res	\$	0.43
Non-Residential	\$	0.43
Irrigation	\$	0.43

***Calculation References**

Revenue requirement divided by (Total Annualized Consumption / 1,000)

GBWC 2024 INTEGRATED RESOURCE PLAN
Pahrump Division - New Well High Zone SIR Impact
Customer Usage and Counts
Appendix L-2.P.1.3

	<u>Customers</u>	<u>Annualized Consumption</u>
Cold Springs Water	3,849	450,057,365
Spanish Springs Water	582	171,565,573
Spring Creek Water	5,066	760,377,111
Pahrump Water	6,474	919,066,906
Pahrump Water x Irrigation Transimission	6,439	781,517,308
Pahrump Sewer	4,575	
Spring Creek Sewer	149	

Source: May 31, 2023 Usage and Customer Counts

GBWC 2024 INTEGRATED RESOURCE PLAN
Pahrump Division - Sand Filter Rehab SIR Impact
Future Value Revenue Requirement
Appendix L-2.P.4.1

		<u>Ref</u>	<u>Calc</u>
Plant in Service	\$ 1,181,548	A	
Useful Life (Years)	<u>28</u>	B	
Depr Expense	<u>\$ 42,198</u>	C	A/B

From Cert Filing of Docket 21-12025		
	Debt	Equity
	2.359%	4.768%
ROR		7.127%
Ref	D	E

		<u>Ref</u>	<u>Calc</u>
Debt Portion of RR	\$ 27,873	F	A*D
Equity Portion of RR	\$ 56,336	G	A*E
Gross up for Federal Income Tax	\$ 14,975	H	G / (1-0.21) - G
RR Less Depreciation & Mill Tax	\$ 99,184	I	F+G+H
Depreciation	\$ 42,198	B	
Mill Tax	<u>\$ 542</u>	J	(I+B)*0.00303/(1-0.21)
First Year RR	<u>\$ 141,925</u>	K	I+B+J

GBWC 2024 INTEGRATED RESOURCE PLAN
Pahrump Division - Sand Filter Rehab SIR Impact
System Improvement Rate - Rate Design
Appendix L-2.P.4.2

Total SIR Revenue Requirement	\$	141,925	From Revenue Requirement
--------------------------------------	-----------	----------------	--------------------------

Rate Design

Customer Class	Meter Size	Annual Rev Requirement	Rate/Customer/Month	
Residential	5/8"	\$ 24,652.16	1.76	
Residential	3/4"	\$ 26,278.74	1.76	
Residential	1"	\$ 39,481.48	1.76	
Residential	1.5"	\$ 386.13	10.73	
Residential	2"	\$ 5,390.32	15.49	
Residential	3"	\$ 487.87	40.66	
Non-Residential	5/8"	\$ 42.25	1.76	
Non-Residential	3/4"	\$ 42.25	1.76	
Non-Residential	1"	\$ 2,872.92	1.76	
Non-Residential	1.5"	\$ 2,059.35	10.73	
Non-Residential	2"	\$ 15,799.20	15.49	
Non-Residential	3"	\$ 3,415.11	40.66	
Non-Residential	4"	\$ 5,580.45	58.13	
Non-Residential	6"	\$ 1,756.13	73.17	
Non-Residential	8"	\$ 3,827.79	106.33	
Non-Residential	10"	\$ 9,852.59	821.05	Equal to 0.77 per bed for the CCA. CCA has 1,072 beds

GBWC 2024 INTEGRATED RESOURCE PLAN
Pahrump Division - Sand Filter Rehab SIR Impact
System Improvement Rate - Revenue Allocation
Appendix L-2.P.4.3

	<u>Customer Count</u>	<u>Current Rate</u>	<u>Annual Rev</u>	<u>% Of Rev</u>
Residential 5/8"	1,167	56.61	\$ 792,766	17.4%
Residential 3/4"	1,244	56.61	\$ 845,074	18.5%
Residential 1"	1,869	56.61	\$ 1,269,649	27.8%
Residential 1.5"	3	344.92	\$ 12,417	0.3%
Residential 2"	29	498.11	\$ 173,342	3.8%
Residential 3"	1	1,307.42	\$ 15,689	0.3%
Non-Reside 5/8"	2	56.61	\$ 1,359	0.0%
Non-Reside 3/4"	2	56.61	\$ 1,359	0.0%
Non-Reside 1"	136	56.61	\$ 92,388	2.0%
Non-Reside 1.5"	16	344.92	\$ 66,225	1.5%
Non-Reside 2"	85	498.11	\$ 508,072	11.1%
Non-Reside 3"	7	1,307.42	\$ 109,823	2.4%
Non-Reside 4"	8	1,869.34	\$ 179,457	3.9%
Non-Reside 6"	2	2,353.08	\$ 56,474	1.2%
Non-Reside 8"	3	3,419.29	\$ 123,094	2.7%
Non-Reside 10"	1	26,403.36	\$ 316,840	6.9%

Source: Company records as of May 31, 2023

GBWC 2024 INTEGRATED RESOURCE PLAN
Pahrump Division - CVM Consolidation Alt B SIR Impact
Future Value Revenue Requirement
Appendix L-2.P.5.1

	<u>Tank</u>	<u>Ref</u>	<u>Calc</u>
Plant in Service	\$ 4,613,486	A	
Useful Life (Years)	<u>50</u>	B	
Depr Expense	<u>\$ 92,270</u>	C	A/B

From Cert Filing of Docket 21-12025		
	Debt	Equity
	2.359%	4.768%
ROR		7.127%
Ref	D	E

	<u>Ref</u>	<u>Calc</u>
Debt Portion of RR \$ 108,832	F	A*D
Equity Portion of RR \$ 219,971	G	A*E
Gross up for Federal Income Tax \$ 58,473	H	G / (1-0.21) - G
RR Less Depreciation & Mill Tax \$ 387,276	I	F+G+H
Depreciation \$ 92,270	B	
Mill Tax \$ 1,839	J	(I+B)*0.00303/(1-0.21)
First Year RR \$ 481,385	K	I+B+J

GBWC 2024 INTEGRATED RESOURCE PLAN
Pahrump Division - CVM Consolidation Alt B SIR Impact
System Improvement Rate - Rate Design
Appendix L-2.P.5.2

Total SIR Revenue Requirement	\$	481,385	From Revenue Requirement
--------------------------------------	-----------	----------------	--------------------------

Expected 12 Month Consumption (gallons)		781,517,308	Based on consumption and customer count as of May 2023
--	--	--------------------	--

Rate Design*

<u>Customer Class</u>	<u>Rate per 1,000 gallons</u>
Residential	\$ 0.62
Multi-Res	\$ 0.62
Non-Residential	\$ 0.62
Irrigation	\$ 0.62

*Calculation References

Revenue requirement divided by (Total Annualized Consumption / 1,000)

GBWC 2024 INTEGRATED RESOURCE PLAN
Pahrump Division - CVM Consolidation Alt B SIR Impact
Customer Usage and Counts
Appendix L-2.P.5.3

	<u>Customers</u>	<u>Annualized Consumption</u>
Cold Springs Water	3,849	450,057,365
Spanish Springs Water	582	171,565,573
Spring Creek Water	5,066	760,377,111
Pahrump Water	6,474	919,066,906
Pahrump Water x Irrigation Transimission	6,439	781,517,308
Pahrump Sewer	4,575	
Spring Creek Sewer	149	

Source: May 31, 2023 Usage and Customer Counts

GBWC 2024 INTEGRATED RESOURCE PLAN
 Spanish Springs Division - Rehab Well 2 (Suki) SIR Impact
 Future Value Revenue Requirement
 Appendix L-2.SS.1.1

		<u>Tank</u>	<u>Ref</u>	<u>Calc</u>
Plant in Service	\$	558,964	A	
Useful Life (Years)		<u>30</u>	B	
Depr Expense	\$	<u>18,632</u>	C	A/B

From Cert Filing of Docket 21-12025		
Debt	Equity	ROR
2.359%	4.768%	7.127%
Ref	D	E

			<u>Ref</u>	<u>Calc</u>
Debt Portion of RR	\$	13,186	F	A*D
Equity Portion of RR	\$	26,651	G	A*E
Gross up for Federal Income Tax	\$	7,085	H	G / (1-0.21) - G
RR Less Depreciation & Mill Tax	\$	46,922	I	F+G+H
Depreciation	\$	18,632	B	
Mill Tax	\$	251	J	(I+B)*0.00303/(1-0.21)
First Year RR	\$	<u>65,805</u>	K	I+B+J

GBWC 2024 INTEGRATED RESOURCE PLAN
 Spanish Springs Division - Rehab Well 2 (Suki) SIR Impact
 System Improvement Rate - Rate Design
 Appendix L-2.SS.1.2

Total SIR Revenue Requirement	\$ 65,805	From Revenue Requirement
-------------------------------	-----------	--------------------------

Expected 12 Month Consumption (gallons)	171,565,573	Based on consumption and customer count as of May 2023
---	-------------	--

Rate Design*

<u>Customer Class</u>		<u>Rate per 1,000 gallons</u>
Residential	\$	0.38
Multi-Res	\$	0.38
Non-Residential	\$	0.38
Irrigation	\$	0.38

*Calculation References

Revenue requirement divided by (Total Annualized Consumption / 1,000)

GBWC 2024 INTEGRATED RESOURCE PLAN
 Spanish Springs Division - Rehab Well 2 (Suki) SIR Impact
 Customer Usage and Counts
 Appendix L-2.SS.1.3

	<u>Customers</u>	<u>Annualized Consumption</u>
Cold Springs Water	3,849	450,057,365
Spanish Springs Water	582	171,565,573
Spring Creek Water	5,066	760,377,111
Pahrump Water	6,474	919,066,906
Pahrump Water x Irrigation Transimission	6,439	781,517,308
Pahrump Sewer	4,575	
Spring Creek Sewer	149	

Source: May 31, 2023 Usage and Customer Counts

	<u>Rev Req</u>	<u>Rate Impact per 1,000 gallons</u>
New Well 12	208,790	0.27
Pipeline Year 1	166,891	0.22
Pipeline Year 2	172,199	0.23
Pipeline Year 3	176,730	0.23
High Tank	71,173	0.09
Total	795,783	1.05

GBWC 2024 INTEGRATED RESOURCE PLAN
 Spring Creek Division - New Well 12 SIR Impact
 Future Value Revenue Requirement
 Appendix L-2.SC.1.1

		<u>Tank</u>	<u>Ref</u>	<u>Calc</u>
Plant in Service	\$	1,773,503	A	
Useful Life (Years)		<u>30</u>	B	
Depr Expense	\$	<u>59,117</u>	C	A/B

From Cert Filing of Docket 21-12025		
Debt	Equity	ROR
2.359%	4.768%	7.127%
Ref	D	E

			<u>Ref</u>	<u>Calc</u>
Debt Portion of RR	\$	41,837	F	A*D
Equity Portion of RR	\$	84,561	G	A*E
Gross up for Federal Income Tax	\$	<u>22,478</u>	H	G / (1-0.21) - G
RR Less Depreciation & Mill Tax	\$	148,876	I	F+G+H
Depreciation	\$	59,117	B	
Mill Tax	\$	<u>798</u>	J	(I+B)*0.00303/(1-0.21)
First Year RR	\$	<u>208,790</u>	K	I+B+J

GBWC 2024 INTEGRATED RESOURCE PLAN
 Spring Creek Division - New Well 12 SIR Impact
 System Improvement Rate - Rate Design
 Appendix L-2.SC.1.2

Total SIR Revenue Requirement	\$ 208,790	From Revenue Requirement
-------------------------------	------------	--------------------------

Expected 12 Month Consumption (gallons)	760,377,111	Based on consumption and customer count as of May 2023
---	-------------	--

Rate Design*

<u>Customer Class</u>		<u>Rate per 1,000 gallons</u>
Residential	\$	0.27
Multi-Res	\$	0.27
Non-Residential	\$	0.27
Irrigation	\$	0.27

*Calculation References

Revenue requirement divided by (Total Annualized Consumption / 1,000)

GBWC 2024 INTEGRATED RESOURCE PLAN
Spring Creek Division - New Well 12 SIR Impact
Customer Usage and Counts
Appendix L-2.SC.1.3

	<u>Customers</u>	<u>Annualized Consumption</u>
Cold Springs Water	3,849	450,057,365
Spanish Springs Water	582	171,565,573
Spring Creek Water	5,066	760,377,111
Pahrump Water	6,474	919,066,906
Pahrump Water x Irrigation Transimission	6,439	781,517,308
Pahrump Sewer	4,575	
Spring Creek Sewer	149	

Source: May 31, 2023 Usage and Customer Counts

GBWC 2024 INTEGRATED RESOURCE PLAN
 Spring Creek Division - Pipe Replacement Year 1 SIR Impact
 Future Value Revenue Requirement
 Appendix L-2.SC.2.1

		<u>Tank</u>	<u>Ref</u>	<u>Calc</u>
Plant in Service	\$	1,599,442	A	
Useful Life (Years)		<u>50</u>	B	
Depr Expense	\$	<u>31,989</u>	C	A/B

From Cert Filing of Docket 21-12025		
Debt	Equity	ROR
2.359%	4.768%	7.127%
Ref	D	E

			<u>Ref</u>	<u>Calc</u>
Debt Portion of RR	\$	37,731	F	A*D
Equity Portion of RR	\$	76,261	G	A*E
Gross up for Federal Income Tax	\$	<u>20,272</u>	H	G / (1-0.21) - G
RR Less Depreciation & Mill Tax	\$	134,264	I	F+G+H
Depreciation	\$	31,989	B	
Mill Tax	\$	<u>638</u>	J	(I+B)*0.00303/(1-0.21)
First Year RR	\$	<u>166,891</u>	K	I+B+J

GBWC 2024 INTEGRATED RESOURCE PLAN
Spring Creek Division - Pipe Replacement Year 1 SIR Impact
System Improvement Rate - Rate Design
Appendix L-2.SC.2.2

<u>Total SIR Revenue Requirement</u>	\$	166,891	From Revenue Requirement
--------------------------------------	----	---------	--------------------------

<u>Expected 12 Month Consumption (gallons)</u>	760,377,111	Based on consumption and customer count as of May 2023
--	-------------	--

Rate Design*

<u>Customer Class</u>	<u>Rate per 1,000 gallons</u>
Residential	\$ 0.22
Multi-Res	\$ 0.22
Non-Residential	\$ 0.22
Irrigation	\$ 0.22

*Calculation References

Revenue requirement divided by (Total Annualized Consumption / 1,000)

GBWC 2024 INTEGRATED RESOURCE PLAN
Spring Creek Division - Pipe Replacement Year 1 SIR Impact
Customer Usage and Counts
Appendix L-2.SC.2.3

	<u>Customers</u>	<u>Annualized Consumption</u>
Cold Springs Water	3,849	450,057,365
Spanish Springs Water	582	171,565,573
Spring Creek Water	5,066	760,377,111
Pahrump Water	6,474	919,066,906
Pahrump Water x Irrigation Transimission	6,439	781,517,308
Pahrump Sewer	4,575	
Spring Creek Sewer	149	

Source: May 31, 2023 Usage and Customer Counts

GBWC 2024 INTEGRATED RESOURCE PLAN
 Spring Creek Division - Pipe Replacement Year 2 SIR Impact
 Future Value Revenue Requirement
 Appendix L-2.SC.3.1

	<u>Tank</u>	<u>Ref</u>	<u>Calc</u>
Plant in Service	\$ 1,650,317	A	
Useful Life (Years)	<u>50</u>	B	
Depr Expense	<u>\$ 33,006</u>	C	A/B

From Cert Filing of Docket 21-12025		
Debt	Equity	ROR
2.359%	4.768%	7.127%
Ref	D	E

		<u>Ref</u>	<u>Calc</u>
Debt Portion of RR	\$ 38,931	F	A*D
Equity Portion of RR	\$ 78,687	G	A*E
Gross up for Federal Income Tax	\$ 20,917	H	G / (1-0.21) - G
RR Less Depreciation & Mill Tax	\$ 138,535	I	F+G+H
Depreciation	\$ 33,006	B	
Mill Tax	\$ 658	J	(I+B)*0.00303/(1-0.21)
First Year RR	<u>\$ 172,199</u>	K	I+B+J

GBWC 2024 INTEGRATED RESOURCE PLAN
 Spring Creek Division - Pipe Replacement Year 2 SIR Impact
 System Improvement Rate - Rate Design
 Appendix L-2.SC.3.2

<u>Total SIR Revenue Requirement</u>	\$	172,199	From Revenue Requirement
--------------------------------------	----	---------	--------------------------

<u>Expected 12 Month Consumption (gallons)</u>	760,377,111	Based on consumption and customer count as of May 2023
--	-------------	--

Rate Design*

<u>Customer Class</u>	<u>Rate per 1,000 gallons</u>
Residential	\$ 0.23
Multi-Res	\$ 0.23
Non-Residential	\$ 0.23
Irrigation	\$ 0.23

*Calculation References

Revenue requirement divided by (Total Annualized Consumption / 1,000)

GBWC 2024 INTEGRATED RESOURCE PLAN
Spring Creek Division - Pipe Replacement Year 2 SIR Impact
Customer Usage and Counts
Appendix L-2.SC.3.3

	<u>Customers</u>	<u>Annualized Consumption</u>
Cold Springs Water	3,849	450,057,365
Spanish Springs Water	582	171,565,573
Spring Creek Water	5,066	760,377,111
Pahrump Water	6,474	919,066,906
Pahrump Water x Irrigation Transimission	6,439	781,517,308
Pahrump Sewer	4,575	
Spring Creek Sewer	149	

Source: May 31, 2023 Usage and Customer Counts

GBWC 2024 INTEGRATED RESOURCE PLAN
 Spring Creek Division - Pipe Replacement Year 3 SIR Impact
 Future Value Revenue Requirement
 Appendix L-2.SC.4.1

	<u>Tank</u>	<u>Ref</u>	<u>Calc</u>
Plant in Service	\$ 1,693,741	A	
Useful Life (Years)	<u>50</u>	B	
Depr Expense	<u>\$ 33,875</u>	C	A/B

From Cert Filing of Docket 21-12025		
	Debt	Equity
	2.359%	4.768%
ROR		7.127%
Ref	D	E

	<u>Ref</u>	<u>Calc</u>
Debt Portion of RR \$ 39,955	F	A*D
Equity Portion of RR \$ 80,758	G	A*E
Gross up for Federal Income Tax \$ 21,467	H	$G / (1-0.21) - G$
RR Less Depreciation & Mill Tax \$ 142,180	I	F+G+H
Depreciation \$ 33,875	B	
Mill Tax \$ 675	J	$(I+B)*0.00303/(1-0.21)$
First Year RR \$ 176,730	K	I+B+J

GBWC 2024 INTEGRATED RESOURCE PLAN
Spring Creek Division - Pipe Replacement Year 3 SIR Impact
System Improvement Rate - Rate Design
Appendix L-2.SC.4.2

Total SIR Revenue Requirement	\$	176,730	From Revenue Requirement
--------------------------------------	-----------	----------------	--------------------------

Expected 12 Month Consumption (gallons)	760,377,111	Based on consumption and customer count as of May 2023
--	--------------------	--

Rate Design*

Customer Class	Rate per 1,000 gallons
Residential	\$ 0.23
Multi-Res	\$ 0.23
Non-Residential	\$ 0.23
Irrigation	\$ 0.23

*Calculation References

Revenue requirement divided by (Total Annualized Consumption / 1,000)

GBWC 2024 INTEGRATED RESOURCE PLAN
Spring Creek Division - Pipe Replacement Year 3 SIR Impact
Customer Usage and Counts
Appendix L-2.SC.4.3

	<u>Customers</u>	<u>Annualized Consumption</u>
Cold Springs Water	3,849	450,057,365
Spanish Springs Water	582	171,565,573
Spring Creek Water	5,066	760,377,111
Pahrump Water	6,474	919,066,906
Pahrump Water x Irrigation Transimission	6,439	781,517,308
Pahrump Sewer	4,575	
Spring Creek Sewer	149	

Source: May 31, 2023 Usage and Customer Counts

GBWC 2024 INTEGRATED RESOURCE PLAN
Spring Creek Division - Rehab Tract 200 High Tank SIR Impact
Future Value Revenue Requirement
Appendix L-2.SC.5.1

		<u>Tank</u>	<u>Ref</u>	<u>Calc</u>
Plant in Service	\$	682,106	A	
Useful Life (Years)		<u>50</u>	B	
Depr Expense	\$	<u>13,642</u>	C	A/B

From Cert Filing of Docket 21-12025		
Debt	Equity	ROR
2.359%	4.768%	7.127%
Ref	D	E

			<u>Ref</u>	<u>Calc</u>
Debt Portion of RR	\$	16,091	F	A*D
Equity Portion of RR	\$	32,523	G	A*E
Gross up for Federal Income Tax	\$	<u>8,645</u>	H	G / (1-0.21) - G
RR Less Depreciation & Mill Tax	\$	57,259	I	F+G+H
Depreciation	\$	13,642	B	
Mill Tax	\$	<u>272</u>	J	(I+B)*0.00303/(1-0.21)
First Year RR	\$	<u>71,173</u>	K	I+B+J

GBWC 2024 INTEGRATED RESOURCE PLAN
Spring Creek Division - Rehab Tract 200 High Tank SIR Impact
System Improvement Rate - Rate Design
Appendix L-2.SC.5.2

Total SIR Revenue Requirement	\$	71,173	From Revenue Requirement
--------------------------------------	-----------	---------------	--------------------------

Expected 12 Month Consumption (gallons)		760,377,111	Based on consumption and customer count as of May 2023
--	--	--------------------	--

Rate Design*

Customer Class	\$	Rate per 1,000 gallons
Residential	\$	0.09
Multi-Res	\$	0.09
Non-Residential	\$	0.09
Irrigation	\$	0.09

***Calculation References**

Revenue requirement divided by (Total Annualized Consumption / 1,000)

GBWC 2024 INTEGRATED RESOURCE PLAN
Spring Creek Division - Rehab Tract 200 High Tank SIR Impact
Customer Usage and Counts
Appendix L-2.SC.5.3

	<u>Customers</u>	<u>Annualized Consumption</u>
Cold Springs Water	3,849	450,057,365
Spanish Springs Water	582	171,565,573
Spring Creek Water	5,066	760,377,111
Pahrump Water	6,474	919,066,906
Pahrump Water x Irrigation Transimission	6,439	781,517,308
Pahrump Sewer	4,575	
Spring Creek Sewer	149	

Source: May 31, 2023 Usage and Customer Counts

GBWC 2024 INTEGRATED RESOURCE PLAN
 Spring Creek Division - WWTP Reconditioning SIR Impact
 Future Value Revenue Requirement
 Appendix L-2.SC.6.1

	<u>Tank</u>	<u>Ref</u>	<u>Calc</u>
Plant in Service	\$ 670,244	A	
Useful Life (Years)	<u>28</u>	B	
Depr Expense	<u>\$ 23,937</u>	C	A/B

From Cert Filing of Docket 21-12025		
	Debt	Equity
	2.359%	4.768%
ROR		7.127%
Ref	D	E

	<u>Ref</u>	<u>Calc</u>
Debt Portion of RR \$	15,811	F A*D
Equity Portion of RR \$	31,957	G A*E
Gross up for Federal Income Tax \$	8,495	H $G / (1-0.21) - G$
RR Less Depreciation & Mill Tax \$	56,263	I F+G+H
Depreciation \$	23,937	B
Mill Tax \$	308	J $(I+B)*0.00303/(1-0.21)$
First Year RR \$	80,508	K I+B+J

GBWC 2024 INTEGRATED RESOURCE PLAN
Spring Creek Division - WWTP Reconditioning SIR Impact
System Improvement Rate - Rate Design
Appendix L-2.SC.6.2

Total SIR Revenue Requirement	\$	80,508	From Revenue Requirement
--------------------------------------	-----------	---------------	--------------------------

Rate Design*

<u>Customer Class</u>	<u>Meter Size</u>	<u>Annual Rev Requirem</u>	<u>Rate/Customer/Month</u>
Residential	All	\$21,212.95	\$21.04
Multi-Family	3/4"	\$3,909.24	\$36.20
Multi-Family	1"	\$18,308.80	\$61.03
Multi-Family	1.5"	\$10,909.52	\$101.01
Multi-Family	2"	\$6,060.84	\$168.36
Non-Residential	3/4"	\$2,606.16	\$36.20
Non-Residential	1"	\$3,661.76	\$61.03
Non-Residential	1.5"	\$7,273.01	\$101.01
Non-Residential	2"	\$2,020.28	\$168.36
Non-Residential	3"	\$4,545.63	\$378.80

GBWC 2024 INTEGRATED RESOURCE PLAN
Spring Creek Division - WWTP Reconditioning SIR Impact
Revenue Allocation
Appendix L-2.SC.6.3

	Service Agreement	Meter Size	Customer Count	Current Rate	Annual Rev	Alloc. %
Residential	Residential	All	84	\$ 50.00	\$ 50,400	26.35%
Multi-Family3/4"	Multi-Family	3/4"	9	\$ 86.00	\$ 9,288	4.86%
Multi-Family1"	Multi-Family	1"	25	\$ 145.00	\$ 43,500	22.74%
Multi-Family1.5"	Multi-Family	1.5"	9	\$ 240.00	\$ 25,920	13.55%
Multi-Family2"	Multi-Family	2"	3	\$ 400.00	\$ 14,400	7.53%
Non-Residential3/4"	Non-Residential	3/4"	6	\$ 86.00	\$ 6,192	3.24%
Non-Residential1"	Non-Residential	1"	5	\$ 145.00	\$ 8,700	4.55%
Non-Residential1.5"	Non-Residential	1.5"	6	\$ 240.00	\$ 17,280	9.03%
Non-Residential2"	Non-Residential	2"	1	\$ 400.00	\$ 4,800	2.51%
Non-Residential3"	Non-Residential	3"	1	\$ 900.00	\$ 10,800	5.65%
			149		\$ 191,280	100.00%

Source: Company records as of May 31, 2023.

GBWC 2024 INTEGRATED RESOURCE PLAN
 Spring Creek Division - Booster Pump Tract 200 SIR Impact
 Future Value Revenue Requirement
 Appendix L-2.SC.7.1

		<u>Tank</u>	<u>Ref</u>	<u>Calc</u>
Plant in Service	\$	690,109	A	
Useful Life (Years)		<u>25</u>	B	
Depr Expense	\$	<u>27,604</u>	C	A/B

From Cert Filing of Docket 21-12025		
Debt	Equity	ROR
2.359%	4.768%	7.127%
Ref	D	E

			<u>Ref</u>	<u>Calc</u>
Debt Portion of RR	\$	16,280	F	A*D
Equity Portion of RR	\$	32,904	G	A*E
Gross up for Federal Income Tax	\$	8,747	H	G / (1-0.21) - G
RR Less Depreciation & Mill Tax	\$	<u>57,931</u>	I	F+G+H
Depreciation	\$	27,604	B	
Mill Tax	\$	<u>328</u>	J	(I+B)*0.00303/(1-0.21)
First Year RR	\$	<u>85,863</u>	K	I+B+J

GBWC 2024 INTEGRATED RESOURCE PLAN
Spring Creek Division - Booster Pump Tract 200 SIR Imp
System Improvement Rate - Rate Design
Appendix L-2.SC.7.2

<u>Total SIR Revenue Requirement</u>	<u>\$</u>	<u>85,863</u>	From Revenue Requiremen
--------------------------------------	-----------	---------------	-------------------------

<u>Expected 12 Month Consumption (gallons)</u>		<u>760,377,111</u>	Based on consumption and
--	--	--------------------	--------------------------

Rate Design*

<u>Customer Class</u>	<u>Rate per 1,000 gallons</u>
Residential	\$ 0.11
Multi-Res	\$ 0.11
Non-Residential	\$ 0.11
Irrigation	\$ 0.11

*Calculation References

Revenue requirement divided by (Total Annualized Consumption / 1,000)

oact

it

l customer count as of December 2023

GBWC 2024 INTEGRATED RESO
Spring Creek Division - Booster Pump Ti
Customer Usage and Co
Appendix L-2.SC.7.3

	<u>Customers</u>	<u>Annualized Consumption</u>
Cold Springs Water	3,849	450,057,365
Spanish Springs Water	582	171,565,573
Spring Creek Water	5,066	760,377,111
Pahrump Water	6,474	919,066,906
Pahrump Water x Irrigation Transimission	6,439	781,517,308
Pahrump Sewer	4,575	
Spring Creek Sewer	149	

Source: May 31, 2023 Usage and Customer Counts

SOURCE PLAN
tract 200 SIR Impact
units

GBWC 2024 INTEGRATED RESOURCE PLAN
 Spring Creek Division - Replace Tract 200 High Tank SIR Impact
 Future Value Revenue Requirement
 Appendix L-2.SC.8.1

		<u>Tank</u>	<u>Ref</u>	<u>Calc</u>
Plant in Service	\$	1,217,010	A	
Useful Life (Years)		<u>50</u>	B	
Depr Expense	\$	<u>24,340</u>	C	A/B

From Cert Filing of Docket 21-12025		
Debt	Equity	ROR
2.359%	4.768%	7.127%
Ref	D	E

			<u>Ref</u>	<u>Calc</u>
Debt Portion of RR	\$	28,709	F	A*D
Equity Portion of RR	\$	58,027	G	A*E
Gross up for Federal Income Tax	\$	<u>15,425</u>	H	G / (1-0.21) - G
RR Less Depreciation & Mill Tax	\$	102,161	I	F+G+H
Depreciation	\$	24,340	B	
Mill Tax	\$	<u>485</u>	J	(I+B)*0.00303/(1-0.21)
First Year RR	\$	<u>126,987</u>	K	I+B+J

GBWC 2024 INTEGRATED RESOURCE PLAN
 Spring Creek Division - Replace Tract 200 High Tank SIR Impact
 System Improvement Rate - Rate Design
 Appendix L-2.SC.8.2

<u>Total SIR Revenue Requirement</u>	\$	126,987	From Revenue Requirement
--------------------------------------	----	---------	--------------------------

<u>Expected 12 Month Consumption (gallons)</u>	760,377,111	Based on consumption and customer count as of December 2023
--	-------------	---

Rate Design*

<u>Customer Class</u>	<u>Rate per 1,000 gallons</u>
Residential	\$ 0.17
Multi-Res	\$ 0.17
Non-Residential	\$ 0.17
Irrigation	\$ 0.17

*Calculation References

Revenue requirement divided by (Total Annualized Consumption / 1,000)

GBWC 2024 INTEGRATED RESO
Spring Creek Division - Replace Tract 200
Customer Usage and Co
Appendix L-2.SC.8.3

	<u>Customers</u>	<u>Annualized Consumption</u>
Cold Springs Water	3,849	450,057,365
Spanish Springs Water	582	171,565,573
Spring Creek Water	5,066	760,377,111
Pahrump Water	6,474	919,066,906
Pahrump Water x Irrigation Transimission	6,439	781,517,308
Pahrump Sewer	4,575	
Spring Creek Sewer	149	

Source: May 31, 2023 Usage and Customer Counts

OURCE PLAN
High Tank SIR Impact
units

APPENDIX M

Miscellaneous Data

Great Basin Water Company – All Divisions

Miscellaneous Data

AWWA Key Performance Indicators for Non-Revenue Water

Key Performance Indicators for Non-Revenue Water

AWWA Water Loss Control Committee Report

November 2019

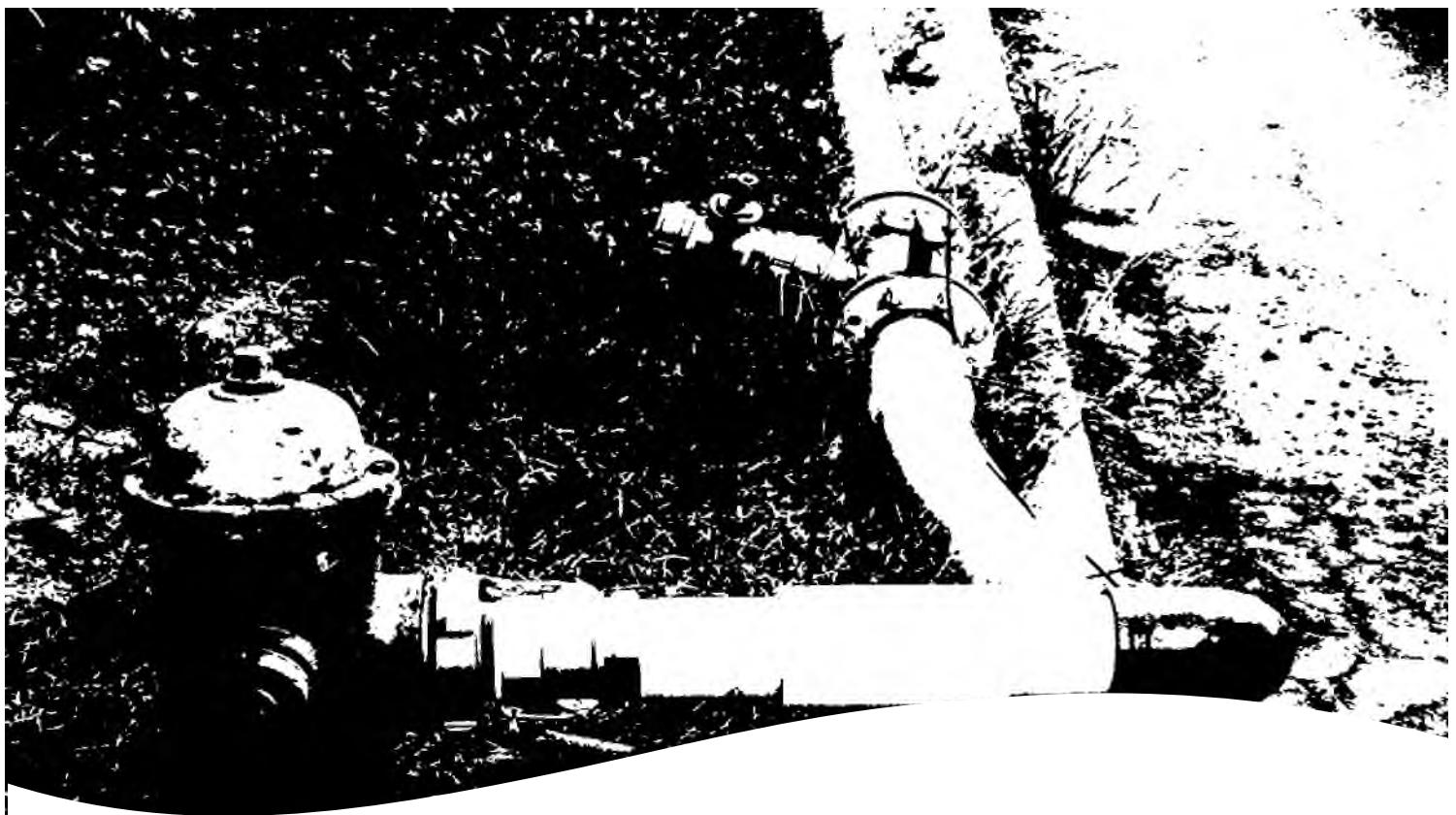

**American Water Works
Association**

Dedicated to the World's Most Important Resource®

Key Performance Indicators for Non-Revenue Water

Prepared by the AWWA
Technical and Education
Council's Water
Loss Control Committee

November 2019

Principal Authors

Will Jernigan, Cavanaugh & Associates
George Kunkel, Kunkel Water Efficiency Consulting
Gary Trachtman, Arcadis, U.S., Inc.
Alan Wyatt, Water Supply Management Consultant

AWWA Performance Indicator Task Force

Steve Cavanaugh, Cavanaugh & Associates
Andrew Chastain-Howley, Atonix Digital
Steve Davis, Metering Technology Consultants
Kevin Hickerson, Consolidated Utility District, TN
Maureen Hodgins, Water Research Foundation
Will Jernigan, Cavanaugh & Associates
George Kunkel, Kunkel Water Efficiency Consulting
Chris Leauber, Water & Wastewater Authority of Wilson County
Mathieu Laneuville, Quebec Ministry of Municipal Affairs and Housing
Bruce Macler, U.S. EPA Region 9
Sofia Marcus, Los Angeles Department of Water and Power
David Sayers, Black & Veatch
Brian Skeens, Jacobs
Jim Siriano, AWWA
Dan Strub, City of Austin, Austin Water
Reinhard Sturm, Water Systems Optimization, Inc.
Gary Trachtman, Arcadis, U.S., Inc.

Copyright ©2019 American Water Works Association.

The American Water Works Association is the largest nonprofit, scientific and educational association dedicated to managing and treating water, the world's most important resource. With approximately 51,000 members, AWWA provides solutions to improve public health, protect the environment, strengthen the economy and enhance our quality of life.

This publication is a Technical and Education Council (TEC) Water Loss Control Committee Report. An AWWA Committee Report is a statement of findings made by a committee to the President, or Chair of the Committee, Council, or Division by which its formation was authorized. The reports are subject to approval by the Council under which they are developed and the Executive Committee should it choose to review them, or by the Board of Directors (if developed under the Board).

The authors, contributors, editors, and publisher do not assume responsibility for the validity of the content or any consequences of their use. In no event will AWWA be liable for the direct, indirect, special, incidental, or consequential damages arising out of the use of the information presented in this publication. In particular, AWWA will not be responsible for any costs, including, but not limited to, those incurred as a result of lost revenue.

American Water Works Association
6666 West Quincy Avenue
Denver, CO 80235-3098
303.794.7711

www.awwa.org

© Copyright 2019 American Water Works Association | iii



List of Abbreviations

AWWA – American Water Works Association
CRUC – Customer Retail Unit Charge
DVS – Data Validity Score
DVT – Data Validity Tier
FA – Frontier Analysis
FPPI – Financial Percentage Performance Indicator
FWAS - AWWA Free Water Audit Software
KPI – Key Performance Indicator
LCR – Loss Cost Rate
NRW – Non-revenue Water
NWL – Normalized Water Losses
PITF – Performance Indicator Task Force
TEC – Technical and Educational Council
UFW – Unaccounted-for Water
VPC - Variable Production Cost
VPPI – Volumetric Percentage Performance Indicator
WLCC – Water Loss Control Committee

1. Background

Since 2003, AWWA's Water Loss Control Committee (WLCC) has encouraged utilities and other stakeholders to use the non-revenue water (NRW) key performance indicators (KPIs) in *M36 Water Audits and Loss Control Programs* and the associated Free Water Audit Software to help assess and control water losses. Based on potential new indicators and concern about the use of percentage indicators, however, the WLCC formed and directed a Performance Indicators Task Force (PITF) to draft a Committee Report that:

- ◆ recommends a new set of NRW KPIs; and
- ◆ provides guidance to utilities and other stakeholders on how best to interpret and use the KPIs.

The Committee Report (see below) was approved by the WLCC and includes three primary changes to the NRW performance indicators. The changes were based in part on the results from the Committee's 2018 TEC Project - *Assessment of Performance Indicators for Non-Revenue Water Target Setting and Progress Tracking*.

2. Introduction

Drinking water utilities are challenged by deteriorating infrastructure, growing customer expectations, new regulatory requirements, and a changing climate. Recognizing that “what gets measured gets managed”, water utilities rely on performance indicators that are “actionable” to drive improvements in their operations.

Water loss control includes efforts that water utilities employ to minimize NRW, which is comprised of real (physical) losses, largely leakage, apparent (non-physical) losses that result in customer under-billing, and unbilled authorized consumption. The American Water Works Association (AWWA) recommends that water utilities employ a best practice water audit method embodied in Manual of Practice M36 – *Water Audits and Loss Control Programs* (4th ed., 2016)¹. AWWA also provides a free spreadsheet software tool to apply this method - the AWWA Free Water Audit Software (FWAS) (version 5.0, 2014)² and forthcoming version 6.0 (2020). AWWA also supports the use of annual water audits by water utilities in its Metering and Accountability Policy Statement (<https://www.awwa.org/Policy-Advocacy/AWWA-Policy-Statements/Metering-and-Accountability>). These tools and policies guide water utilities in quantifying water losses, evaluating cost-effective loss control actions, and demonstrating to regulators, customers, and other stakeholders that they are responsible stewards of the valuable water resources and money that they manage.

Thousands of water utilities have used AWWA tools to compile a reliable water audit and implement effective loss control practices, and this approach is now required practice in several US states and at least one Canadian province. A large body of reliable water audit data has been collected from water utilities, and analysis of the data provides evidence of the types, extent, and costs of losses occurring in North American.

The traditional use of a single NRW percentage loss indicator or “unaccounted-for” water percentage – which is imprecise – continues to bring more confusion than coherence to water loss assessments. This method, arguably, has never been successful in motivating sustained, measurable loss reductions. The AWWA water audit method includes an array of key performance indicators (KPIs) that represent both traditional and new, more insightful ways to evaluate NRW. While the current FWAS includes effective KPIs, it also still employs two percentage indicators, although this is now considered to be a weakness by AWWA’s WLCC.

With the development of version 6.0 of the FWAS, the WLCC determined that it was time to reevaluate its position on NRW KPIs. The WLCC believed that new KPIs are superior to percentages for water loss management and, in 2015, launched the Performance Indicators Task Force (PITF) to evaluate the acceptability of historically used KPIs and recommend the appropriate set of NRW KPIs to employ going forward, i.e. the **2020 Position**.

The PITF included WLCC leadership and members from a broad spectrum of water industry professionals and affiliations. The PITF conducted research and evaluated traditional and contemporary NRW KPIs, which served as the basis of the 2020 position. The newly recommended slate of KPIs will appear in version 6.0 of the FWAS upon its release in 2020, the 2020 AWWA Benchmarking Survey, and the next edition of M36.

The decisions formulated by the PITF in guiding the new WLCC position include recommendations to:

- ◆ discontinue support for any percentage performance indicator; including the volumetric percentage performance indicator (VPPI), often expressed as an “unaccounted-for” water percentage, the financial percentage performance indicator (FPPI), and others structured as a percentage.
- ◆ promote certain existing and two new KPIs; the *Loss Cost Rate* and *Normalized Water Losses*, to use specifically in place of percentage indicators, and
- ◆ guide water utilities, regulatory agencies, and other stakeholders in employing and interpreting NRW KPIs in a manner that meets their situational needs.

The process leading to these recommendations is described in this report along with general guidance for implementing them. The WLCC’s 2020 position is believed to be the important next step in the evolution of water loss control advancement for the North American drinking water industry.

3. The Evolution of NRW Performance Indicators

NRW assessments in North America date from the 1950’s (**see sidebar**), but the “AWWA water audit method” dates from the 2003 AWWA WLCC Report. In this report, the WLCC recommended that the water industry not employ the “unaccounted-for water” (UFW) term or express losses as UFW%. Additionally, AWWA recommended against setting loss reduction goals around a specific target such as “less than 10%”, recognizing that loss reduction targets are best tailored as system-specific goals for each water utility rather than a “one size fits all” approach.

While recommending against the use of percentage indicators, AWWA still retained VPPI and FPPI in its guidance materials and tools because some industry stakeholders believed that volumetric percentages are easy to understand. In 2015, the WLCC improved its messaging to the water community by stressing that water utilities should assess their NRW in terms of **the three V's**:

- ◆ **Volume** – of annual losses: apparent and real
- ◆ **Value** – of annual losses: uncaptured revenue from apparent losses and (typically) excessive production costs from real (leakage) losses
- ◆ **Validity** – water audit data quality, as represented by the Data Validity Score (DVS), a rating of data quality included in the FWAS.

Note that version 6.0 of the FWAS, to be released in 2020, will feature *Data Validity Tiers (DVT)*, which are band-type groupings of DVSs (e.g., Tier I: DVS=0-25; Tier II: DVS=26-50). The tiers will provide a broad indicator of audit reliability, with DVS measuring incremental changes towards a higher or lower tier. DVS should not be used as a quantitative indication of accuracy for the audit outputs.

Key Performance Indicators for Non-revenue Water Management in North America: a timeline

- ◆ **1957: AWWA Committee Report *Revenue-producing vs. Unaccounted-for Water*³ results in many North American regulatory agencies adopting percentage indicators for NRW assessments.**
- ◆ **2000: International Water Association and AWWA undertook research and published a best practice water audit method⁴ defining real and apparent losses and serving as the basis for the AWWA water audit method.**
- ◆ **2001: Beecher Policy Research published *Survey of State Agency Water Loss Reporting Practices*⁵, noting that a “better system of accounting is the foundation for a better system of accountability for the drinking water supply industry”.**
- ◆ **2003: Water Loss Control Committee Report *Applying Worldwide Best Management Practice Water Loss Control*⁶ defines the AWWA water audit method.**
- ◆ **2006: the AWWA Free Water Audit Software is released for public use. Current Version 5.0 released in 2014. Version 6.0 to be released in 2020.**
- ◆ **2009: AWWA’s 3rd edition guidance manual M36, *Water Audits and Loss Control Programs*, published terminology of 2003 Committee Report included. Current 4th Edition published in 2016.**

Although AWWA recommends that the industry stop using percentage indicators, the current versions of M36 and the FWAS include VPPI and FPPI. Thus, there is still confusion as evidenced by:

- ◆ Inquiries received by AWWA from the regulatory community and other stakeholders seeking the “acceptable” water loss percentage level.
- ◆ Publications on water loss that refer to the “AWWA Standard of ___%” - the “standard” listed as anything from 5% to 20%. These misrepresentations, often derived anecdotally, come from technology and service providers, regulatory agencies, environmental groups, and water utilities. Since 2003, AWWA has recommended that it is best for utilities to set system-specific loss targets, and not use a prescribed one-size-fits-all number.

These occurrences run counter to AWWA’s messaging that water utilities should use the three V’s when conducting water loss assessments. **VPPI and FPPI will be removed from the next versions of M36 and the FWAS.**

Many water utilities use the AWWA water audit method – the FWAS has been downloaded more than 12,000 times since its initial release in 2006. And many North American regulatory agencies have adopted the AWWA water audit method and require annual water audit data collection in this format. Leading examples include Georgia, California, and Quebec, CA which have implemented comprehensive water audit programs with formal training, structured audit data collection, and data validation that are helping to advance water utility knowledge and practice, as well as reducing water losses.

4. The Process Used by the Performance Indicator Task Force

The PITF set forth criteria for the suite of NRW KPIs advocated in the 2020 position and recommended they should be:

- ◆ technically rigorous, reflecting field observations and theoretical principles, without significant bias or influence from situational parameters;
- ◆ easily understood by a wide range of stakeholders, including water utilities, regulatory agencies, customers, elected officials, and the media;
- ◆ suitable for target-setting and progress monitoring of loss reduction activities, i.e., they must be actionable; and
- ◆ suitable for the state of readiness of North American water utilities and regulatory agencies, recognizing that many water utilities will be new to water loss control and that regulatory agencies need ways to collect water audit data and monitor loss control that can be readily implemented.

It is important to note that no KPI in the recommended suite is expected to satisfy all four of these criteria. However, they are all technically rigorous and suitable for the state of readiness of North American water utilities and regulatory agencies. Some KPIs are specifically suited for setting loss reduction targets, while others are fit for benchmarking, assessing operation and/or financial efficiency, etc. Certain KPIs are expected to resonate well with non-technical stakeholders, while others have strong appeal for regulatory agencies. Most importantly, the AWWA water audit method features a full array of KPIs that, when applied collectively, provide a fuller understanding of the occurrence of NRW and its costs in utility operations than previously available. Loss control

activities are reliably planned and conducted when using the full suite of NRW KPIs in the AWWA water audit method. This is significant because NRW management has been historically hindered by the longstanding misconception that NRW assessments can be reliably conducted using only a single KPI (percentage or otherwise).

The PITF knew the KPIs needed to be both technically astute and understood by general stakeholders. And they began with an understanding that percentage indicators are technically weak because they are distorted by changing customer consumption levels, and thus easily misunderstood. Additionally, percentages are not actionable. Setting and achieving goals involving lower percentages does not necessarily translate into saving water, reducing production costs, or gaining revenue. Certain NRW KPIs must be actionable or able to be used for translating loss reduction efforts to measurable savings in water and money. In moving beyond percentage indicators, the drinking water industry will also move beyond the misconception that a utility's loss standing can be assessed using any single KPI. Complex assessments, from financial performance to drinking water quality, typically rely on multiple parameters and KPIs to give a full and objective assessment of utility standing.

NRW KPIs must be applicable to the current state of readiness of water utilities and North American regulatory agencies to implement. While AWWA methods and tools have been embraced by many water utilities, they are still new to others. Thus, KPIs and their implementation must be readily grasped by water utilities of all sizes, albeit with moderate training to understand the methods.

The features of the 2020 position will be included in Version (6.0) of the FWAS (targeted for 2020) and the next edition (5th) of the AWWA M36 publication (targeted for 2021). Incorporating the 2020 position into AWWA's key water loss control publications will support the drinking water industry over the next five years or so, but additional improvements in the water audit process and data collection software platforms are already being planned. Over time the WLCC will consider further NRW KPIs advancements, based on the assumption that the drinking water industry will be more familiar with water loss control fundamentals and ready to advance to a higher level of performance assessment. The Committee expects that the volume and sophistication of NRW related data will increase greatly and that new platforms for North America-wide water efficiency data collection and analysis will be needed.

5. AWWA-funded Research on NRW Performance Indicators

Current and new NRW KPIs were examined using the PITF's four-part criterion as described in the Technical and Education Council's (TEC) report *Assessment of Performance Indicators for Nonrevenue Water Target Setting and Progress Tracking (2019)*⁷. The tasks conducted for this report included:

- ◆ Providing a list of NRW KPIs to evaluate and control NRW, including those that are suited for setting water loss control targets.
- ◆ Analyzing prospective KPIs using validated water audit data, including data from California⁸ and Georgia⁸ and an enhanced version of the AWWA Water Audit Data Initiative (WADI) known as the WADI Plus dataset⁸.

- ◆ Surveying several US state and Canadian provincial regulatory entities that have implemented water loss control regulations and that document the key characteristics of their programs, including how they use NRW KPIs.

The core methodology of the research assessed each indicator for the four-criteria using a mix of quantitative and qualitative scoring. Technical rigor was assessed using the Frontier Analysis (FA) method which predicts relative performance for utilities in a similar mathematical situation. If an indicator measuring real losses, for example, is well correlated with real loss performance from the Frontier Analysis, then that indicator was considered technically rigorous.

The final TEC Project report presented a recommended set of NRW KPIs, and a rationale for phasing in or out certain indicators. The research provided objective assessments of NRW KPIs and provided the foundation of the WLCC's new position.

6. AWWA's 2020 Position on Non-revenue Water Key Performance Indicators

Since 2003, AWWA has advocated using the NRW KPIs included in the M36 publication and FWAS for water loss assessments and loss control planning. Informed by the TEC report and its member deliberations, the PITF recommended a new position on NRW KPIs along with specific guidance on their use. Three primary changes to the KPIs were recommended as follows:

1. **AWWA no longer supports any form of NRW percentage indicators**, including volumetric indicators such as water loss percentage indicators, "unaccounted-for" water percentages and financial percentage indicators.
2. **AWWA supports the use of the *Loss Cost Rate* indicator**, a new KPI expressed in value /service connection/year, with one expression for apparent losses and one for real (leakage) losses. These KPIs measure the negative impact of losses to a utility's finances.
3. **AWWA supports the use of the *Normalized Water Losses* indicator**, a new KPI expressed in volume/service connection/day. *Water losses* is the sum of apparent losses and real losses. It is meant to be employed only as a high-level indicator and in tandem with the disaggregated normalized KPIs: Normalized Apparent Loss (volume/service connection/day) and Normalized Real Loss (volume/service connection/day).

Each of these areas is discussed further in the following sections.

AWWA has discontinued support of NRW percentage indicators: Percentages are problematic because their fractional components (numerator and denominator) can be unduly influenced by factors unrelated to water loss control activities. The basis for discontinuing support for them is given below:

1. *Volumetric Percentage Performance Indicator (VPPI)*: Often expressed as the "unaccounted-for" water percentage (UFW%), this indicator is a misleading and unreliable measure of utility performance because:
 - i. VPPI is greatly affected by changing levels of customer consumption

- ii. VPPI cannot distinguish the components of non-revenue water (apparent and real losses, and unbilled authorized consumption), and
- iii. VPPI reveals nothing about water volumes and associated monetary values – the two most important factors in assessing a utility’s water efficiency.

Additionally, percentage indicators like VPPI are not technically rigorous because they can be significantly influenced by parameters unrelated to NRW.

AWWA recommends that water utilities, regulatory agencies and other industry stakeholders discontinue use of a VPPI or “unaccounted-for” water percentage indicator.

- 2. *Financial Percentage Performance Indicator (FPPI)*: This indicator also has limitations due to similar undue influences on the numerator and denominator, particularly the wide annual variation in total operating costs (denominator) that has been observed across water utilities⁷. Also, the apparent loss cost – a component of the FPPI – is set by the Customer Retail Unit Charge (CRUC), which can also vary widely for several reasons (e.g., some water utilities include sewer charges in the CRUC).

This KPI has been employed formally in a regulatory context in a single US State (the only such use of this KPI known to the PITF), which uses it as both a performance tracking indicator and a target-setting indicator. By removing its support for the FPPI, AWWA recognizes that an alternative financial indicator is needed, and the *Loss Cost Rate* KPI is offered for consideration by regulatory agencies because it is a superior KPI to the FPPI. AWWA firmly believes that water utilities should not employ a VPPI, FPPI or any percentage KPIs in water loss assessments.

To this end, AWWA is removing all percentage indicators from its water loss publications and tools, including the next edition (5th) of the M36 guidance manual and the next version (6.0) of the AWWA Free Water Audit Software.

AWWA encourages drinking water industry stakeholders, including water utilities, and regulatory, financial rating, and water resource planning agencies to discontinue the use of percentage indicators and adopt the KPIs recommended in this report and AWWA’s forthcoming publications and tools.

In recommending against using percentage indicators, AWWA instead recommends using the two new alternative KPIs described in the following.

1. *Loss Cost Rate (LCR)*: Expressed in \$/service connection/year, the LCR is a financial KPI, with one expression for apparent losses and one for real losses. The LCR indicates the financial impact of the respective losses to the utility and has public relations value by expressing annualized loss costs (operating cost and revenue) on a 'per connection' basis. It is derived from each corresponding normalized volumetric loss indicator expressed in volume/connection/day, by converting the volume unit to its value of loss, expressed on a yearly basis. This KPI marries the *rate* of losses (apparent or real) with the *value* of those losses, as a cost rate of losses. The LCR KPIs are calculated as shown below in US customary units:

Apparent Loss Cost Rate (ALCR) calculation:

$$\text{ALCR} = \frac{(\text{AL Normalized, gal/conn/day})(\text{Customer Retail Unit Charge, \$/kgal})(365 \text{ days/year})}{1,000 \text{ gal/kgal}}$$

Kgal = 1,000 gallons

Real Loss Cost Rate (RLCR) calculation:

$$\text{RLCR} = \frac{(\text{RL Normalized, gal/conn/day})(\text{Variable Production Cost}^*, \$/\text{mg})(365 \text{ days/year})}{1,000,000 \text{ gal/mg}}$$

mg = 1,000,000 gallons

*Real losses are valued at the Variable Production Cost (VPC) for most utilities; but some utilities value real losses at the Customer Retail Unit Charge (CRUC). An additional conversion factor of 1,000 kgal/mg is needed in the above equation when the CRUC is employed.

Utilities with a high LCR incur high losses and/or high costs. On a broad level, high LCR values give a water utility good incentive to enhance their water loss control interventions. Some positive attributes of LCR include:

- i. Strong NRW assessment value at the utility level, by revealing the impact of changing loss and cost values year-to-year.
- ii. Helps with public relations by expressing the impact of costs on a "per connection" level.
- iii. Useful for regulatory agencies when employed as an "out-of-bounds" KPI to flag utilities with very high values. However, it is not appropriate to employ the LCR to set optimally low loss targets in water utilities.

PITF members have piloted and analyzed the LCR in several efforts including the 2018 TEC Project and independent work on water audit data from Pennsylvania and New Jersey^{9,10}. Water Research Foundation Project 4695 includes a downloadable spreadsheet of LCR values from North America in the form of percentiles for the range of values across utilities¹⁰. While LCR is a new KPI, it should further help water utilities and other stakeholders assess and manage water loss.

While the LCR has many strengths, it is a high-level KPI and stakeholders are advised not to employ the LCR as a singular KPI for water loss assessments. Because it is influenced by the volume of losses and their monetary value, the LCR could change notably due to a significant change in a single component. For instance, an annual reduction in loss volumes (apparent or real) may be masked by a large monetary increase that year, either due to a large water rate increase (CRUC) or increase in the Variable Production Cost (VPC). In this way the LCR is not directly actionable as a target setting or benchmarking KPI. It is appropriate to assess the LCR in combination with the other KPIs in the AWWA water audit method.

2. *Normalized Water Losses (NWL)*: Expressed in volume/connection/day, NWL is a high-level KPI that represents the combined volume of apparent and real losses occurring in the water utility, on a per connection basis. The NWL metric allows utilities to track their year-to-year losses and provides additional insight during years when either portion of NWL (apparent or real normalized loss rate) varies notably from the prior year. NWL should not be used as a “stand-alone” KPI, but in combination with the apparent and real loss normalized indicators. Also, as a high-level indicator, NWL is not actionable because its components include water that is physically lost (real losses) and water that is not physically lost but under-recorded (apparent losses). Thus, NWL should not be used for target-setting. Instead, targets can be set using the Normalized Apparent and Real Loss indicators. NWL is best used to assist the data validation process by helping to broadly explain year-to-year changes in apparent and real loss volumes and provide a buffer against inordinate uncertainty in either of these volumes.

NWL is new and has not yet been employed extensively. As a combined version of the Normalized Apparent Losses and Normalized Real Losses indicators, NWL is subject to the same influencing factors as those KPIs. AWWA believes that NWL – used for high-level trending in combination with other KPIs – adds value to water loss assessments.

KPI changes in the AWWA Free Water Audit Software (FWAS): Concurrent with the WLCC’s efforts to update its position on NRW KPIs, the WLCC Software Subcommittee worked to develop version 6.0 of the FWAS. The PITF coordinated with the Subcommittee to include the two new KPIs – Loss Cost Rate (Apparent and Real forms) and Normalized Water Losses in version 6.0 of the FWAS, which is targeted for release in 2020. Version 6.0 will also include many additional improvements that reflect performance as detailed below:

1. Version 6.0 of the FWAS will include a means to recognize and capture when a water utility includes sewer charges in calculating the CRUC, which is the basis for valuing apparent loss. The FWAS will not include the actual sewer charge nor water charge, but rather will include the composite CRUC and a binary (yes or no) indication of inclusion of sewer charges incorporated into the CRUC.

2. Version 6.0 of the FWAS will include a change in the calculation of the Normalized Real Losses KPI for low service connection density utilities. Historically, the FWAS calculates Normalized Real Losses for low density systems (i.e., those with less than 32 service connections/mile of pipeline, or less than 20 service connections/kilometer of pipeline) in variant units of volume/length of pipeline/day. Low service density systems will have Normalized Real Losses calculated as both volume/connection/day (the same as systems that are not low density) and the variant form of volume/length of pipeline/day. This will place greater attention on low service density systems, but it is recognized that further research is needed on KPIs for low density systems and for wholesale water supply systems.

The updated water audit attributes and KPIs intended for version 6.0 FWAS are presented in Table 1. Using these KPIs will help utilities increase the objectivity and effectiveness of NRW assessments.

ID	Name	Description	Data Validity Score				Data Validity Tier	Notes
			Q1	Q2	Q3	Q4		
1
2
3
4
5
6
7
8
9
10
11
12
13
14
15
16
17
18
19
20

*Data Validity Tier is a new term that will appear in Version 6.0 of the FWAS (2020 release) and is a band-type grouping of Data Validity Scores: Tier I: DVS-0-25; Tier II: DVS-26-50; Tier III: DVS-51-70; Tier IV: DVS-71-90; Tier V: DVS-91-100

7. Guidance for NRW KPI Implementation

Since the launch of the FWAS in 2006, Georgia, California, Hawaii, and the province of Quebec, CA have adopted requirements for utilities to use the AWWA water audit method and the FWAS as the data collection tool. These initiatives have formal programs that offer training for water utilities in the water audit process, including data collection, validation, and analysis. The data quality of these programs is distinctly higher than programs that accept self-reported data from water utilities. ***It is strongly urged that regulatory agencies requiring water audit data collection use the AWWA FWAS, provide training for utility auditors and require formal validation of the reported water audits.*** Several states have leveraged set-aside funds from their state revolving fund programs to pay for training and validation.

The FWAS is also used with lesser requirements in many other states and agencies, including Tennessee, New Mexico, Colorado, and the Delaware River Basin Commission, with pilot projects occurring in at least another six states. Data from thousands of water audits that were compiled using the FWAS is now available, and analysis of the data has provided deeper understanding of utility water efficiency than historic approaches employing only a single percentage indicator. Additional water regulatory agencies are expected to adopt requirements for the AWWA water audit method because it enables more rational assessments, improved NRW reduction tracking, and benchmarking among water utilities. With a suite of effective KPIs available in the AWWA tools, agencies can use appropriate combinations to meet their water efficiency objectives.

Water utilities, regulatory agencies, and other stakeholders using the AWWA NRW KPIs are offered specific guidance in their use, as described below:

a) Considerations for water utilities:

- i. Water audit benefits: By focusing on the three V's (volume, value, validity) the AWWA water audit method helps water utilities save water and energy resources, set equitable water rates, and improve their financial position which may gain better access to funding opportunities for capital improvements. Utilities can reliably track and benchmark their performance and strategically plan loss reduction efforts and set loss targets. Expressing losses/costs on a "per connection" basis provides effective public relations messaging, keeping customers, regulators, the media and other stakeholders informed of utility progress in NRW management.
- ii. Data quality maturation: utilities will build reliability in their processes by allowing for a period of 3-5 years for initial data collection and data quality improvement before considering loss reduction target-setting. Data validity is often low when water utilities compile their first water audit, and reasonable time is needed to improve data management and collection processes to elevate the quality of the water audit data. On a positive note, the focus on data quality often results in water utilities beginning to improve their water efficiency processes before specific water loss reduction initiatives have been implemented.
- iii. Focus on good practice: The data grading and data validation process is based on utility operational processes and good practice leads to good data. For example, many water utilities operate with water production flowmeter installations that are poorly designed, sited, installed, and maintained. Relatively few of these metering installations are reliably tested for accuracy. The water audit data grading criteria guides utilities in improving

these flowmeter installations that produce the foundational inputs to the water audit (source water withdrawals and imported/exported bulk water supplies). Similarly, testing and systematically replacing customer meters, conducting regular leak detection, auditing customer billing systems, and other functions are also important opportunities for utility practice improvement. It is important to note that the FWAS calculations are interdependent, and accurate production and customer metering data are also critical for calculating a representative annual real (leakage) loss volume, for which measured data are not required by the FWAS. If due diligence is not applied in understanding and attaining accurate production and customer metering data, the calculation of the annual real loss volume from the FWAS will not be accurate, and real loss target setting and reduction efforts may be misdirected.

b) Considerations for regulatory agencies

- i. Water audit data collection process: Agencies collecting audits are encouraged to specify that water audit reports are submitted in the standardized electronic format of the FWAS. Agencies are also encouraged to provide training for water utility staff in the auditing process and provide for formal data validation to ensure an accurate assessment of data quality. Regulatory agencies collecting audits in the functional electronic worksheets of the FWAS will find additional value by employing the AWWA Compiler Software, which allows the data from multiple AWWA water audits to be easily compiled into a single spreadsheet. This software includes built-in capabilities to produce charts, as well as having an 'export' function that allows the data to be transferred to standard spreadsheet software for user-specific analysis.
- ii. Regulatory mission: Agencies have broad missions (environmental/financial/other), and specific regional and temporal considerations (drought, floods, etc.). Environmental agencies with a mission to protect water resources may focus on leakage management and employ the Normalized Real Loss indicators (performance tracking) and Infrastructure Leakage Index (benchmarking). Financial regulators, such as public utility commissions or state fiscal officers, may focus on the Loss Cost Rates, but realize that this KPI is best employed for identifying outliers from more typical utility performance, and should not be used to set a single target for optimized loss control. Financial regulators can assess the Normalized Loss indicators when guiding water utilities toward loss reduction that can lower production costs (via leakage management) and enhance revenues (via apparent loss control).
- iii. Identify financial improvements: By tracking costs of water the AWWA water audit method enables regulatory agencies to compile data on the range of utility cost impacts. Having this data enables agencies to identify utilities with relatively low customer water rates that may be under-funding their system, and utilities with high production costs, both of which may benefit from an effective water loss control program. Other financial considerations may also exist with improved water loss control. Utilities are better motivated by water loss reduction initiatives that yield improved financial performance and water resource sustainability from reduced water withdrawals.
- iv. Loss reduction target-setting: The AWWA water audit method offers regulatory agencies improved flexibility in developing long-term water loss reduction goals for water utilities. By tracking loss volumes, costs, and data quality with effective KPIs, agencies can tailor specific requirements to achieve the goals for their jurisdiction, region, or class/size of water utilities.

A regulatory approach that aims to establish uniform loss level targets for all utilities is impractical for water loss control. Many agencies provide regulatory oversight of water quality regulations which are applied in a prescriptive manner to all water utilities. This approach is appropriate for water quality since all drinking water utilities must provide customers with water that is safe for human consumption. Conversely, water loss control is more akin to the utility process for setting rates and charges – a process specific to the unique costs, characteristics, and regional considerations of each system. Utilities have different costs of providing service and their specific rates and charges are based upon the need to recover their individual costs of operations. Each system is unique, and the ideal loss volumes to target are those known conceptually as the “economic” levels of losses, above which constitute all losses that are cost-effective for the utility to reduce or prevent.

Developing a process that establishes cost-effective, system-specific loss targets involves more analytical rigor and administrative effort than an approach that applies a single target to all water utilities. The challenge for regulators and utilities alike is the complexity of determining the value of each utility’s loss reduction potential based upon its unique cost structure. Expected cost savings should be compared to the cost of specified loss reduction technologies and practices, which may also vary from utility to utility. Ultimately, targeted loss control activities should be cost-effective for water utilities. Agencies that routinely collect and review utility cost of service data, such as state public service commissions, may be better prepared to set individualized targets. In cases of water resources scarcity, regulatory agencies could consider setting loss reduction targets at levels lower than the economic level of water utilities within the region of scarcity. Regional thresholds for performance may need to consider regional water management goals, and factor in utility economics (short-term and long-term such as deferred infrastructure development) and the regional value of water supplies.

In 2019, the California State Water Resources Control Board began moving to establish a structure for system-specific leakage reduction targets for the 400+ water utilities that fall under its requirements.¹¹ An economic model is being developed for this purpose. The analytic tools developed for this rulemaking may subsequently be useful in other jurisdictions.

If, however, an agency is not initially in a position to devise or adopt a structure for system-specific loss reduction goals, the NRW KPIs may be used to support a tiered approach to loss reduction targets as described below.

Since many water utilities likely incur loss volumes that are well above economic levels, and many of the same water utilities are new to the water audit process, regulatory agencies might constructively begin by identifying the systems with the highest losses relative to typical utility performance. The AWWA NRW KPIs are quite useful for identifying these outliers. By focusing on the utilities with high losses and/or the greatest needs, agencies can identify that group of systems with the greatest loss reduction potential and direct resources accordingly. As data quality and system performance improve over time, agencies can consider lowering the “out-of-bounds” threshold volume so that the “bar of acceptable performance” gradually defines more efficient operations. During this phase, regulators may require a showing of improved water loss performance over a specified time period, using one or more KPIs as points of reference. This approach may be tiered with greater improvement expected of utilities whose loss volumes and/or loss costs are the greatest.

Stemming from regional water resource management concerns, the Metropolitan Atlanta, GA area set specific leakage reduction targets for participating water utilities to achieve by the year 2025. (see below). This is a good example of an agency employing a tiered approach to performance requirements based on a multi-year history of validated water audit data – the State of Georgia has required annual water audit data validation since 2011.

Metropolitan North Georgia Water Planning District Water Resource Management Plan¹²

Leakage Reduction Targets (issued June 2017)

- ◆ **Water utilities with real losses greater than 60 gallons/connection/day (2013 data) must adopt a 2025 goal to reduce to less than 60 gallons/connection/day and demonstrate progress in the interim years toward meeting this goal.**
- ◆ **Water utilities with real losses between 35 and 60 gallons/connection/day (2013 data) must adopt a 2025 goal to reduce to less than 35 gallons/connection/day and demonstrate progress in the interim years toward meeting this goal**

Applies to water utilities serving at least 3,300 individuals and with customer service connection density greater than 32 connections per mile of pipeline.

If a local water provider required to adopt one of the targets reasonably believes that, after detailed financial analysis, the applicable 2025 goal exceeds its system-specific economic level of leakage, then the local water provider may request a new 2025 goal that recognizes the higher leakage target.

c) Considerations for policy makers

- i. Managing water resources: A fundamental concern for public water supply is the availability of sufficient water sources that can be treated to quality standards. Reliably tracking and managing source water withdrawals is, therefore, critical to the long-term sustainability of water supplies. Having robust NRW KPIs enables water resource planners to gauge the efficiency with which annual water withdrawals are treated and supplied to customers. When treated water is lost to leakage, this portion of the water withdrawal volume is wasted, along with energy and other resources. When water utilities employ effective leakage management, they optimize their source water withdrawals, ensuring that they only withdraw the amount of water needed to meet the legitimate customer water demands placed on the distribution system.
- ii. Apparent loss control: When water utilities successfully control apparent losses, they increase the accuracy of customer consumption data, improving the reliability of regional planning studies and securing more revenue for the utility. Very importantly, accurate consumption data helps customers to better track their water usage and provides greater incentive for them to conserve. In addition, managing apparent losses improves the equity of cost allocation amongst customers.
- iii. Setting the value/cost of water, particularly in times of water resource scarcity: What we don't properly value, we waste. In many parts of North America, water is under-valued

and underpriced, including both the cost to produce treated water and distribute water to customers. Because the AWWA water audit asks water utilities to input their Variable Production Costs (VPC) and their Customer Retail Unit Charges (CRUC), validated cost data for hundreds of North American water utilities is now available. Analysis of this data is revealing interesting trends on the range of costs across water utilities. Sturm, Gasner and Andrews (2015) noted that water utilities purchasing expensive imported bulk water tend to have lower leakage rates than self-supplied water utilities¹³ (see Figure 1). Historic water loss assessments using UFW% do not report costs, thus masking the role that cost incentives or disincentives play in motivating successful water loss control. Using the AWWA water audit method allows planners to target economic water loss control at the utility level, and effective water withdrawal management at the watershed level. Arguably, scarcity of water resources should also play a role. As resources become scarce, such as from long-term drought, the value of the resource should increase in value. It can be argued that, at a certain level of scarcity, water utilities that typically value leakage at the VPC should value leakage at the CRUC. At the significantly higher CRUC, the economic benefit of aggressive leakage management increases dramatically. Alternatively, water might be valued at the long-term indirect costs of alternative water supply source development if water resources are in great scarcity. These are a few examples of the economic benefits achievable as more water utilities move away solely from using percentages and to the AWWA water audit method.

In a like manner, it can be argued that reduction of apparent loss volumes through customer meter replacement in utilities having increasing block rate structures (large water use is priced at higher unit commodity rates) should value that loss at higher than the average customer retail water rate, consistent with increasing billed water use at the highest block charged to an individual customer.

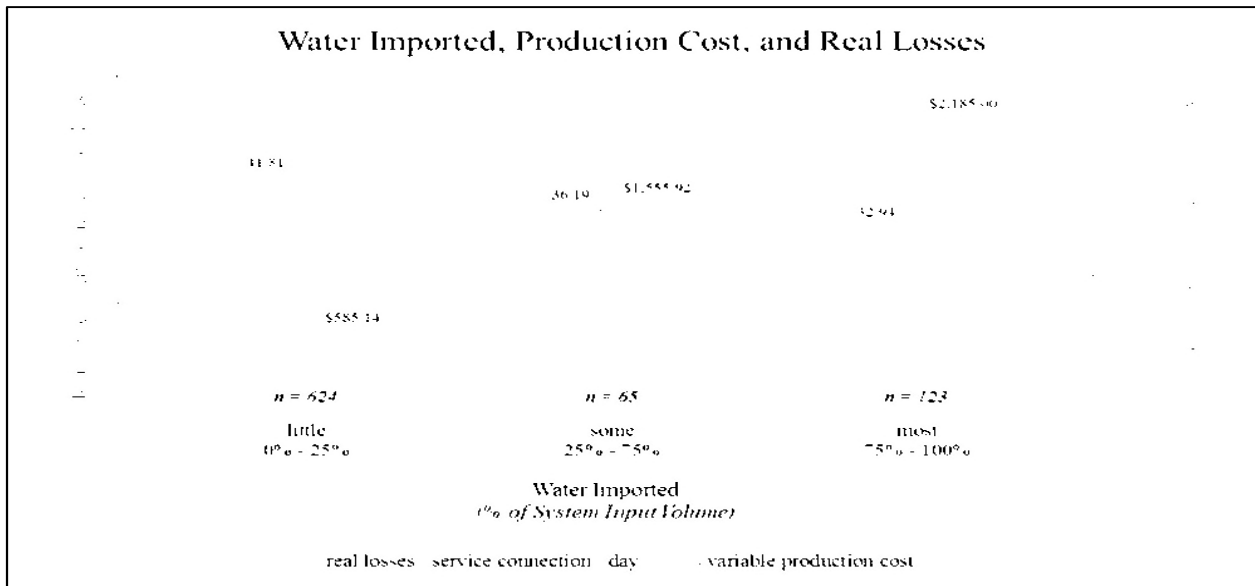

Figure 1 Incidence of real (leakage) losses in water utilities that purchase bulk imported water (data consisted of mostly self-reported water audits)

Source: Sturm et al. 2015. Reprinted with permission. © Water Research Foundation.

d) Considerations for water utility customers

- i. The AWWA water audit method offers many opportunities to improve communications with water customers compared to the historic UFW% reporting. Utilities can quote water loss reduction success in terms of volume, value, or loss rates, expressed in “per connection” units. This enables the utility to convey water loss reduction targeting and performance tracking in an effective, easy-to-understand manner. Great value can be gained by tailoring messaging to water customers, informing them of utility progress in maintaining efficient water operations and mitigating periodic stress such as that associated with droughts. This can also assist the water utility in gaining customer acceptance of water rate increases.

Table 1 describes the KPIs of the 2020 position along with their suitability for specific purposes and their limitations.

8. Benefits for the Water Industry and Water Resources

The water industry’s approaches of the past sixty years that have relied on imprecise “unaccounted-for water” percentages have not been successful in motivating measurable loss reductions. Consequently, losses have been increasing in some systems due to deteriorating infrastructure (distribution system piping and customer water meters), increasing costs, and other factors. AWWA has considerably advanced water auditing and loss control techniques over the past twenty years, and the Association believes that these newer approaches are improving water utilities’ ability to assess their water loss control standing, plan and execute effective loss reductions, and communicate this progress to industry stakeholders and customers. The improved outcomes to society include:

- ◆ **Improved management of water resources:** Establishing integrity in measuring source water withdrawals and controlling leakage protects valuable water resources, which are stressed in some regions due to periods of drought, growing populations and other factors.
- ◆ **Improved utility operations and finances:** Lost water is lost money to water utilities. In most cases, water utilities stand to benefit financially from improved water loss control practices.
- ◆ **Consistent reporting and workable planning for loss control activities.** Validated data from hundreds of US water utilities are providing detailed insight on the efficiency and cost-effectiveness of water utility operations. This data allows for astute and strategic planning around water allocations, infrastructure, and rate-setting. Water utilities now have the tools to become proactive in their water loss control efforts.
- ◆ **Better understanding of water utility performance by customers, the media, elected officials, funding agencies, and other stakeholders.** Water utilities can expect to see better acceptance from customers for water rate increases, better access to funding for capital improvements, and a better reputation and standing in their communities. Customers are also more likely to respond favorably to their conservation requirements if it is visible that the utility is also conserving water.

Multiple benefits are available to drinking water utilities via effective water loss control. More water utilities and state/provincial regulatory agencies should embrace AWWA’s water audit method.

9. Conclusions

AWWA has carefully investigated existing and new NRW key performance indicators and has recommended an updated set of KPIs for water utilities, regulatory agencies and other water industry stakeholders. Of particular note is the recommendation to discontinue support for percentage indicators which are known to be imprecise and misleading. AWWA advocates that water industry stakeholders discontinue using percentage indicators and embrace those existing and newly recommended performance indicators. This development will greatly improve the ability of drinking water utilities to identify, quantify, and value water losses and target actions to become more efficient and improve water resource management.

REFERENCES

1. AWWA (American Water Works Association). 2016. AWWA Manual of Water Supply Practices M36: Water Audits and Loss Control Programs, 4th ed. Denver, CO: AWWA.
2. AWWA (American Water Works Association). 2014. AWWA Free Water Audit Software, v5. Denver, CO: AWWA.
3. Cole, E.S., et al. 1957. Revenue Producing Water Committee Report: Revenue-producing Versus Unaccounted-for Water. Journal AWWA.
4. Alegre, H., W. Hirner, J. Baptista and R. Parena, 2000. Performance Indicators for Water Supply Services. Manual of Best Practice series. London, England: IWA Publishing.
5. Beecher, J. 2002. *Survey of State Agency Water Loss Reporting Practices*. Final Report to the Technical and Educational Council of the American Water Works Association. Indianapolis, Ind.: Beecher Policy Research, Inc.
6. Kunkel, G., et al. 2003. Water Loss Control Committee Report: Applying Worldwide Best Practices in Water Loss Control. Journal AWWA, 95(8):65.
7. AWWA (American Water Works Association). 2019. *Assessment of Performance Indicators for Nonrevenue Water Target Setting and Progress Tracking*, Denver, CO: Prepared for AWWA by Arcadis and Alan S. Wyatt.
8. Trachtman, G., J. Cooper, S. Sriboonlue, A. Wyatt, S. Davis, G. Kunkel. 2019. Guidance on Implementing an Effective Water Loss Control Plan. Project 4695. Denver, CO: Water Research Foundation.
9. *Report on the Evaluation of Water Audit Data for Pennsylvania Water Utilities*, Kunkel Water Efficiency Consulting for the Natural Resources Defense Council, 2017.
<https://www.nrdc.org/sites/default/files/pa-utilities-water-audit-data-evaluation-20170215.pdf>
10. *Report on the Evaluation of Water Audit Data for New Jersey Water Utilities*, Kunkel Water Efficiency Consulting for the Natural Resources Defense Council, 2018.
<https://www.nrdc.org/sites/default/files/nj-utilities-water-audit-data-evaluation-20170215.pdf>
11. California State Water Resources Control Board – Water Loss Control:
https://www.waterboards.ca.gov/water_issues/programs/conservation_portal/water_loss_control.html (Accessed May 25, 2019)
12. Metropolitan North Georgia Water Planning District, Water Resource Management Plan, Action Item WSWC 15, 2017, CH2M and Black and Veatch.
<https://northgeorgiawater.org/plans-manuals/>

13. Sturm, R., K. Gasner, and L. Andrews. 2015. Water Audits in the United States: A Review of Water Losses and Data Validity, Project 4372b. Denver, Colo: Water Research Foundation.



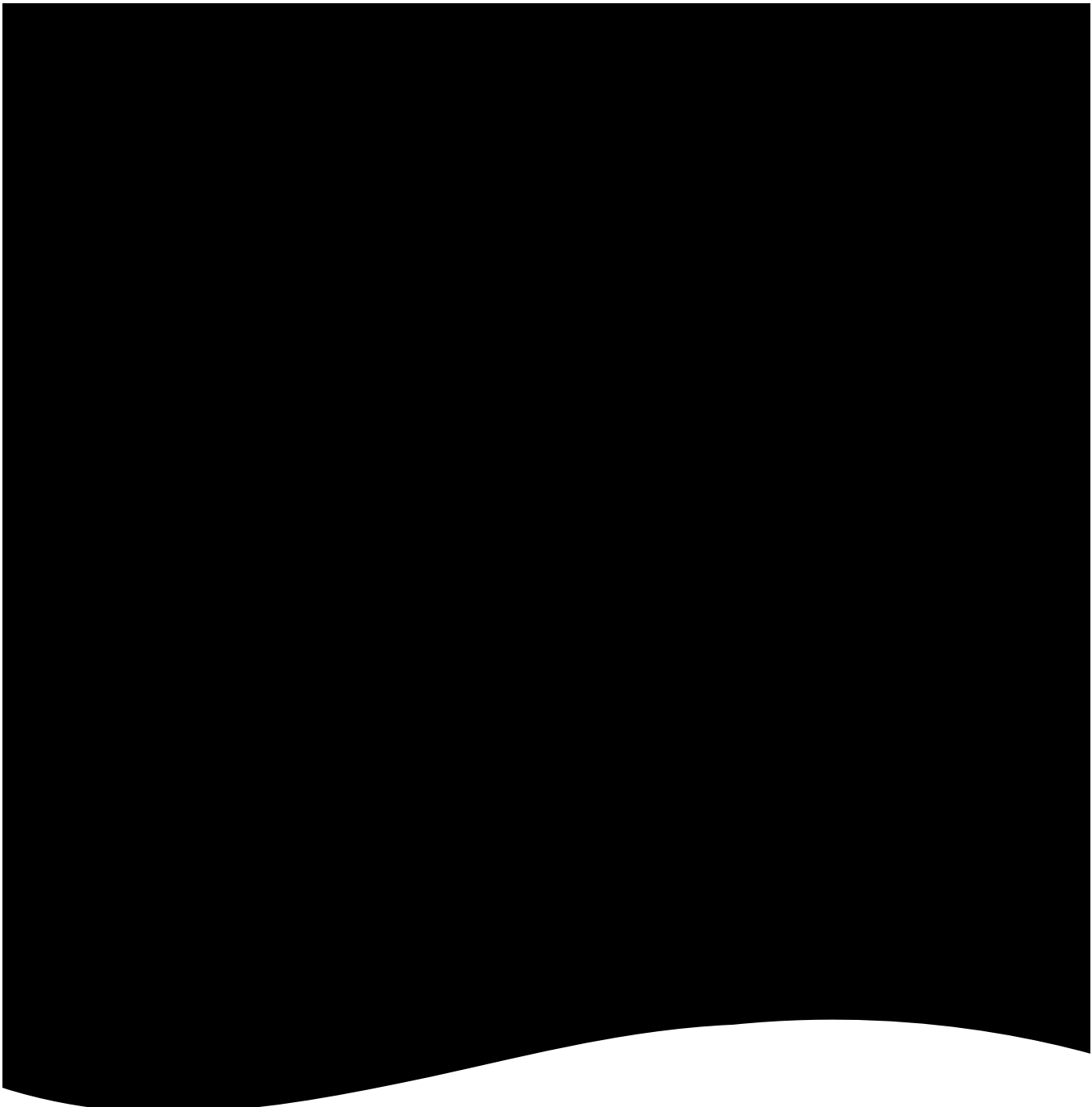

**American Water Works
Association**

Great Basin Water Company – Pahrump Division (Volume II)

Miscellaneous Data

SMMR MOU & Interim Service Agreement

SMMR Design Reports for Water & Wastewater

Limestone Gravel Pack Report

SMMR WWTP Design Report

Consolidated FOG Control Plan

SMMR MOU & Interim Service Agreement

MEMORANDUM OF UNDERSTANDING TO
THE AMENDMENT FOR WATER AND WASTEWATER SERVICE
SPRING MOUNTAIN MOTOR SPORTS RANCH
COMMERCIAL / RESIDENTIAL DEVELOPMENT
PAHRUMP, NEVADA

This *Memorandum of Understanding* (“**MOU**”) is hereby agreed upon this 2nd day of January , 2020 (“**Effective Date**”), by and between Spring Mountain Raceway, LLC, a Limited Liability Corporation (hereinafter referred to as “**Developer**”) and Great Basin Water Co., a Nevada corporation, (“**Utility**” or “**GBWC**”) (Developer and Utility are collectively referred to herein as the “**Parties**”) for the purposes for refining the mutual understanding between the parties as to the intent of the *Amendment for Water and Wastewater Service Spring Mountain Motor Sports Ranch* (the “**Amendment**”) to the *Agreement for Water and Wastewater Spring Mountain Motor Sports Ranch Commercial Residential Development, Pahrump, Nevada* (“**Agreement**”). All capitalized terms defined in the Agreement.

WHEREAS, the Parties entered into the Agreement on March 23rd, 2016 to set forth the terms of the annexation and Utility Services (and, Agreement) (as approved by the Public Utilities Commission of Nevada (“**PUCN**”), Docket No. 16-07011.

WHEREAS, the Parties entered into the Amendment to the Agreement on July 1st, 2016 for the purpose of recognizing that under Nevada Law and Policy, the Utility must set forth evidence to the PUCN that proposed revenues from an annexation must provide reasonable rates to give the Utility a reasonable opportunity to earn a fair return without burdening current customers.

WHEREAS, the Amendment set forth provisions to maintain the Utility’s ability to have a reasonable opportunity to earn a fair return without burden to current customers by establishing the parameters for establishing revenues and expenses from the Spring Mountain Motor Sports

Ranch subdivision by providing a payment from the Developer to the Utility for any deficit between revenues and expenses. Section 3 of the Amendment defines the terms and understanding of the Parties under which operations and maintenance (“O&M”) expenses will be calculated and accepted by the Parties. This MOU is to further define those terms and understanding.

NOW, THEREFORE, in consideration of the mutual covenants set forth by the Agreement, the Amendment and, hereinafter, the Parties agree as follows:

1. The Interim Service Agreement is bound to the mutual agreements and covenants in the aforementioned Agreement, Amendment and MOU.
2. As set forth in Section 3 of the Amendment, analysis of O&M costs may contain estimates or allocations.
3. All O&M costs which have a direct bill, such as but not limited to: electric, property taxes, generator maintenance, sludge hauling, will have a copy of the bill presented to the Developer at the time of invoicing.
4. All O&M costs which have a bulk delivery, such as but not limited to: chemical and generator fuel, will have a copy of the Utility’s log presented to the Developer providing the quantity delivered and price per quantity at the time of delivery.
5. All O&M costs which are deferred, such as but not limited to: odor control chemicals, inspections, will be presented to the Developer per Generally Accepted Accounting Principles (“GAAP”) rules and/or as adjusted by the PUCN, which may be retroactive as adjusted by the PUCN.
6. All O&M costs for labor will be presented to the Developer per the Developer’s Engineer’s Estimate (hours) presented and approved by the PUCN in Docket No. 16-07011 at the capitalized time rate as established annually by the Utility.

7. Any unforeseen expenses which do not fall into 1 - 5 above, will be mutually agreed upon on a case by case basis between the Parties.

IN WITNESS WHEREOF, this MOU is executed as of the Effective Date.

WITNESS:

SPRING MOUNTAIN RACEWAY LLC



By:



JOHN MORRIS,
CEO

Date:

12-26-2019

WITNESS:

GREAT BASIN WATER CO.



By:



WENDY BARNETT,
PRESIDENT

Date:

1-2-2020

INTERIM SERVICE AGREEMENT FOR
WATER AND WASTEWATER SERVICE
SPRING MOUNTAIN MOTOR SPORTS RANCH
COMMERCIAL / RESIDENTIAL DEVELOPMENT
PAHRUMP, NEVADA

This *Interim Service Agreement* is hereby agreed upon this 2nd day of January, 2020 (“**Effective Date**”), by and between Spring Mountain Raceway, LLC, a Limited Liability Corporation (hereinafter referred to as “**Developer**”) and Great Basin Water Co., a Nevada corporation, (“**Utility**” or “**GBWC**”) (Developer and Utility are collectively referred to herein as the “**Parties**”) for the purposes of defining an agreement for temporary interim water and wastewater service to Spring Mountain Motor Sports Ranch Commercial Residential Development, Pahrump, Nevada prior to full dedication of all utility facilities necessary for the Utility to provide long term water and waste water service as approved by the Public Utilities Commission of Nevada (“**PUCN**”) in Docket No. 16-07011 (“**Utility Facilities**”). All capitalized terms defined in the Agreement.

WHEREAS, the Parties entered into an Agreement for Water and Wastewater Service (“**Agreement**”) on March 23rd, 2016 to set forth the terms of the annexation and Utility Services (and, Amendment, defined below) (as approved by the “**PUCN**”, Docket No. 16-07011).

WHEREAS, the Parties entered into the Amendment to the Agreement (“**Amendment**”) on July 1st, 2016 for the purpose of recognizing that under Nevada Law and Policy, the Utility must set forth evidence to the PUCN that proposed revenues from an annexation must provide reasonable rates to give the Utility a reasonable opportunity to earn a fair return without burdening current customers.

WHEREAS, the Amendment set forth provisions to maintain the Utility’s ability to have a reasonable opportunity to earn a fair return without burden to current customers by establishing

the parameters for establishing revenues and expenses from the Spring Mountain Motor Sports Ranch subdivision by providing a payment from the Developer to the Utility for any deficit between revenues and expenses. Section 3 of the Amendment defines the terms and understanding of the Parties under which operations and maintenance (“O&M”) expenses will be calculated and accepted by the Parties.

WHEREAS, the Parties entered into a Memorandum of Understanding (“MOU”) regarding the Amendment on July 1, 2016 further defining the parameters for establishing O&M expenses from the Spring Mountain Motor Sports Ranch subdivision by providing a payment from the Developer to the Utility for any deficit between revenues and O&M expenses.

WHEREAS, the Developer has requested for the Utility to temporarily provide the operations of the water and wastewater systems prior to dedication of the Utility Facilities (anticipated to be before July 1, 2020) and the Utility agrees. This Interim Service Agreement sets forth the terms of and condition of temporary interim water and wastewater service.

NOW, THEREFORE, in consideration of the mutual covenants set forth by the Agreement, the Amendment, and MOU, hereinafter, the Parties agree as follows:

1. The Interim Service Agreement is bound to the mutual agreements and covenants in the aforementioned Agreement, Amendment and MOU.
2. The interim service is meant to be temporary and shall cease upon Utility acceptance of the Utility Facilities pursuant to PUCN approved GBWC Tariff1-W (Water) and Tariff 1-S (Sewer) dated January 12, 2017 and subsequent amendments (the “Tariffs”) or July 1, 2020 whichever is first.

3. If for some reason outside of the control of the Developer, the Utility Facilities are not accepted pursuant to the Tariffs, this Interim Service Agreement may be extended for up to sixty (60) days upon mutual agreement in writing.

IN WITNESS WHEREOF, this Interim Service Agreement is executed as of the Effective Date.

WITNESS:

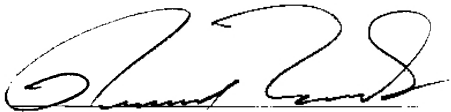

SPRING MOUNTAIN RACEWAY LLC

By:

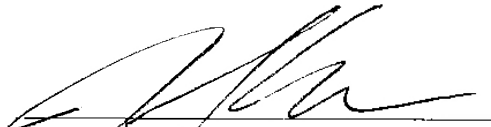
JOHN MORRIS,
CEO

Date:

12-26-2019

WITNESS:



GREAT BASIN WATER CO.

By:

WENDY BARNETT,
PRESIDENT

Date:

1-2-2020

SMMR Design Reports for Water & Wastewater

DESIGN REPORT

Water System Design

Spring Mountain Motorsports Ranch

Submitted To: Russ Meads
Double M Construction
2170 S. Cortina Ave.
Pahrump, NV 89048

Submitted By: Golder Associates Inc.
595 Double Eagle Court, Suite 1000
Reno, NV 89521 USA

Distribution: Jim Balderson, NDEP-BSDW (2 copies)
Russ Meads, Double M Construction (1 copy)
Wendy Barnett, UICN (1 copy)
Golder Associates (1 copy)

April 29, 2016

Project No.1520359



Design Report
Water System Design
Spring Mountain Motorsports Ranch
Pahrump, Nevada

The following design report has been prepared by the staff of Golder Associates Inc. under the professional supervision of the engineers whose signatures appear herein.

The findings, design, and recommendations presented in this report were presented within the limits described by Double M Construction, after being prepared in accordance with generally accepted professional engineering principles and practices.



Michael Bidart, PE
Project Manager

John Connell
Senior Consultant

Matt Barton, PE
Project Engineer

Table of Contents

1.0	INTRODUCTION.....	1
2.0	OWNER/OPERATOR	1
3.0	MASTER PLAN.....	2
4.0	AREA CHARACTERISTICS	3
4.1	Adjacent Land Use.....	3
4.2	Topography	3
4.3	Flood Plains.....	3
4.4	Soils Information	3
5.0	WATER SYSTEM DESIGN CRITERIA.....	4
5.1	Water Flow Rates.....	4
5.2	Water Supply.....	5
5.3	Water Storage	6
5.4	Water Distribution.....	6
5.5	Booster Pump Station Criteria.....	7
5.6	Water System Criteria Summary.....	7
5.7	Disinfection.....	7
6.0	WATER SYSTEM DESIGN	9
6.1	Well Pumping Facilities	9
6.1.1	Existing Well No. 1 Construction.....	9
6.1.2	Proposed Well No. 2 Construction.....	9
6.1.3	Well Pump Installation	10
6.1.4	Chlorination	10
6.2	Storage Tanks	11
6.3	Booster Pump Station	11
6.4	Booster-Tank Site Improvements.....	12
6.5	Transmission Mains	12
6.6	Water System Operation and Maintenance.....	13
7.0	PLAN DRAWINGS AND SPECIFICATIONS	13



List of Tables

Table 1 Initial and Future Water Flow Rates
Table 2 Well Supply Criteria
Table 3 Water Storage Requirements
Table 4 Water Supply System Distribution Requirements
Table 5 Water System Criteria
Table 6 Disinfection Criteria

List of Figures

Figure 1 Site Map

List of Appendices

Appendix A Design Drawings
Appendix B Technical Specifications
Appendix C Geotechnical Report
Appendix D Well Vulnerability Assessment Technical Memorandum
Appendix E Water System Model Technical Memorandum
Appendix F Drainage Calculations

MPB/JEC/ap
15226.doc

1.0 INTRODUCTION

The proposed project will involve residential and commercial development on property surrounding the existing Spring Mountain Motorsports Ranch (SMMR) track facilities in Pahrump, Nevada. The limits of the proposed residential and commercial developments are presented in Figure 1. In general, the proposed development includes:

- Develop 80 single family residential lots along the east and north sides of the race track
- Planned 62 acres of commercial development along Highway 160 frontage
 - 20 acres – Phase 1
 - 42 acres – Phase 2
- Connection to existing track facilities (currently on well and septic)

The proposed water facilities include well pumping facilities, storage tanks, a booster pump station, and transmission mains.

2.0 OWNER/OPERATOR

Double M Construction is responsible for development of the property for this project on behalf of SMMR. The systems will ultimately be turned over to and operated by Utilities Inc. of Central Nevada (UICN). The developer/owner's contact information and the operator contact for the SMMR water system is presented below:

Developer: Spring Mountain Motorsports Ranch
c/o Russ Meads
Double M Construction
2170 S. Cortina Ave.
Pahrump, NV 89048
Phone Number: (775) 751-3022

Operator: Utilities Inc. of Central Nevada
1240 E. State, Suite 115
Pahrump, NV 89048

Double M Construction has retained Golder Associates Inc. (Golder) to serve as the engineer-of-record for the water and wastewater infrastructure. Golder is responsible for preparation of the water and wastewater design and permit documents.



3.0 MASTER PLAN

The proposed SMMR project is a planned development located in Pahrump, Nevada in Nye County, Section 33 and 34, Township 21 South, Range 54 East, M.D.B.M. The proposed water system will initially serve approximately 80 single family units and 20 acres of commercial development that includes a 1250 seat movie theater, 97 room hotel, restaurants, retail shops, race track facilities, and RV Park. An additional 42.6 acres of additional commercial development is also planned to be serviced by the water system.

This report summarizes the water system design. Two well pumping facilities, two tanks, and a booster station will be located in the northwest corner of the property. Two transmission mains will supply the system with water from the booster station. The transmission main will split at the booster discharge then ultimately connect to the residential water pipeline to form a loop around the site to convey water to the residents and facilities throughout the site. Figure 1 is a Site Map that shows the general layout of the water supply facilities and the service area.

The design of the water system is being developed in accordance with the regulations set forth by the Nevada Division of Environmental Protection's (NDEP) Bureau of Safe Drinking Water (BSDW) in accordance with Nevada Administrative Code (NAC) 445A *Public Water Systems Design, Construction, Operation and Maintenance*.

Appendix A includes the proposed water system design drawings. Appendix B includes technical specifications for the system construction.



4.0 AREA CHARACTERISTICS

4.1 Adjacent Land Use

The SMMR Project is currently surrounded by the existing racetrack, open space, undeveloped land, and the proposed residential developments to the northeast. The site is bounded on the west side of the property by Nevada State Route 160. Private property south of the project site is currently undeveloped. BLM land surrounds the northern and eastern boundaries of the project site. The wells, water storage tanks, and booster pump station are located in the northwest corner of the property. See Figure 1 for the location of the water system in relation to the project site.

4.2 Topography

In general, the SMMR site is situated on an alluvial fan that slopes from northeast to southwest. The existing slopes vary between 2% and 4%. The Spring Mountain range front is to the northeast of the site and below Highway 160 to the southwest, the terrain transitions to the valley floor where slopes become less than 1%.

4.3 Flood Plains

The site location of the wells, water storage tanks, and booster pump station will not be affected by the 100-year storm event according to the Federal Emergency Management Agency (FEMA) Flood Insurance Rate Map for Nye County, Nevada and Incorporated Areas (Map No. 32023C8850E dated February 17, 2010).

4.4 Soils Information

A Geotechnical Investigation Report *is currently being completed* by Geo-tech, Inc. of Las Vegas, NV. A geotechnical review will be conducted for the well sites, the water storage tanks site, and the booster station site. The construction of the concrete slabs for the well buildings, booster pump station building, and generator pad will conform to the recommendations of the geotechnical engineer. The geotechnical report is included in Appendix C (*pending*).

5.0 WATER SYSTEM DESIGN CRITERIA

5.1 Water Flow Rates

The expected initial and future water flow rates that will be handled by the designed system were obtained from the Las Vegas Valley Water District (LVVWD) design code and commercial unit flow rates from the Water and Sewage Works 1978 Reference R-159. The size of each development (whether by seat, room, acre, or house) has an associated unit flow that is used to calculate the total water flows shown in Table 1.

Table 1: Initial and Future Water Flow Rates

Land Use Designation	Units	No. Units	Average Day gpm		Max Day gpm		Peak Hour gpm	
			Unit Flow	Total	Unit Flow	Total	Unit Flow	Total
Initial Expected Flow Rates								
Single Family Residential - Residential Equivalent (RE) ¹	RE	80	0.52	42	1.18	94	1.81	145
Commercial - Currently Planned²								
Retail A-F, Shops & C-Store	acres	5.37	2.1	11	3	16	4.6	25
Restaurants, Fast Food, Coffee, & Doughnut Shops 8 seats/1000 sf = 288 Seats (60 gpd/seat) ³	seats	288	0.04167	12	0.08334	24	0.12501	36
Hotels - 97 Rooms	rooms	97	0.29	28	0.36	35	0.45	44
Theater 1250 seat @ 5 gal/seat ³	seats	1,250	0.0035	4.4	0.007	8.8	0.0105	13
RV Park	gpm/acre	2.7	2.40	6.48	3.70	9.99	5.70	15.39
Driving School	gpm/acre	0.623	1.70	1.06	3.50	2.18	5.40	3.36
Commercial	gpm/acre	0.8	2.10	1.60	3.00	2.29	4.60	3.50
Existing Track Facility Water Use								
Metered Landscape Irrigation	gal/day	13,000		9.0		12.9		20
Potable Water Use - Based on fixture count	gal/day	11,509		8.0		11.4		18
Initial Flow Rates Total	gpm			124		217		322
Future Expected Flow Rates								
Commercial - Future Total Parcel Acreage	acres	42.6	2.1	89	3	128	4.6	196
Expected Future Flow Rates Total	gpm			213		345		518

- Notes: 1. Gallons per minute/Residential Equivalent (RE) metered service.
 2. Flow criteria is LVVWD unless otherwise noted.
 3. Water & Sewage Works 1978 Reference R-159.



5.2 Water Supply

The initial expected areas to be serviced by the water system at the time of completion of the proposed improvements include the development area shown in Figure 1. The development will consist of single family residences, stores, restaurants (including fast food and coffee shops), hotels, and a 1250 seat theater. Expected future areas to be serviced by the water system include approximately 42.6 acres of additional commercial development also shown on Figure 1. Table 1 provides a tabulation of the expected water demands for all types of facilities and provides the basis for the equivalent residential units.

Water services will be metered and the number of residential equivalent units (RE) for the initial phase is less than 250; therefore, the minimum water supply criteria used is 1.5 gallons per minute (gpm) per RE. For the future commercial requirements, a value of 1.2 gpm per RE is used. These values are in accordance with NAC as illustrated in Table 2.

Table 2: Well Supply Criteria

Calculation for Residential Equivalents Based on Average Flow Demand¹		
NAC Residential Equivalent (RE) Criteria	700	gal/RE
Planned Development Average Day Flow	123.5	gpm
NAC Residential Equivalent Calculation	254	RE
Well Supply for Under 250 RE	1.5	gpm
Well Capacity for Initial Planned Development	381	gpm
Future Total - Average Day Flow	213	gpm
NAC Residential Equivalent Calculation	438	RE
Well Supply for Over 250 RE	1.2	gpm
Well Capacity for Total Future Development ²	526	gpm

Notes: 1. Reference NAC 445A66735.1.b,c,d.

2. Install wells for future development conditions.

The maximum day water demand is 345 gpm as tabulated in Table 1 therefore a well capacity of 500 gpm will be more than sufficient based on the lower calculated maximum day demand. The well testing is not complete but it is expected that a production in excess of 500 gpm will be possible. Fire demand is provided from storage and with full flow supplied by the booster pump system.

5.3 Water Storage

Minimum required storage capacity, as regulated by the NAC 445A.6674, consists of Operating Storage, Emergency Reserve, and Fire Demand. The following table includes the requirements for determining each of the three volumes and the current and future storage needs.

Table 3: Water Storage Requirements

Storage Type	Value	Code	Current Plan (gal)	With Future Commercial (gal)
Operating Storage	700 gallons per RE (metered)	NAC 445A.66745	177,840	306,720
Emergency Reserve	75% of Operating Storage	NAC 445A.6675	133,380	230,040
Fire Demand	Based on Building Square Footage and Construction Type	2012 IFC ¹	570,000	570,000
Total Storage =			881,220	1,106,760

Notes: 1. 2012 IFC is the current International Fire Code.
Fire flow estimated at 2375 gpm for 4 hours.

5.4 Water Distribution

Distribution of water within the proposed water supply system must meet the pressure requirements set by the NAC. Additionally, Golder has chosen the LVVWD design standard as a basis to set the minimum static water pressure, which is not regulated by the NAC.

Table 4: Water Supply System Distribution Requirements

Pressure Type	Value	Code
Minimum Pressure: Max Day Demand during fire flow	20 psi	NAC 445A.6711
Normal Working Pressure: Max Day Demand	40 psi	NAC 445A.6711
Minimum Pressure: Peak Hour Demand	30 psi	NAC 445A.6711
Maximum Static Pressure	100 psi	NAC 445A.6711
Minimum Static Pressure	45 psi	LVVWD

To estimate flows within the system during an average day, maximum day, and peak hour Golder has chosen water demand values provided by the LVVWD and Water & Sewage Works 1978 Reference R-159. Values from these references are provided in Table 1 above.

5.5 Booster Pump Station Criteria

The booster pumps will pump water from the storage tanks to the distribution system. The pump system will be designed to meet the potable water supply demands as well as meeting the required fire flow while maintaining the minimum pressure criteria in Table 4. Due to the very large range of flow from a near zero flow at night during the initial development phase to the future maximum day and fire flow, the system consists of 5 duty pumps and one standby pump of identical sizes. Five pumps are needed for the maximum day and fire flow condition equal to 2,720 gpm (Fire 2,375 gpm plus Max Day 345 gpm). The pumps will be variable speed and capable of meeting very low flow. Night time near zero flow conditions will be met using pressure tanks and a by-pass valve to keep the pump from operating at shutoff head.

5.6 Water System Criteria Summary

Applying the regulation requirements and the basis for design information above, the following table presents the summary of the water system criteria developed.

Table 5: Water System Criteria Summary Table

Water System	Current Development Plan	Current Development Plan + Future Commercial
Water Supply ¹	381	526
Water Distribution: Average Day ²	124 gpm	213 gpm
Water Distribution: Maximum Day ²	217 gpm	345 gpm
Water Distribution: Peak Hour ²	322 gpm	518 gpm
Water Storage ³	881,000	1,107,000 gallons

Notes: 1. Water Supply was calculated per the NAC as described in Section 5.1 and 5.2.

2. Water Distribution was calculated using the LVVWD and the Water & Sewage Works 1978 Reference R-159 as described in Section 5.1 and 5.2.

3. Water Storage was calculated per the NAC as described in Section 5.3.

5.7 Disinfection

Sodium hypochlorite will be used to disinfect the well water prior to entering the storage tanks and a third system is provided at the booster pump station. The metering pumps are selected to provide chlorine dosage of the well discharge from 1.5mg/l to 5.0mg/l. The following Table 6 provides the criteria for the metering pumps and for the sodium hypochlorite storage. When the well water quality data is obtained from the well drilling samples, the anticipated chlorine dosage will be reviewed based on expected chlorine demand of the well water.

Table 6: Disinfection Criteria

Average Sodium Hypochlorite Feed		
Item	Quantity	Units
Required Minimum Residual Cl	0.2	mg/l
Average Water Demand Initial + Future	213	gpm
	0.307	mgd
Estimated Average Chlorine Dosage	1.5	mg/l
Daily Chlorine Use	3.8	lbs/day Chlorine
Sodium Hypochlorite NaOCl use 10%	38.4	lbs/day NaOCl
Daily NaOCl use	4.6	gal/day
Average Monthly Use @ 1.5 mg/l Dosage	138	gal/month
Well Dosage and Well Sodium Hypochlorite Feed		
Required Minimum Residual Cl	0.2	mg/l
Well Pump Rate	500	gpm
	0.720	mgd
Average Chlorine dosage	1.5	mg/l
Daily Chlorine Use	9.0	lbs/day Chlorine
NaOCl Feed Rate @ 10% for well	0.450	gal/hr
Maximum Expected Feed Rate	5	mg/l
Daily Chlorine Use	30.0	lbs/day Chlorine
NaOCl Feed Rate @ 10% for Well	1.500	gal/hr
Metering Pump Range For Well Discharge	0.45 gal/hr to 1.5 gal/hr	

6.0 WATER SYSTEM DESIGN

The proposed source of the water for the system includes two groundwater wells. The wells will each be equipped with a submersible pump that will convey water to the two (2) 550,000-gallon storage tanks. A booster pump station will be used to supply water transmission mains that distribute water to the residential and commercial facilities throughout the site. The overall system layout can be found on Drawing G1 in Appendix A.

6.1 Well Pumping Facilities

Two well locations will be developed in the northwest corner of the site to provide water to the facilities at the site. A well vulnerability assessment was completed per NAC 445A.6668 and is provided in Appendix D. The well construction and pump installation shall conform to NAC 445A.66855 through 445A.6693 inclusive.

6.1.1 Existing Well No. 1 Construction

Well No. 1 has been drilled and tested. A well completion report has been submitted to BSDW under separate cover. The water quality results indicated that all analytes tested for a new public drinking water source were within drinking water standards and below the Nevada and EPA Maximum Contaminant Levels (MCL). In addition, a step test and a constant-rate aquifer test were conducted in December 2015. The static water level in Well No. 1 was recorded at approximately 128.39 feet bgs. After 24 hours of pumping at an average rate of 357 gpm, the well had a total drawdown of 83.10 feet to a pumping water level of 211.40 feet bgs. The specific capacity at this pumping rate after 24 hours is about 4.30 gpm/ft. The aquifer transmissivity throughout the screened interval of the well is approximately 8,730 gpd/ft. The average hydraulic conductivity is approximately 29.10 gpd/ft² or 3.90 ft/day. No hydrologic boundaries were encountered during aquifer testing. A 500-gpm pump installed at 400 ft bgs is recommended for Well No. 1.

6.1.2 Proposed Well No. 2 Construction

Well No. 2 is currently schedule for development and testing within the next year. This well is planned to be constructed with the following components:

- 20-inch nominal diameter low-carbon steel (LCS) 0.375-inch conductor casing will be installed to 60 feet below ground surface (ft bgs). The surface casing will be installed and cemented into a 24-inch borehole.
- 12-inch nominal diameter LCS 0.250-inch wall thickness blank casing to approximately 400 ft bgs.
- 12-inch nominal diameter LCS 0.250-inch wall thickness screen casing with louvered screen perforations from approximately 400-700 ft bgs.



- Silica sand (filter pack) will fill the annular space from the total depth of the borehole to above the screened interval to the bottom of the sanitary seal.
- A 65-foot sanitary seal will be installed on top of the filter pack. The seal will consist of a 5-foot bentonite pellet/chip seal with a 60-foot cement grout seal to the surface.
- A steel plate will be installed at the surface to prevent any surface contamination from entering the annular space between the conductor casing and the blank casing stick up at the surface.
- A 2-inch access port will be installed in the casing to allow for water level measurements.

6.1.3 Well Pump Installation

The wells will be equipped with submersible pumps set on a 6-inch diameter steel drop pipe. An in-line check valve is located above the submersible pump. The pump discharges through a steel pipe that is fed through a watertight submersible split well seal. The well seal is equipped with a vent and cable hole.

Adjacent to the well head an air/vacuum valve will be installed and a well building will be constructed that will include a check valve, a flow meter, a sample port, and pump to waste piping. A pump to waste sump will be constructed at each well site for testing, maintenance, and start-up.

6.1.4 Chlorination

Three sodium hypochlorite disinfection systems will be provided, one at each well and one at the booster pump station. The well pumps are anticipated to be constant speed; therefore, the chlorine dosage can be manually set and operated with an ON/OFF interconnect with the respective well pump to control chlorination. Chlorination may or may not be needed at the booster pump station if the chlorine residual is sufficient leaving the storage tanks. If residual is found insufficient, chlorine can be added at the booster station until such time as the well chlorine dosage can be adjusted to maintain sufficient residual in the storage tanks.

Each chlorination system will consist of a dual wall storage tank, dual peristaltic metering pumps, and associated piping and valves. An eye wash station will be provided at each chlorination site. There will be access through a double door to the outside of the building for ease in refilling the storage tank.

The peristaltic pumps have a very wide range of selectable feed rates. The pumps will be equipped for a feed rate of 0.04-5.85 gph at a variable speed of 0.6 to 90 RPM. This dosage range will be modified as needed after well water quality data is obtained. A one hundred gallon sodium hypochlorite tank will be provided at each well and the booster pump station site. This volume will also be reviewed after well water quality data is obtained.

Chlorine analyzers will be installed on the discharge of the booster pump station and within both of the well buildings to continuously monitor disinfection levels.



6.2 Storage Tanks

The two welded steel water storage tanks will be 60-foot diameter, 28-foot high, with a 550,000 gallon storage capacity each. The welded steel tanks will be designed and constructed pursuant with AWWA D100. Each tank will have the following components:

- 18 inch diameter mushroom vent
- Removable silt stops for tank inlet and outlet
- Overflow weir box and overflow piping
- Two 30-inch diameter outward shell manways
- Interior stainless steel ladder
- Exterior stainless steel ladder with cage
- 30 inch square roof entry hatch
- Four 8 inch J-vents
- Liquid level indicator
- 12-inch diameter overflow line to outfall structure

The tanks will also be equipped with level transducers that will control the well pumps and monitor tank levels in the SCADA system (provided by others).

6.3 Booster Pump Station

The booster pump station will convey water from the storage tanks to the site distribution system. It will be built in accordance with NAC 445A.66965 through 445A.6706. The booster pump station will be a package system with variable speed pumps to maintain the required system pressure and meet the variable flow demand. A hydraulic water model of the system was developed using EPANET to verify that the system meets pressure regulations. The results of the model were summarized in a technical memorandum that can be found in Appendix E.

The specified pumps are 25 Hp Paco Series LC, Model 3070-7 with variable frequency drives. The package system will include six pumps, VFDs, check valves, isolation valves, relief valve, suction and discharge headers, power and control panel, and steel system skid with all necessary piping supports and wiring to complete the package. With 5 pumps running, the system will deliver 2,720 gpm at 55 psi.

The six pumps will be utilized to provide required flows to the system as well as fire flow demands. During lower demand periods, a bypass loop will re-circulate water to allow the pump(s) to operate at all times. Two (2) 185-gallon expansion tanks will be used to support the system in low-to-zero flow conditions.

The booster station pump station will be located inside the booster pump station building and is therefore protected from flood, fire, and other hazards. The pump station is readily accessible at all times to maintenance personnel. The finished grading of the site adjacent to the building directs surface drainage away from the building. Adequate space for the convenient and safe servicing of all equipment is provided.

Downstream of the package pump station, a flow meter will be installed to measure the rate of flow of discharge to the water system. Pump discharge pressure will be monitored by instrumentation provided with package pump station.

The booster station building will be designed and constructed by others in accordance with applicable electrical, building, and mechanical codes. A stand-by generator will also be installed to provide power during electrical outages.

6.4 Booster-Tank Site Improvements

The site containing the booster station building and water storage tanks will be enclosed within a 6-foot high block wall. Well No. 2 will also be located within the booster-tank site. The area around the booster station building will be paved with asphalt concrete and the area around the tanks will have a gravel surface. An automatic 16-foot wide rolling gate will accommodate secured access for the system operators. Fencing and surfacing will be provided by the site builder. Refer to Sheets C1 and C2 of the design drawings in Appendix A.

A drainage channel will be constructed above the booster-tank site on the north side. The channel will be trapezoidal with a 10-foot bottom width. The channel is designed to accommodate the 100-yr storm event flow of 42 cfs (flow rates provided by Impulse Engineering). Dual 24-inch diameter CMP culverts will pass this flow under the access road adjacent to the entrance gate. Drainage from within the booster-tank site will flow to a 4-foot by 4-foot drain inlet (DI) that will direct the onsite flow through a 12-inch diameter CMP pipe to the culvert outfall. Drainage calculations are included in Appendix F.

6.5 Transmission Mains

The proposed transmission mains will convey water from the booster pump station to supply water to the homes and businesses throughout the project site. The pipeline will exit the booster pump station and will transition from 12-inch ductile iron pipe to 12-inch PVC pipe 5 feet outside of the building. The PVC pipe will split into two directions. The North Water Distribution Line will be 10-inch PVC pipe that is directed east around the north edge of the facility as shown on Drawings P1 and P2. The South Water Distribution Line will be 12-inch PVC pipe that will flow south then east around the south side of the site as shown on Drawings P3 through P8. The water distribution lines will be connected to the residential water mains designed by Impulse Engineering as indicated on the Drawings in Appendix A. An 8-inch PVC pipe will

also be constructed to supply water to the proposed wastewater treatment plant as shown on Drawing P9. The transmission pipelines will be buried with a minimum 60 inches of cover unless the finish grade is provided before construction then the minimum cover can be 42 inches. Fire hydrants, isolation valves, and air/vacuum valves will be installed along the pipelines as shown on the Drawings.

6.6 Water System Operation and Maintenance

UICN will operate and maintain the water system. UICN will be responsible for developing the schedule and frequency of maintenance for the pump station that will be detailed in a Standard Operating, Maintenance, and Management document which will be submitted to NDEP prior to starting operation.

7.0 PLAN DRAWINGS AND SPECIFICATIONS

Water system construction drawings and corresponding technical specifications have been included in Appendix A and Appendix B, respectively. The drawings include site plan layout of the wells, storage tanks, and booster pump station (C1-C2), mechanical sheets of the wells, tanks, and booster station (M1-M10), plan and profile sheets of the distribution system (P1-P9), and general details (D1-D2).



FIGURES



- LEGEND**
- PROPOSED SERVICE TERRITORY ANNEXATION
 - PROPOSED APPROXIMATE RESIDENTIAL (80 LOTS)
 - PROPOSED APPROXIMATE COMMERCIAL (20 ACRES) PHASE 1
 - PROPOSED APPROXIMATE COMMERCIAL (42 ACRES) PHASE 2

ISSUED FOR CONSTRUCTION

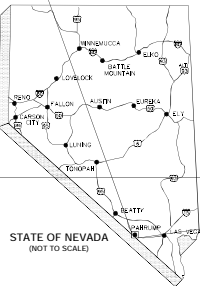

CLIENT
DOUBLE M CONSTRUCTION
C/O SPRING MOUNTAIN RACEWAY, LLC

PROJECT
WATER SYSTEM DESIGN
SPRING MOUNTAIN MOTORSPORTS RANCH
PAHRUMP, NEVADA

CONSULTANT

YYYYMMDD: 2015-07-16
PREPARED: EJM
DESIGN: AJS
REVIEW: JC
APPROVED: MPB

TITLE
SITE MAP

PROJECT No: 1520359 CONTROL Rev: A FIGURE 1



**APPENDIX A
DESIGN DRAWINGS**



Know what's below.
Call before you dig.

SPRING MOUNTAIN MOTORSPORTS RANCH WATER SYSTEM DESIGN DOUBLE M CONSTRUCTION PAHRUMP, NEVADA

ISSUED FOR CONSTRUCTION

OPERATOR

UTILITIES INC. OF CENTRAL NV
1246 STATE ST #115
PAHRUMP, NV 89048
PHONE: 775-727-7688

OWNER / DEVELOPER

SPRING MOUNTAIN MOTORSPORTS RANCH
DOUBLE M CONSTRUCTION
2110 S. CORTINA AVE.
PAHRUMP, NV 89048

BASIS OF BEARING

THE BASIS OF BEARING FOR THIS REAL PROPERTY DESCRIPTION IS THE NORTHEASTLY LINE OF BLOCK 1 OF "CALVADA VALLEY UNIT No. 1" IN THE TOWN OF PAHRUMP, COUNTY OF NVE, STATE OF NEVADA, WHICH BEARS SOUTH 61° 31' 15" EAST, AS PER MAP RECORDED IN FILE MAP No. 20290 IN THE OFFICE OF THE COUNTY RECORDER OF SAID COUNTY.

BENCHMARK

USGS 58B02

FOUND UNITED STATES GEOLOGICAL SURVEY (U.S.G.S) BRASS DISC ON ROD IN WHITE PVC PIPE, FLUSH WITH GROUND, STAMPED "S RBO 1981" LOCATED 2 METERS EAST OF A 4"x4" RIGHT-OF-WAY POST, 66 METERS SOUTH-SOUTHWEST OF STATE ROUTE 160 AT MILEPOST 3.25, APPROXIMATELY 5 KILOMETERS SOUTHWEST OF THE JUNCTION WITH STATE ROUTE 372, IN AN AREA OF HEAVILY PLOWED FURROWS IN GROUND.

NORTH AMERICAN VERTICAL DATUM 1988 (NAVD 88) AS PUBLISHED BY THE NEVADA DEPARTMENT OF TRANSPORTATION (DOT) SURVEY MONUMENT LOCATION INFORMATION SERVICE (LOIS) FOR "S RBO 2" RETRIEVED 7/24/2007.

METERS = 825.500
U.S. SURVEY FEET = 2741.136



Sheet Number	Sheet Title
T1	TITLE SHEET
P2	PROJECT NOTE SHEET
G1	GENERAL LAYOUT
G2	WATER SYSTEM PROCESS FLOW DIAGRAM
C1	WELL AND BOOSTER STATION SITE LAYOUT PLAN
C2	BOOSTER STATION GRADING PLAN
M1	WELL SITES YARD PIPING
M2	WELL HOUSE SECTION
M3	WELL DETAILS
M4	TANK SITE YARD PIPING
M5	TANK PLAN AND SECTIONS
M6	TANK DETAILS
M7	TANK DETAILS
M8	BOOSTER STATION PLAN
M9	BOOSTER STATION SECTIONS
M10	BOOSTER STATION DETAILS
P1	NORTH DISTRIBUTION MAIN PLAN AND PROFILE (1 OF 2)
P2	NORTH DISTRIBUTION MAIN PLAN AND PROFILE (2 OF 2)
P3	SOUTH DISTRIBUTION MAIN PLAN AND PROFILE (1 OF 6)
P4	SOUTH DISTRIBUTION MAIN PLAN AND PROFILE (2 OF 6)
P5	SOUTH DISTRIBUTION MAIN PLAN AND PROFILE (3 OF 6)
P6	SOUTH DISTRIBUTION MAIN PLAN AND PROFILE (4 OF 6)
P7	SOUTH DISTRIBUTION MAIN PLAN AND PROFILE (5 OF 6)
P8	SOUTH DISTRIBUTION MAIN PLAN AND PROFILE (6 OF 6)
P9	WWTP DISTRIBUTION LINE PLAN AND PROFILE
D1	GENERAL DETAILS (1 OF 2)
D2	GENERAL DETAILS (2 OF 2)

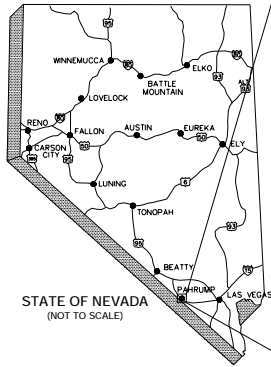

REFERENCE-GOOGLE EARTH

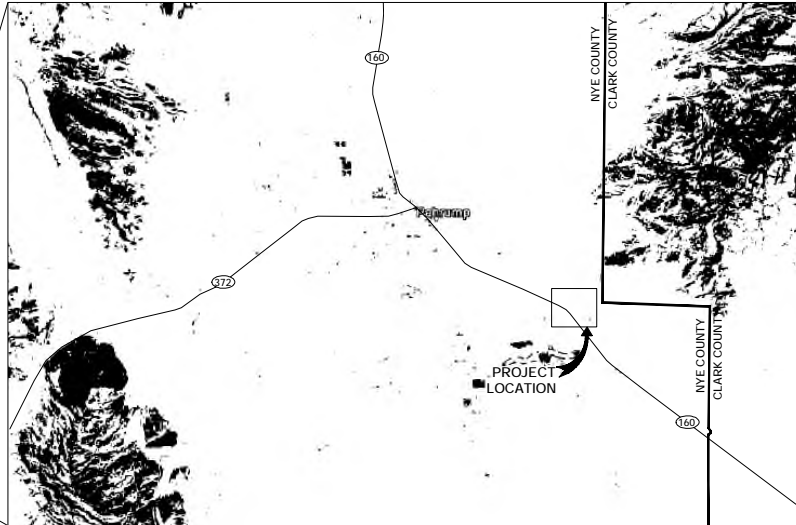

LOCATION MAP

CLIENT
DOUBLE M CONSTRUCTION
C/O SPRING MOUNTAIN RACEWAY, LLC

CONSULTANT



RENO OPERATIONS
595 DOUBLE EAGLE CT. #1000
RENO, NEVADA 89521
USA
1-11(775) 828-9404
www.golder.com

PROJECT
WATER SYSTEM DESIGN
SPRING MOUNTAIN MOTORSPORTS RANCH
PAHRUMP, NEVADA

TITLE SHEET

PROJECT No.
1520359

Rvw. 1 of 27 DRAWING
B 11

GENERAL NOTES

- 1. CONTRACTOR SHALL PROVIDE ALL NECESSARY HORIZONTAL AND VERTICAL TRANSITION BETWEEN NEW CONSTRUCTION AND EXISTING SURFACES TO PROVIDE FOR PROPER DRAINAGE, REGRESS, AND EGRESS. EXTENT OF TRANSITIONS TO BE DETERMINED BY THE NVE COUNTY PUBLIC WORKS DEPARTMENT OR PARKHURP BUILDING AND SAFETY.
2. LOCATIONS OF UNDERGROUND UTILITIES SHOWN ON THE DRAWINGS WERE OBTAINED FROM RECORDS RECEIVED FROM THE RESPONSIBLE UTILITY CITY. NEITHER THE OWNER NOR ENGINEER ASSUMES ANY RESPONSIBILITY FOR UTILITIES OR STRUCTURES NOT IN THE LOCATION SHOWN PRIOR TO START OF CONSTRUCTION. THE CONTRACTOR IS RESPONSIBLE FOR VERIFY FIELD LOCATIONS.
3. 48 HOURS PRIOR TO START OF CONSTRUCTION THE CONTRACTOR SHALL CONTACT ALL UTILITY COMPANIES THAT MAY HAVE FACILITIES IN THE AREA OF CONSTRUCTION AND OBTAIN ALL NECESSARY PERMITS PRIOR TO COMMENCEMENT OF WORK.
4. THE CONTRACTOR SHALL TAKE ALL PRECAUTIONARY MEASURES NECESSARY TO PROTECT EXISTING IMPROVEMENTS WHICH ARE TO REMAIN IN PLACE FROM DAMAGE. ALL SUCH IMPROVEMENTS OR STRUCTURES DAMAGED BY THE CONTRACTOR'S OPERATIONS SHALL BE REPAIRED OR RECONSTRUCTED TO SATISFACTORY TO THE ENGINEER AT THE EXPENSE OF THE CONTRACTOR. ALL BARRICADING AND TEMPORARY TRAFFIC CONTROL DEVICES OR METHODS USED IN CONSTRUCTION SHALL BE IN ACCORDANCE WITH THE MANUAL ON UNIFORM TRAFFIC CONTROL DEVICES, LATEST EDITION.
5. THE QUANTITIES SHOWN IN THE DRAWINGS ARE APPROXIMATE ONLY BEING GIVEN AS A BASIS FOR THE COMPARISON OF BIDS. THE OWNER DOES NOT EXPRESS OR BY IMPLICATION, AGREE THAT THE ACTUAL AMOUNT OF WORK WILL CORRESPOND THERETO. BUT RESERVES THE RIGHT TO MAKE SUCH ADJUSTMENTS, DEVIATIONS, ADDITIONS TO OR DECREASE IN QUANTITY AND SPECIFICATIONS, INCLUDING THE RIGHT TO INCREASE OR DECREASE THE QUANTITY OF ANY ITEM OR PORTION OF THE WORK. AS MAY BE DEEMED BY THE OWNER TO BE NECESSARY. ANY SUCH CHANGES WILL SET FORTH IN A CONTRACT CHANGE ORDER WHICH WILL SPECIFY IN ADDITION TO THE WORK TO BE DONE IN CONNECTION WITH THE CHANGE MADE, ADJUSTMENT OF CONTRACT TIME, IF ANY, AND THE BASIS OF COMPENSATION FOR SUCH WORK. A CONTRACT CHANGE ORDER WILL NOT BE EFFECTIVE UNTIL APPROVED BY THE OWNER.
6. THE CONTRACTOR SHALL BE RESPONSIBLE FOR THE VERTICAL ADJUSTMENT OF ALL EXISTING SANITARY AND SEWER MAINS PRIOR TO THE FINAL FRESH GRADES AS SHOWN IN THE CONTRACT DOCUMENTS.
7. ALL STANDARD AND MATERIALS FOR THIS PROJECT SHALL BE IN ACCORDANCE WITH THE FOLLOWING REGULATIONS:
8.1. STANDARD DETAILS AND SPECIFICATIONS FOR PUBLIC IMPROVEMENTS WITHIN THE PARKHURP REGIONAL PLANNING DISTRICT, JUNE 1, 1998.
8.2. STANDARD SPECIFICATIONS FOR PUBLIC WORKS CONSTRUCTION PUBLISHED BY THE REGIONAL TRANSPORTATION COMMISSION OF WASHOE COUNTY, ET AL, 2004 EDITION.
8.3. MANUAL ON UNIFORM TRAFFIC CONTROL DEVICES (2003 EDITION)
8.4. UNIFORM DESIGN AND CONSTRUCTION STANDARDS FOR WATER DISTRIBUTION SYSTEMS (2003 EDITION)
8.5. DESIGN AND CONSTRUCTION STANDARDS FOR WASTEWATER DISTRIBUTION SYSTEMS (2003 EDITION)
9. REMOVAL OR RELOCATION OF POWER POLES, TELEPHONE POLES, JOINTLY OWNED POLES AND APPURTENANCES WHICH INTERFERE WITH IMPROVEMENTS REQUIRED TO BE CONSTRUCTED UNDER THIS CONTRACT, SHALL BE THE RESPONSIBILITY OF THE CONTRACTOR.
10. THE CONTRACTOR SHALL BE RESPONSIBLE FOR THE VERTICAL ADJUSTMENT OF ALL TELEPHONE COMPANY MAINS AS TO THE FINAL FINISH GRADES AS SHOWN ON THE CONTRACT DRAWINGS.
11. ALL SITE GRADING WORK SHALL BE IN STRICT ACCORDANCE WITH THE SOILS REPORT FOR THE SITE. ALL WORK SHALL BE PERFORMED UNDER THE DIRECTION OF A REGISTERED PROFESSIONAL ENGINEER.
12. ALL OFF SITE IMPROVEMENT CONSTRUCTION SHALL CONFORM TO THE NVE COUNTY STANDARD DETAILS AND SPECIFICATIONS FOR PUBLIC IMPROVEMENTS WITHIN THE PARKHURP REGIONAL PLANNING DISTRICT.
13. CURBS AND GUTTERS WITH A GRADE OF LESS THAN 4% OF ONE PERCENT SHALL BE CONSTRUCTED BY FORMING. EACH JOINT SHALL BE CHECKED FOR GRADE PRIOR TO CONSTRUCTION AND WATER TESTED AS SOON AS POSSIBLE AFTER CONSTRUCTION.
14. THE CONTRACTOR SHALL OBTAIN THE NECESSARY ENCROACHMENT PERMITS FOR CONSTRUCTION OF THE PROJECT.
15. SIDEWALK RAMPS SHALL BE CONSTRUCTED IN EACH CORNER OF AN INTERSECTION PER THE NVE COUNTY STANDARD DETAILS AND SPECIFICATIONS FOR PUBLIC IMPROVEMENTS WITHIN THE PARKHURP REGIONAL PLANNING DISTRICT.
16. SLOPES STEEPER THAN 4:1 AND FINE GRADING MATERIALS THAT HAVE BEEN DESTROYED DURING AND S/LT MATERIALS, SHOULD BE PROTECTED WITH BURLAP AND OTHER EROSION CONTROL METHODS, UNLESS OTHERWISE SPECIFIED BY THE LANDSCAPE DRAWINGS AND SPECIFICATIONS OR THE SOILS REPORT.
17. CONTRACTOR SHALL DETERMINE HIS OWN FOOTING OR BASEMENT EXCAVATION QUANTITIES, EVEN THOUGH SHOWN ON ROUGH GRADING PLANS. STRUCTURE BACKFILL COSTS SHALL BE INCLUDED IN THE COST OF THE STRUCTURE, UNLESS OTHERWISE SPECIFIED IN THE CONTRACT DOCUMENTS.
18. THE CONTRACTOR SHALL OBTAIN ALL REQUIRED PERMITS FROM THE APPROPRIATE AGENCIES.
19. CONTRACTOR SHALL BE RESPONSIBLE FOR PROVIDING EROSION CONTROL MEASURES (SILT FENCES, STRAW BALES, ETC.) DURING CONSTRUCTION TO PROTECT THE ADJACENT PROPERTIES FROM SEDIMENTATION.
20. THE CONSTRUCTION OF ALL STREETS SHALL BE INSPECTED BY THE NVE COUNTY PUBLIC WORKS DEPARTMENT.
21. FINISHED GRADE OF A.C. PAVEMENT SHALL BE 15" ABOVE UP OF CURB AFTER COMPACTION.
22. CONTRACTOR SHALL SUBMIT A DUST CONTROL PLAN AND OBTAIN APPROVAL FROM THE NVE COUNTY PLANNING DEPARTMENT FOR DISTURBANCES OVER 1/2 ACRE.
23. CONTRACTOR SHALL OBTAIN A SURFACE AREA DISTURBANCE CLASS 2 PERMIT FROM THE STATE OF NEVADA FOR DISTURBANCES OVER 1/2 ACRE IN ADDITION TO AN APPROVED NVE COUNTY DUST CONTROL PLAN.
24. STOCK PILES OF EARTH AND OTHER CONSTRUCTION RELATED MATERIAL MUST

- BE PROTECTED FROM BEING TRANSPORTED FROM THE SITE BY THE FORCES OF WIND OR WATER. REQUIREMENTS IDENTIFIED IN THE NVE COUNTY APPROVED DUST CONTROL PLAN AND/OR STATE OF NEVADA SURFACE AREA DISTURBANCE CLASS 2 PERMIT SHALL BE FOLLOWING:
24.1. ALL WORK MUST COMPLY WITH THE FOLLOWING SPECIFICATIONS:
24.1.1. 2006 INTERNATIONAL BUILDING CODE
24.1.2. 2006 INTERNATIONAL RESIDENTIAL CODE
24.1.3. 2006 INTERNATIONAL PROPERTY MAINTENANCE CODE
24.1.4. 2003 INTERNATIONAL FIRE CODE
24.1.5. 2003 INTERNATIONAL ENERGY CONSERVATION CODE
24.1.6. 2006 UNIFORM MECHANICAL CODE
24.1.7. 2006 UNIFORM PLUMBING CODE
24.1.8. 2006 NATIONAL ELECTRICAL CODE
24.1.9. NEVADA ADMINISTRATIVE CODE REGULATIONS
24.1.10. NVE COUNTY CODE
24.1.11. NVE COUNTY CODE
24.1.12. NVE COUNTY CODE
24.1.13. NVE COUNTY CODE
24.1.14. NVE COUNTY CODE
24.1.15. NVE COUNTY CODE
24.1.16. NVE COUNTY CODE
24.1.17. NVE COUNTY CODE
24.1.18. NVE COUNTY CODE
24.1.19. NVE COUNTY CODE
24.1.20. NVE COUNTY CODE
24.1.21. NVE COUNTY CODE
24.1.22. NVE COUNTY CODE
24.1.23. NVE COUNTY CODE
24.1.24. NVE COUNTY CODE
24.1.25. NVE COUNTY CODE
24.1.26. NVE COUNTY CODE
24.1.27. NVE COUNTY CODE
24.1.28. NVE COUNTY CODE
24.1.29. NVE COUNTY CODE
24.1.30. NVE COUNTY CODE
24.1.31. NVE COUNTY CODE
24.1.32. NVE COUNTY CODE
24.1.33. NVE COUNTY CODE
24.1.34. NVE COUNTY CODE
24.1.35. NVE COUNTY CODE
24.1.36. NVE COUNTY CODE
24.1.37. NVE COUNTY CODE
24.1.38. NVE COUNTY CODE
24.1.39. NVE COUNTY CODE
24.1.40. NVE COUNTY CODE
24.1.41. NVE COUNTY CODE
24.1.42. NVE COUNTY CODE
24.1.43. NVE COUNTY CODE
24.1.44. NVE COUNTY CODE
24.1.45. NVE COUNTY CODE
24.1.46. NVE COUNTY CODE
24.1.47. NVE COUNTY CODE
24.1.48. NVE COUNTY CODE
24.1.49. NVE COUNTY CODE
24.1.50. NVE COUNTY CODE

- REQUIREMENTS OF THE PRELIMINARY SOILS REPORTS DATED (DATED MARCH 21, 2008 BY NEVADA GEOTECH INC. JOB REF. NO. 07-083)
9. CLEAR ALL AREAS OF FILL OF VEGE TATION TO A DEPTH OF SIX (6) INCHES OR MORE. NO FILL IS TO BE PLACED UNTIL PREPARATION OF ORIGINAL GROUND IS APPROVED BY THE ENGINEER. OR PARKHURP BUILDING AND SAFETY OR NVE COUNTY PUBLIC WORKS DEPARTMENT.
10. ALL GRADING, SURFACE MATERIAL, AND DEBRIS SHALL BE STRIPPED PRIOR TO ANY GRADING OPERATION AND TRANSPORTED AWAY FROM ALL AREAS THAT ARE TO RECEIVE STRUCTURES OR ENGINEERED FILL.
11. FOUNDATION BEARING VALUE SHALL BE AT LEAST 1500 PSF OR AS DETERMINED IN THE SOILS REPORT IN COMPLIANCE WITH THE INTERNATIONAL BUILDING CODE.
12. COMPACTION SHALL BE A MINIMUM OF NINETY FIVE PERCENT (95%). CONTRACTOR TESTS SHALL BE MADE FOR EACH 18" INCHES OF FILL OR PER SOIL ENGINEER'S RECOMMENDATION AND THE INTERNATIONAL BUILDING CODE.
13. FILL SHALL BE PLACED IN LIFTS OF EIGHT (8) INCHES OR LESS AND SURFICENT MOISTURE ADDED AND MANUALLY COMPACTED TO ACHIEVE THE REQUIRED PERCENT OF COMPACTION.
14. ROADS GREATER THAN SIX (6) INCHES IN DIAMETER MAY BE PLACED IN FILL.
15. MANHOLE AND FILL SLOPES SHALL BE 2:1.
16. ALL GRADED AREAS SHALL BE BULGED OUT A MINIMUM OF 2% TO ALLOW DRAINAGE STRUCTURE, OR A MINIMUM OF 1% IF SITE MEETS EXCEPTIONS LISTED IN THE INTERNATIONAL BUILDING CODE AND IS WAVED BY THE BUILDING OFFICIAL.
17. BUILDING PAD AND GRADING PLAN CERTIFICATION SHALL BE COMPLETED BY A LICENSED ENGINEER AS REQUIRED BY NVE COUNTY PUBLIC WORKS AND PARKHURP BUILDING AND SAFETY STAFF IN ACCORDANCE WITH THE INTERNATIONAL BUILDING CODE, AND STATE LAW.
18. ALL BORROW LOCATIONS SHALL BE APPROVED BY NVE COUNTY PUBLIC WORKS AND THE SOILS ENGINEER.

- THE CONTRACTOR SHALL INSTALL BLOW-OFF ASSEMBLIES AS DETAILED ON THE PLANS.
3. FIRE HYDRANT ASSEMBLIES FIRE HYDRANT ASSEMBLIES SHALL INCLUDE THE CONNECTION TO THE MAIN AND SHALL CONSIST OF FIRE HYDRANT AND APPURTENANCES IN ACCORDANCE WITH THESE SPECIFICATIONS AND AS SHOWN ON THE STANDARD DRAWINGS (P.1, W.1, W.1.1, OR W.1.2).
4. VALVE BOXES AND COVERS VALVE BOXES FOR IRON VALVES SHALL BE INSTALLED WITH EITHER 8" OR 10" SCHEDULE 40 PVC PIPE. THE ENTIRE VALVE BOX ASSEMBLY SHALL BE FURNISHED AND INSTALLED AS SHOWN ON THE PLANS OR IN THE STANDARD DRAWINGS. METEORIC RODS SHALL BE AS MANUFACTURED BY AMVIC CAST OR APPROVED EQUAL.
5. FLANGE INSTALLATION METHODS FLANGE INSTALLATION METHODS SHALL BE INSTALLED AS SHOWN ON APPROVED PLANS OR DIRECTED BY UTILITIES, INC. AND SHALL BE CALQUIP, INC. RUBBER-COATED GASKET KITS AND APPROVED EQUAL.

- REPORTED 4:09 FILL SAND HAVING A MINIMUM OF EQUIVALENCY OF 54% D50. THE SIX (6) INCH BEDDING LAYER SHALL BE PLACED AND COMPACTED TO A MINIMUM OF NINETY PERCENT OF THE MAXIMUM DENSITY OF THE MATERIAL AT OPTIMUM MOISTURE CONTENT. THE PIPE SHALL THEN BE INSTALLED ABOVE WHICH THE REMAINING UNMOTTLED PIPE ZONE MATERIAL UP TO TWELVE (12) INCHES ABOVE THE TOP OF THE PIPE SHALL BE PLACED AND COMPACTED TO 95% RELATIVE COMPACTION.
8. BACKFILLING PIPE TRENCHES ABOVE THE PIPE ZONE SHALL BE A STRUCTURAL FILL ACCOMPLISHED BY FILLING AND COMPACTING THE TRENCH IN LIFTS OF DEPTH THAT SHALL PERMIT OBTAINING A MINIMUM COMPACTION OF NINETY PERCENT OF THE MAXIMUM DENSITY OF THE MATERIAL AT OPTIMUM MOISTURE CONTENT. ALL BACKFILL MATERIALS SHALL BE PLACED IN SUCH A MANNER AS TO NOT DISTURB THE PIPE OR DAMAGE ITS COATING. IMPACT FREE FALL HYDRO AMORPH OR SIMILAR CAPTIONED EQUIPMENT SHALL NOT BE USED FOR COMPACTION IN PIPE TRENCH SYSTEMS. FRESHLY MIXED PORTLAND CEMENT TREATED BACKFILL MATERIAL WILL NOT BE ALLOWED IN TRENCH WITH THE EXCEPTION OF CROSS-CORROSION, ETC. AS DETERMINED BY UTILITIES, INC. INSPECTOR OR BY WRITTEN PERMISSION BY UTILITIES, INC.
5. HOT TAPPING OF EXISTING WATERLINE CONTRACTORS SHALL EITHER BE PERFORMED BY UTILITIES, INC. OR AN EXPERIENCED LICENSED CONTRACTOR SPECIALIZING IN S&D WORK. CONTRACTORS SHALL HAVE A PROVED ABILITY TO PERFORM HOT TAP, HOLD A CURRENT UNDERGROUND CONTRACTORS LICENSE, AND CARRY SUFFICIENT INSURANCE AS DETERMINED BY UTILITIES, INC. APPROVED BY UTILITIES, INC. PRIOR TO COMMENCING S&D WORK. EXISTING MAINS TO BE TAPPED MUST BE CLEANED. THE AREA AROUND TO BE CLEANED SHALL BE EITHER THE DIAMETER OF THE HOT TAP PLUS FIVE (5) INCHES OR THE FULL DIAMETER OF THE MAIN TO BE TAPPED WHEN FULL-CIRCLE REINFORCEMENT IS REQUIRED. THE FOLLOWING STEPS ARE THEN FOLLOWED PRIOR TO HOT TAPPING: DUCTILE IRON AND PVC MAINS: MECHANICAL TAPPING SLICES ARE REQUIRED, AFTER CLEANING, THE SLICES SHALL BE WETTED TO THE MAIN AND A RING FLANGE PLACED ON THE NOZZLE. AN AIR TEST SHALL THEN BE PERFORMED AS DESCRIBED ABOVE.

UTILITIES INC. OF CENTRAL NEVADA PIPELINE NOTES

- 1. POLYVNYL CHLORIDE (PVC) PIPE (PVC) POLYVNYL CHLORIDE (PVC) PIPE AND JOINTS SHALL BE DESIGNED AND MANUFACTURED IN ACCORDANCE WITH ANSIAWMA STANDARD C905, LATEST REVISION, AND APPENDIX A OF S&D STANDARD.
3. PIPE MARKING SHALL BE IN ACCORDANCE WITH ANSIAWMA STANDARD C905 INCLUDING THE SEAL MARK OF THE TESTING AGENCY WHICH VERIFIED THE STABILITY OF THE PIPE MATERIAL FOR POTABLE WATER SERVICE.
3.1 FITTINGS FOR POLYVNYL CHLORIDE (PVC) PIPE FITTINGS SHALL SEE DUCTILE IRON AND SHALL CONFORM TO THE LATEST REVISION OF EITHER ANSIA WMA STANDARD C15040 TO 10 ANSIA WMA C15040 (S3 CLASS 350) ALL FITTINGS AND ACCESSORIES SHALL BE FURNISHED WITH MECHANICAL JOINTS IN ACCORDANCE WITH THE LATEST REVISION OF ANSIAWMA STANDARD C1511 (1). ALL FITTINGS JOINTS SHALL HAVE RESTRAINING DEVICES IN ACCORDANCE WITH THE LATEST REVISION OF ANSIAWMA STANDARD C1511 (1). MECHANICAL RESTRAINT JOINTS RESTRAINED JOINT FITTINGS SHALL BE PROVIDED AT ALL TEES, CROSSERS, REDUCERS, BENDS, CAPS, FLANS, AND WAVES SUCH THAT THE PIPE IS FULLY RESTRAINED IN ANY ONE GIVEN DIRECTION.

ISSUED FOR CONSTRUCTION

- CHANGES IN ALIGNMENT AND GRADE MAY BE EFFECTING THE PIPE UNITS AT JOINTS AS ENGAGED HEREIN AND UNDER SHORTER THAN STANDARD LENGTH MAY BE REQUIRED. JOINTS SHALL NOT BE DEFLECTED MORE THAN HALF (1/2) OF THE MANUFACTURERS RECOMMENDATION. PIPE WITH FACTORY INSTALLED COUPLINGS SHALL BE DEFLECTED NOT MORE THAN HALF (1/2) OF THE ALLOWABLE DEFLECTION FOR FIELD INSTALLED COUPLINGS. IDENTIFICATION WIRE IDENTIFICATION WIRE SHALL BE INSTALLED WITH POLYVNYL CHLORIDE (PVC) PIPE. THE WIRE SHALL BE ISOLATED FOURTEEN (14) GAUGE COPPER AND SHALL BE INSTALLED AS DETAILED ON THE STANDARD DRAWING W.8 IN THE UTILITIES, INC. STANDARDS SPECIFICATIONS AND DRAWINGS.
4. CONNECTIONS ALL CONNECTIONS FOR WATER SERVICE SHALL BE MADE WITH A JOINS MODEL J.3 P.94 OR APPROVED EQUAL. BRONZE SERVICE SADDLE SET AS SHOWN ON THE STANDARD DRAWING. UNDERGROUND MARKING TAPE UNDERGROUND MARKING TAPE SHALL BE INSTALLED WITH ALL PVC PIPE.

UTILITIES INC. OF CENTRAL NEVADA PIPELINE INSTALLATION NOTES

- 1. ANCHOR AND THREST BLOCKS SHALL BE INSTALLED AT FITTING AND VALVES AND DIRECTED BY UTILITIES, INC. IN ACCORDANCE WITH DETAILS SHOWN ON STANDARD DRAWING W.4 IN THE UTILITIES, INC. STANDARDS, SPECIFICATIONS AND DRAWINGS.
2. HYDROSTATIC TEST ACCEPTED THE PIPE SHALL BE SUBJECTED TO A HYDROSTATIC PRESSURE TEST AS REITERATED SPECIFIED. UTILITIES, INC. SHALL BE NOTIFIED TWENTY FOUR (24) HOURS PRIOR TO TESTING. AN INSPECTOR SHALL BE PRESENT.
3. DISINFECTION OF WATER MAINS AND SERVICES ALL WATER MAINS, WATER SERVICES, ATTACHED APPURTENANCES, AND TEMPORARY CONNECTIONS, IF ANY, SHALL BE DISINFECTED IN ACCORDANCE WITH ANSIA C601 AND THE FOLLOWING REQUIREMENTS:
A. CHLORINE SHALL BE APPLIED TO 144 WATER IN SUFFICIENT QUANTITY TO PROVIDE A DOSE OF NOT LESS THAN FIFTY (50) PARTS PER MILLION (PPM) IN ALL SECTIONS OF THE LINE, SERVICE AND APPURTENANCES. FIFTY (50) PARTS PER MILLION (PPM) IN ALL SECTIONS BEING DISINFECTED AT THE END OF THE TWENTY FOUR (24) HOUR PERIOD.
C. CHLORINE TABLETS SHALL BE ATTACHED WITH FORMICATE NO. 1 RECHLORINATION SHALL BE DONE USING CHLORINE GAS WATER SOLUTION. CHLORINE DOSE IS NOT TO EXCEED ONE HUNDRED (100) PPM UNDER NORMAL CONDITIONS.
4. EXCAVATION OF FINISH TRENCH PLACING OF PIPE ZONE BEDDING AND BACKFILL MATERIAL. ALL PIPE ZONE BACKFILL FROM DEPTH OF SIX (6) INCHES BELOW THE BOTTOM OF THE PIPE TO TWELVE (12) INCHES ABOVE THE TOP OF THE PIPE SHALL BE PRESENT.

Table with 2 columns: ABBREVIATIONS and DESCRIPTION. Rows include NTS (NOT TO SCALE), TYP (TYPICAL), SWR (SCHEDULE WATER), AC (ACRE), MIN (MINIMUM), MAX (MAXIMUM), DIM (DIMENSION), DIA (DIAMETER), DIM (DIMENSION RATIO), ELEV (ELEVATION), FT (FEET), HDP (HIGH DENSITY POLYETHYLENE), PVC (POLYVNYL CHLORIDE), IN (INCHES), INSET (ALIGNMENT BEGINNING), EP (TANGENT TO CURVE INTERSECTION), PT (CURVE TANGENT INTERSECTION), PC (TANGENT-CURVE INTERSECTION), GAGE (GAGE), SCH (INNER DIAMETER), OD (CENTER LINE), FCA (FLANGED COUPLING ADAPTOR).

CLIENT: DOUBLE M CONSTRUCTION C/O SPRING MOUNTAIN RACEWAY, LLC
CONSULTANT: [Logo]
RENO OPERATIONS 995 DOUBLE EAGLE CT #1000 RENO, NEVADA 89521 USA 1-11(775) 328-9604 www.gbls.com
PROJECT: WATER SYSTEM DESIGN SPRING MOUNTAIN MOTORSPORTS RANCH PAHRUMP, NEVADA
TITLE: PROJECT NOTE SHEET
PROJECT No. 1520359 Rev. B 2 of 27 DRAWING T2

Table with 4 columns: No., DATE, DESCRIPTION, ACTION. Row 1: 0 2016-04-29 ISSUED FOR CONSTRUCTION. Row 2: Rev. VMM:MDG DESCRIPTION. Row 3: EAC MEB JC MPB PREPARED DESIGN REVIEW APPROVED.

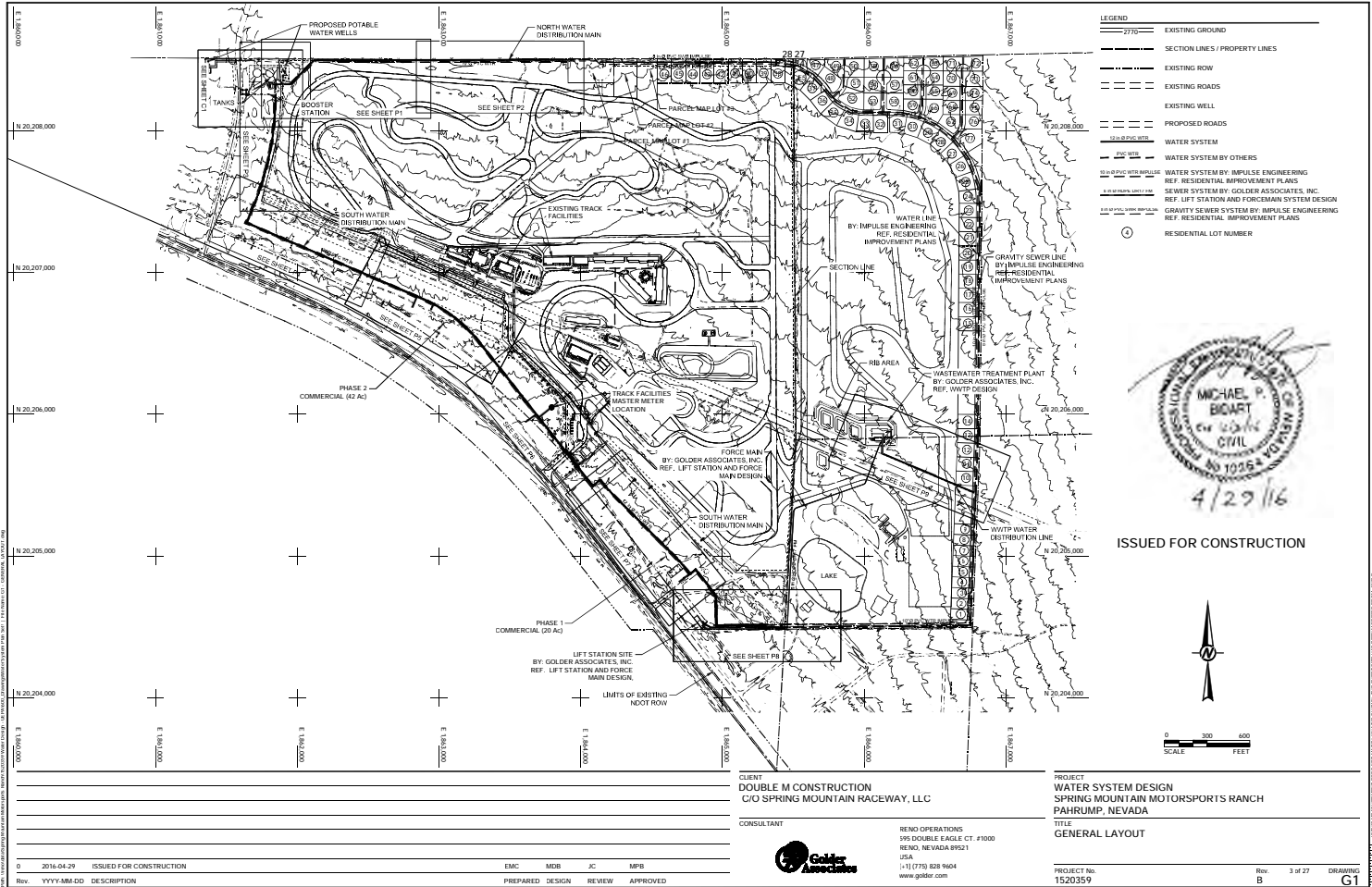

CLIENT DOUBLE M CONSTRUCTION C/O SPRING MOUNTAIN RACEWAY, LLC				PROJECT WATER SYSTEM DESIGN SPRING MOUNTAIN MOTORSPORTS RANCH PAHRUMP, NEVADA			
CONSULTANT 				TITLE GENERAL LAYOUT			
RENO OPERATIONS 995 DOUBLE EAGLE CT. #1000 RENO, NEVADA 89521 USA 1-1-1 (775) 828-9604 www.golder.com				PROJECT No. 1520359			
0 2016-04-29 ISSUED FOR CONSTRUCTION				Rev. 3 of 27 DRAWING G1			
Rev.	YYYY-MM-DD	DESCRIPTION	EMC	MDR	JC	MPB	
			PREPARED	DESIGN	REVIEW	APPROVED	

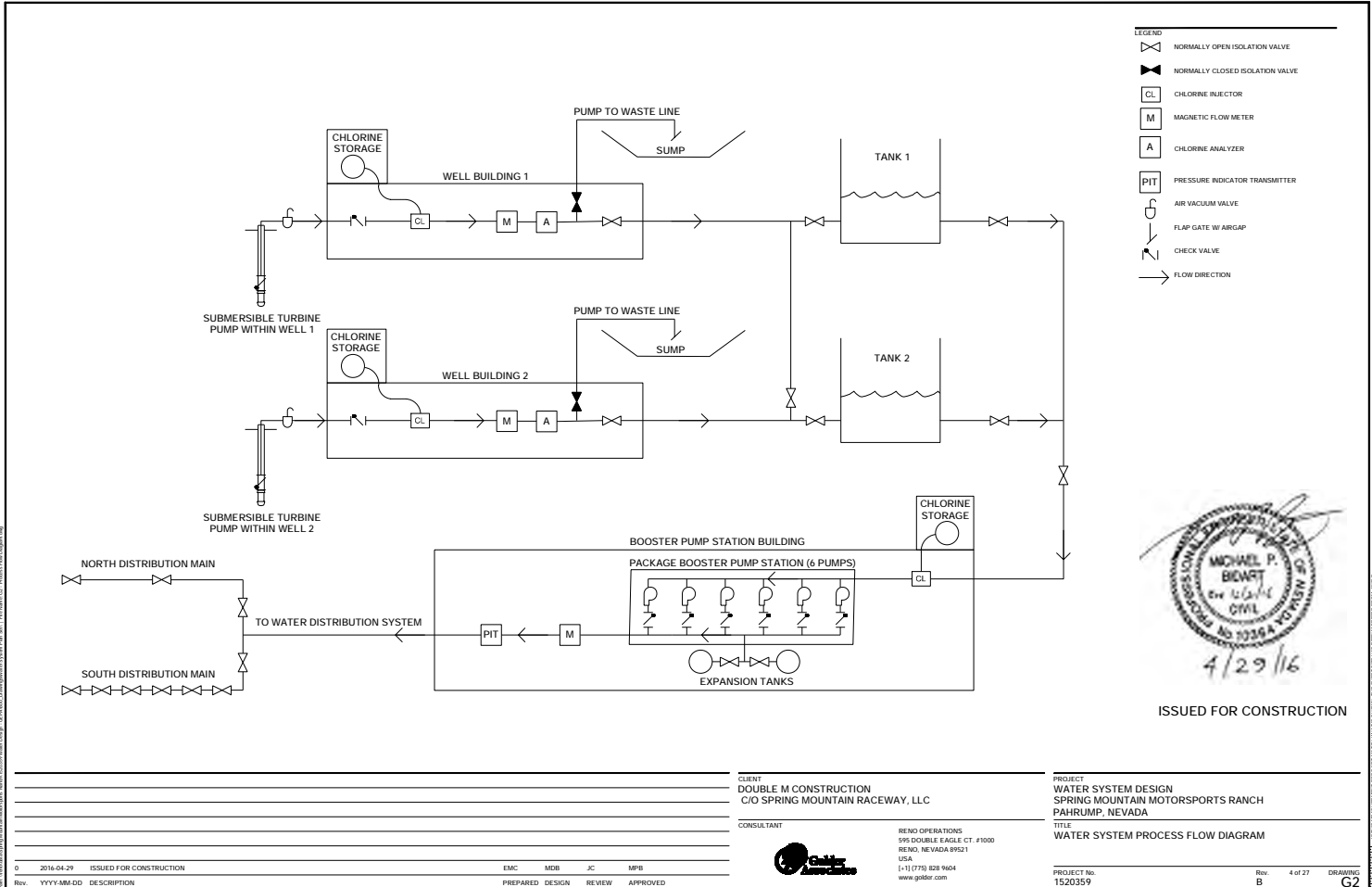

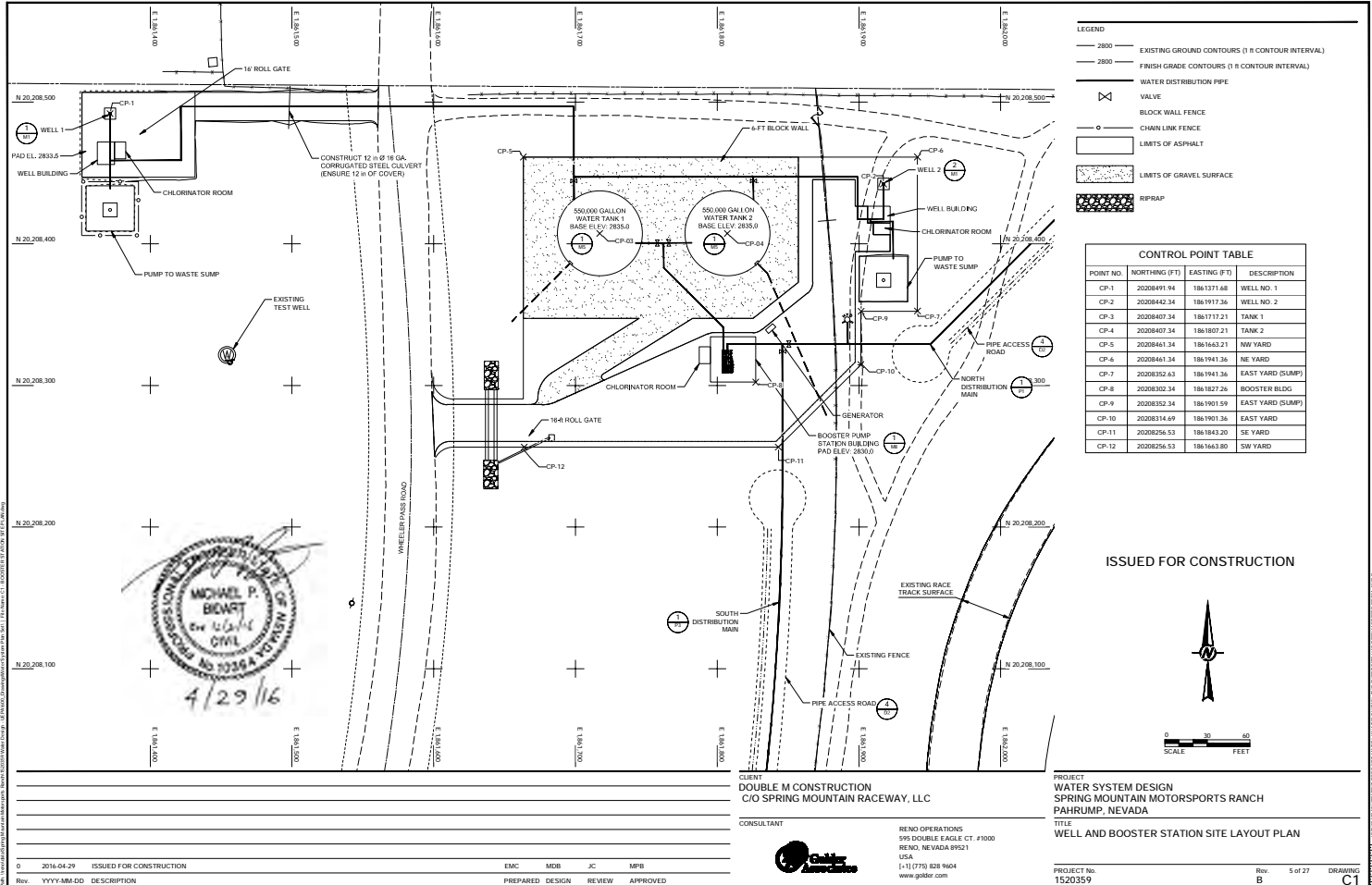

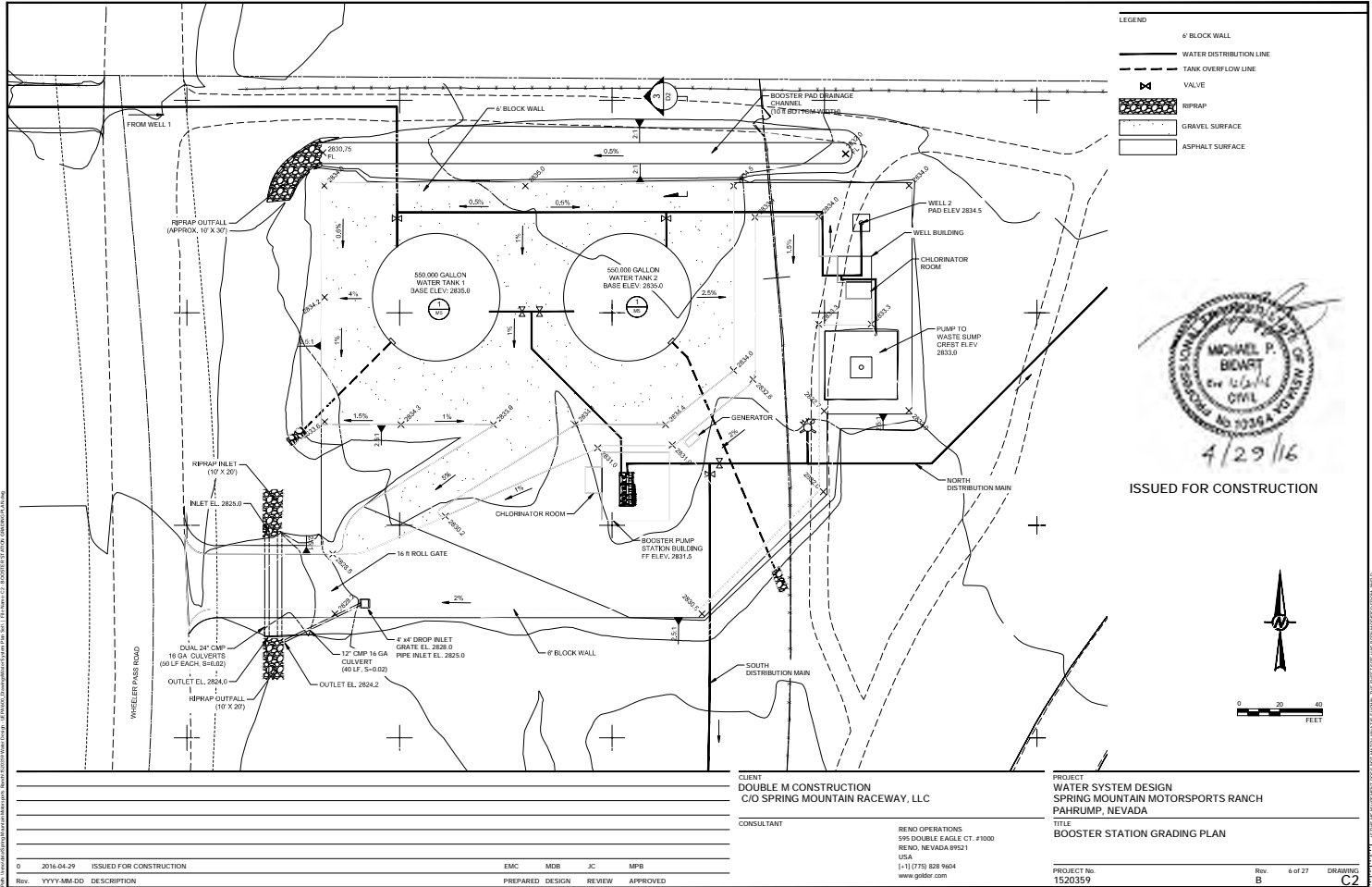

0	2016-04-29	ISSUED FOR CONSTRUCTION	EMC	MEB	JC	MPB
Rev	YYYY-MM-DD	DESCRIPTION	PREPARED	DESIGN	REVIEW	APPROVED

CLIENT
DOUBLE M CONSTRUCTION
 C/O SPRING MOUNTAIN RACEWAY, LLC

CONSULTANT
 RENO OPERATIONS
 595 DOUBLE EAGLE CT. #1000
 RENO, NEVADA 89521
 USA
 1-11(775) 828 9604
 www.gbdor.com

PROJECT
WATER SYSTEM DESIGN
 SPRING MOUNTAIN MOTORSPORTS RANCH
 PAHRUMP, NEVADA

TITLE
BOOSTER STATION GRADING PLAN

PROJECT No.
 1520359

Rev
 B

6 of 27
 DRAWING
C2

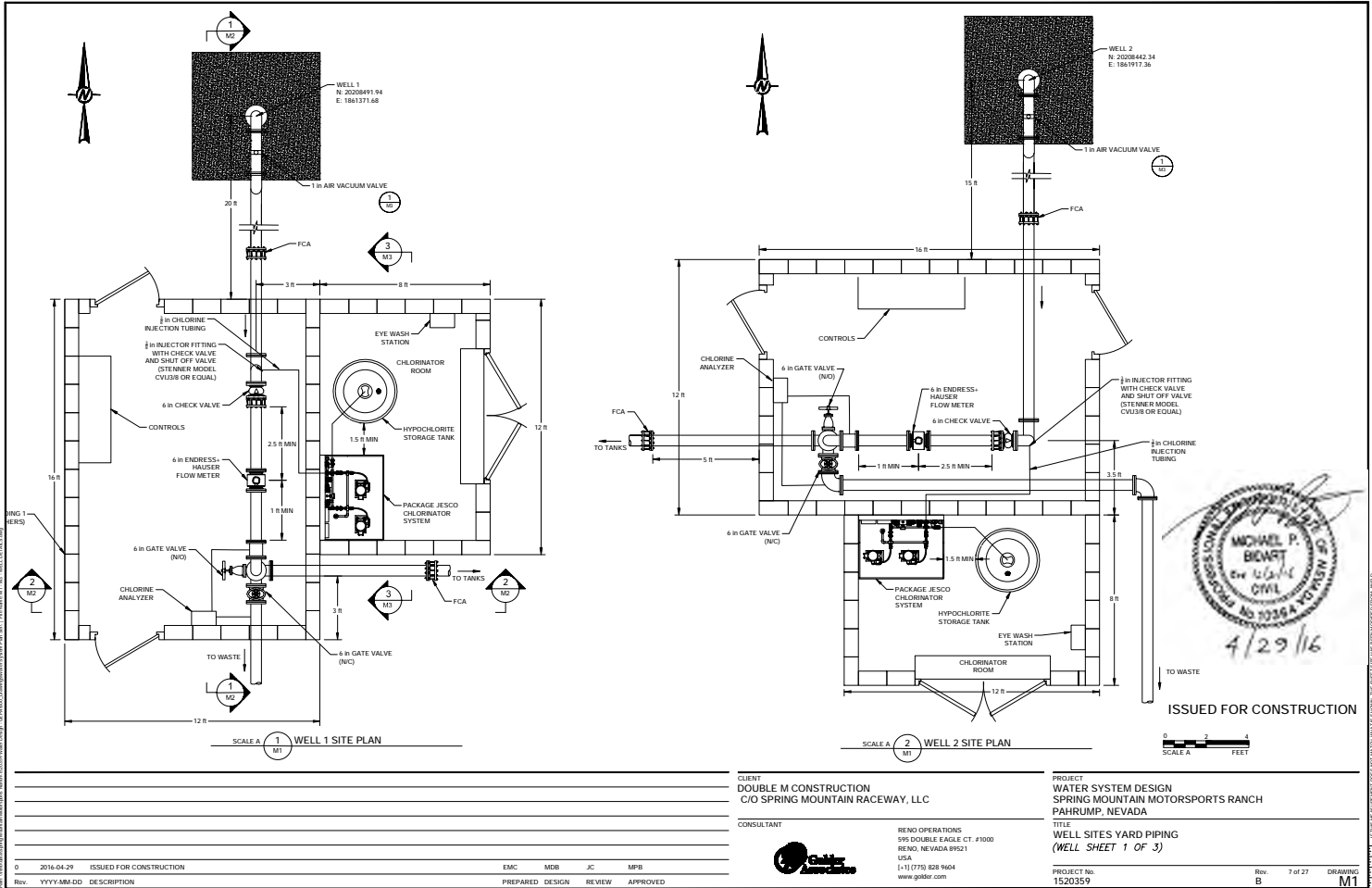

NOTES:
 1. TYPICAL SECTIONS FOR WELL BUILDINGS ARE CUT FOR WELL 1 AND APPLY CONCEPTUALLY TO WELL 2.

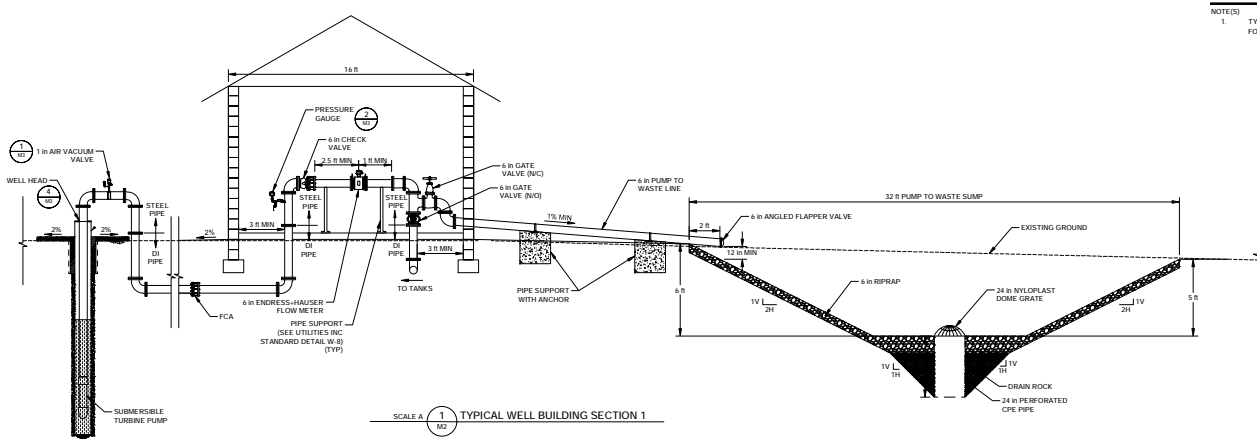

SCALE A 1 TYPICAL WELL BUILDING SECTION 1

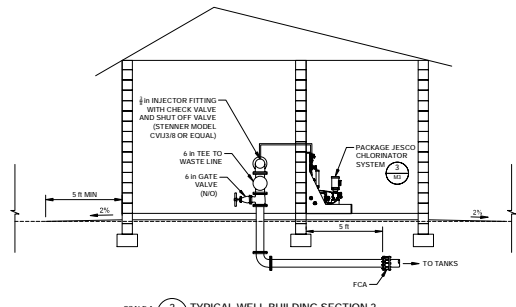

SCALE A 2 TYPICAL WELL BUILDING SECTION 2



ISSUED FOR CONSTRUCTION



0	2016-04-29	ISSUED FOR CONSTRUCTION	EMC	MEB	JC	MPB
Rev	YYYY-MM-DD	DESCRIPTION	PREPARED	DESIGN	REVIEW	APPROVED

CLIENT
 DOUBLE M CONSTRUCTION
 C/O SPRING MOUNTAIN RACEWAY, LLC

CONSULTANT
 RENO OPERATIONS
 595 DOUBLE EAGLE CT. #1000
 RENO, NEVADA 89521
 USA
 1-11(775) 828-9404
 www.gator.com

PROJECT
 WATER SYSTEM DESIGN
 SPRING MOUNTAIN MOTORSPORTS RANCH
 PAHRUMP, NEVADA

TITLE
 WELL HOUSE SECTION
 (WELL SHEET 2 OF 3)

PROJECT No.
 1520359

Rev
 B

8 of 27
 DRAWING
 M2

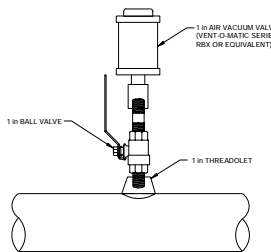

SCALE NTS 1 AIR VACUUM VALVE DETAIL

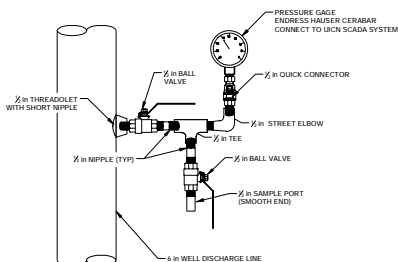

SCALE NTS 2 PRESSURE GAUGE AND SAMPLE PORT

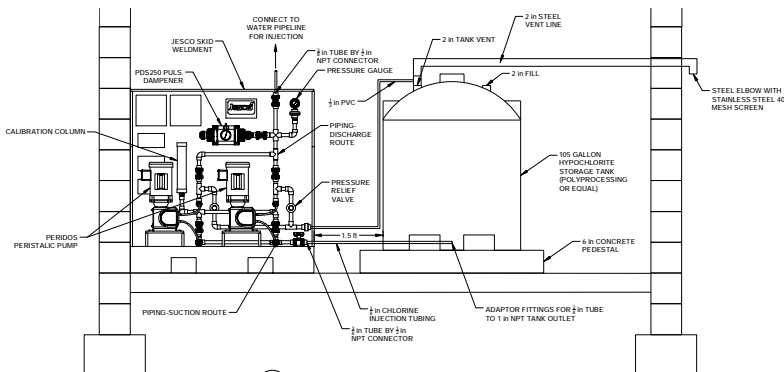

SCALE NTS 3 PACKAGE JESCO CHLORINATOR SYSTEM DETAIL

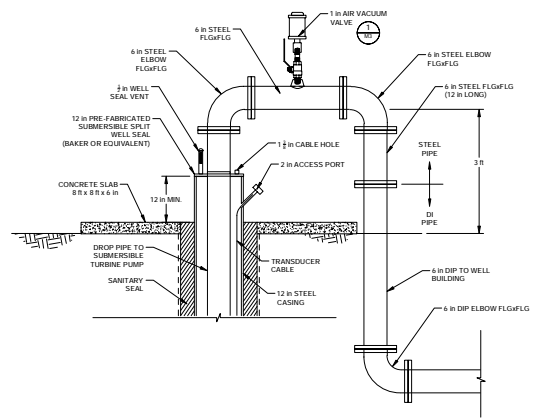

SCALE NTS 4 WELL HEAD DETAIL



ISSUED FOR CONSTRUCTION

0	2016-04-29	ISSUED FOR CONSTRUCTION	EMC	MEB	JC	MPB
Rev	YYYY-MM-DD	DESCRIPTION	PREPARED	DESIGN	REVIEW	APPROVED

CLIENT
DOUBLE M CONSTRUCTION
C/O SPRING MOUNTAIN RACEWAY, LLC

CONSULTANT



RENO OPERATIONS
595 DOUBLE EAGLE CT. #1000
RENO, NEVADA 89521
USA
1-11(775) 828 9404
www.gidtor.com

PROJECT
WATER SYSTEM DESIGN
SPRING MOUNTAIN MOTORSPORTS RANCH
PAHRUMP, NEVADA

TITLE
WELL DETAILS
(WELL SHEET 3 OF 3)

PROJECT No.
1520359

Rev
B

9 of 27 DRAWING
M3

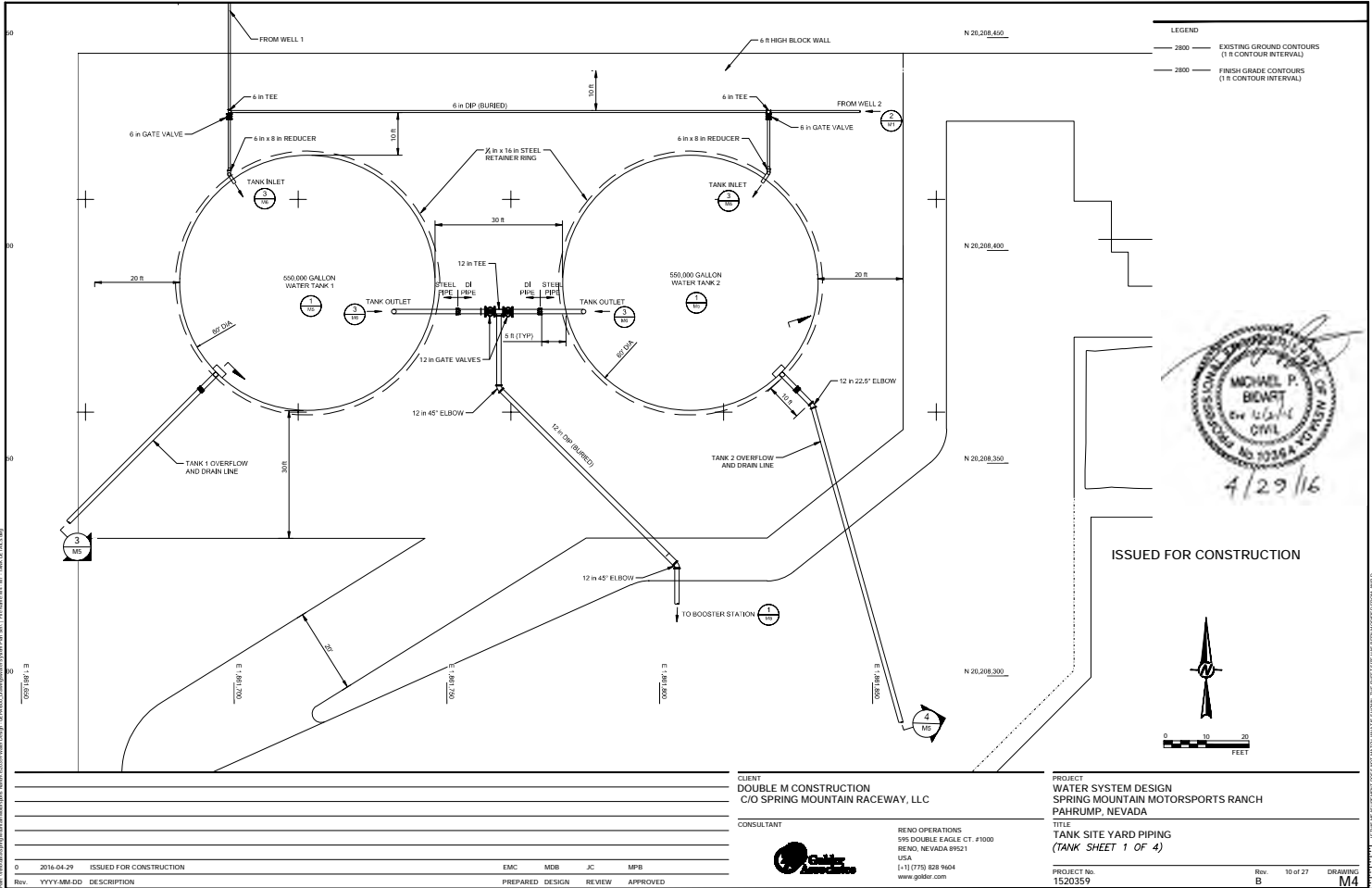

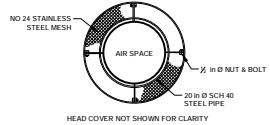

PLAN

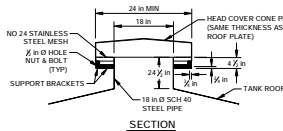

SECTION

SCALE NTS 1 M6

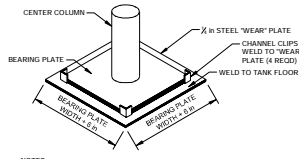

- NOTES
1. PRE COAT UNDERSIDE OF BEARING PLATE AND TOP SIDE OF "WEAR" PLATE PRIOR TO FINAL ERECTION.
 2. WELDING OF BEARING PLATE TO "WEAR" PLATE WILL NOT BE ALLOWED.
 3. FLOOR PLATE LAPS WILL NOT BE PERMITTED UNDER WEAR PLATE.

SCALE NTS 2 M6

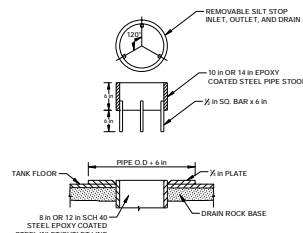

- NOTES
1. CONTRACTOR TO REPAIR EPOXY COATING ON INLET/OUTLET PIPE DUE TO DAMAGE FROM WELDING.
 2. AFTER WELDING PIPE TO TANK BOTTOM, GRIND THE WELD FLUSH TO PROVIDE A SUITABLE SEAT FOR SILT STOP.

SCALE NTS 3 M6

- NOTES
1. CONTRACTOR SHALL SUBMIT SHOP DRAWINGS INDICATING STEEL THICKNESS, WELDS, LAYOUT AND STRUCTURAL CALCULATIONS PURSUANT WITH AWWA D100 FOR ENGINEER REVIEW.

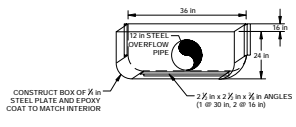

SCALE NTS 4 M6

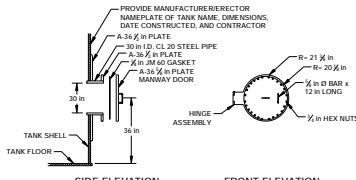

SIDE ELEVATION FRONT ELEVATION

SCALE NTS 5 M6

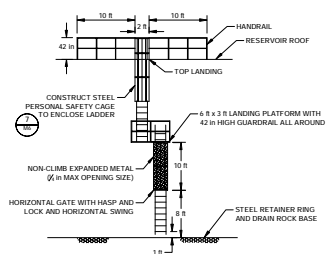

SCALE NTS 6 M6

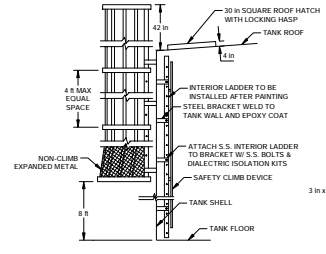

ELEVATION PLAN

SCALE NTS 7 1/2 M6



ISSUED FOR CONSTRUCTION

CLIENT DOUBLE M CONSTRUCTION C/O SPRING MOUNTAIN RACEWAY, LLC				PROJECT WATER SYSTEM DESIGN SPRING MOUNTAIN MOTORSPORTS RANCH PAHRUMP, NEVADA			
CONSULTANT 				TITLE TANK DETAILS (TANK SHEET 3 OF 4)			
RENO OPERATIONS 595 DOUBLE EAGLE CT. #1000 RENO, NEVADA 89521 USA 1-11(775) 528-9404 www.golder.com				PROJECT No. 1520359			
0	2016-04-29	ISSUED FOR CONSTRUCTION	EMC	MEB	JC	MPB	
Rev.	YYYY-MM-DD	DESCRIPTION	PREPARED	DESIGN	REVIEW	APPROVED	

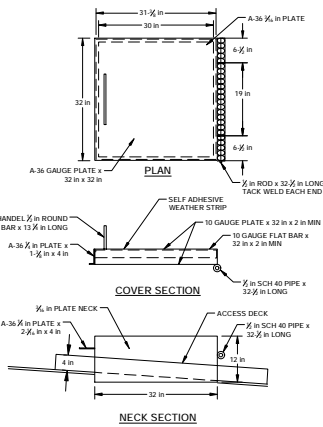

SCALE NTS 1
ROOF ENTRY HATCH DETAIL

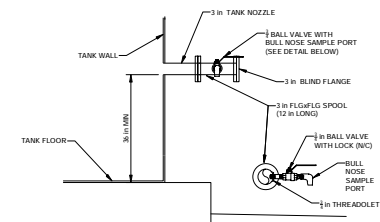

SCALE NTS 6
SAMPLE PORT DETAIL

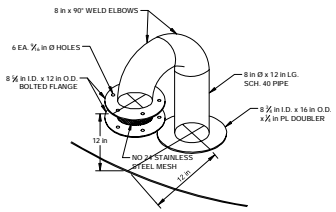

SCALE NTS 2
8 in Ø DOUBLE 90° ELBOW ROOF J-VENT DETAIL

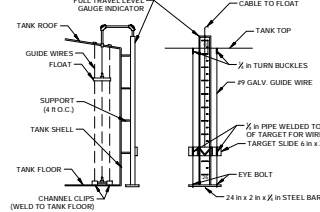

SCALE NTS 3
LIQUID LEVEL INDICATOR DETAIL

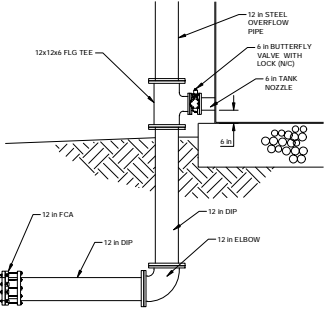

SCALE NTS 5
TANK DRAIN VALVE DETAIL

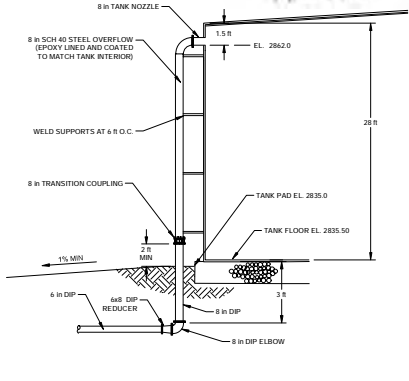

SCALE NTS 4
TANK INLET PIPING DETAIL

NOTES
1. CONTRACTOR SHALL SUBMIT SHOP DRAWINGS INDICATING STEEL THICKNESS, WELDS, LAYOUT AND STRUCTURAL CALCULATIONS PURSUANT WITH AWWA D100 FOR ENGINEER REVIEW.

ISSUED FOR CONSTRUCTION



0	2016-04-29	ISSUED FOR CONSTRUCTION	EMC	MEB	JC	MPB
Rev	YYYY-MM-DD	DESCRIPTION	PREPARED	DESIGN	REVIEW	APPROVED

CLIENT DOUBLE M CONSTRUCTION C/O SPRING MOUNTAIN RACEWAY, LLC	PROJECT WATER SYSTEM DESIGN SPRING MOUNTAIN MOTORSPORTS RANCH PAHRUMP, NEVADA
CONSULTANT 	TITLE TANK DETAILS (TANK SHEET 4 OF 4)
RENO OPERATIONS 595 DOUBLE EAGLE CT. #1000 RENO, NEVADA 89521 USA 1-11(775) 828 9404 www.golder.com	PROJECT No. 1520359
	Rev: 13 of 27 DRAWING: B M7

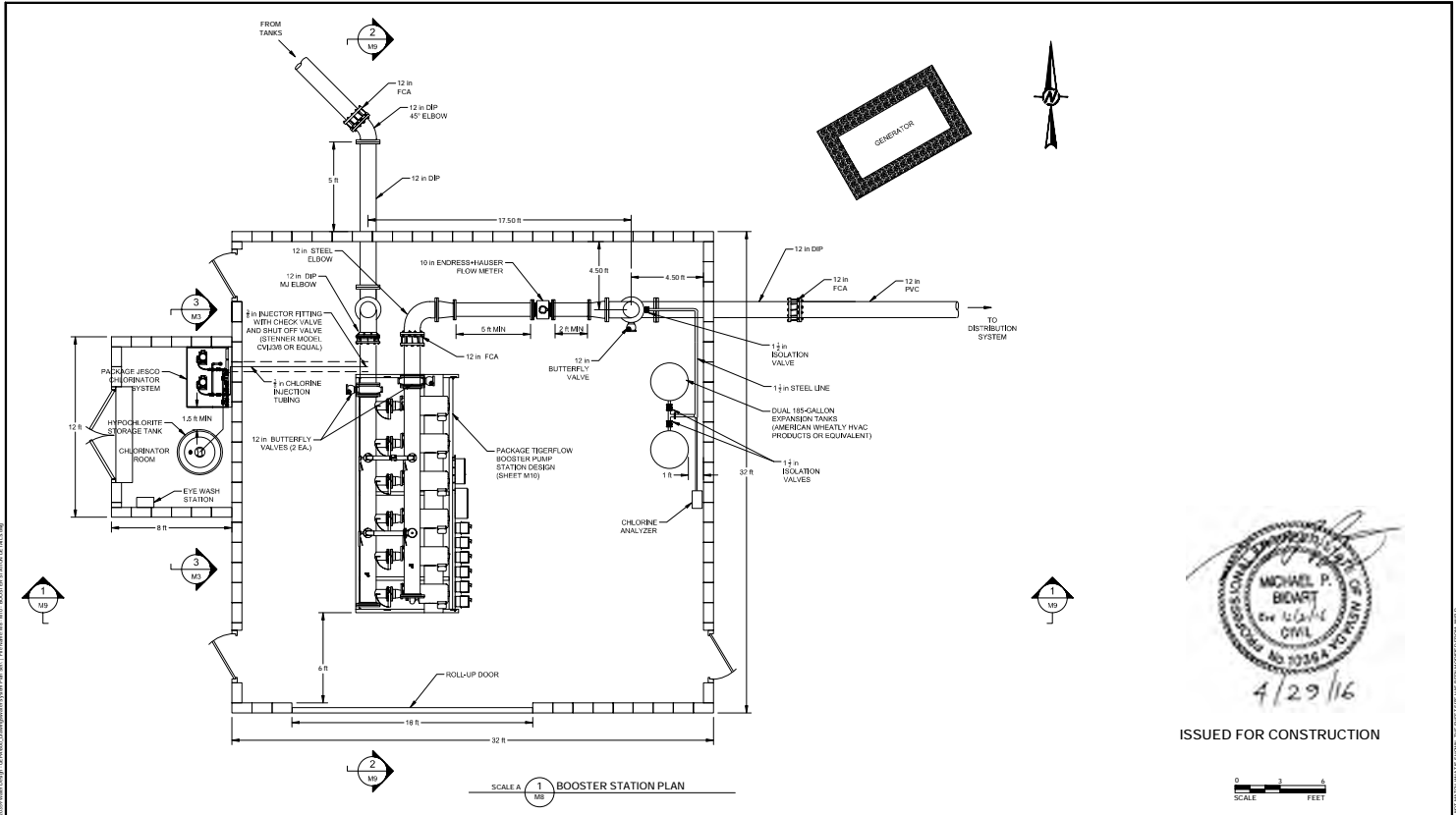

ISSUED FOR CONSTRUCTION



CLIENT DOUBLE M CONSTRUCTION C/O SPRING MOUNTAIN RACEWAY, LLC				PROJECT WATER SYSTEM DESIGN SPRING MOUNTAIN MOTORSPORTS RANCH PAHRUMP, NEVADA			
CONSULTANT 				TITLE BOOSTER STATION PLAN (BOOSTER SHEET 1 OF 3)			
RENO OPERATIONS 595 DOUBLE EAGLE CT. #1000 RENO, NEVADA 89521 USA 1-11(775) 828 9604 www.golder.com				PROJECT No. 1520359			
0 2016-04-29 ISSUED FOR CONSTRUCTION				EAC MCB JC MPB			
Rev. VVVV-MM-DD DESCRIPTION				PREPARED DESIGN REVIEW APPROVED			

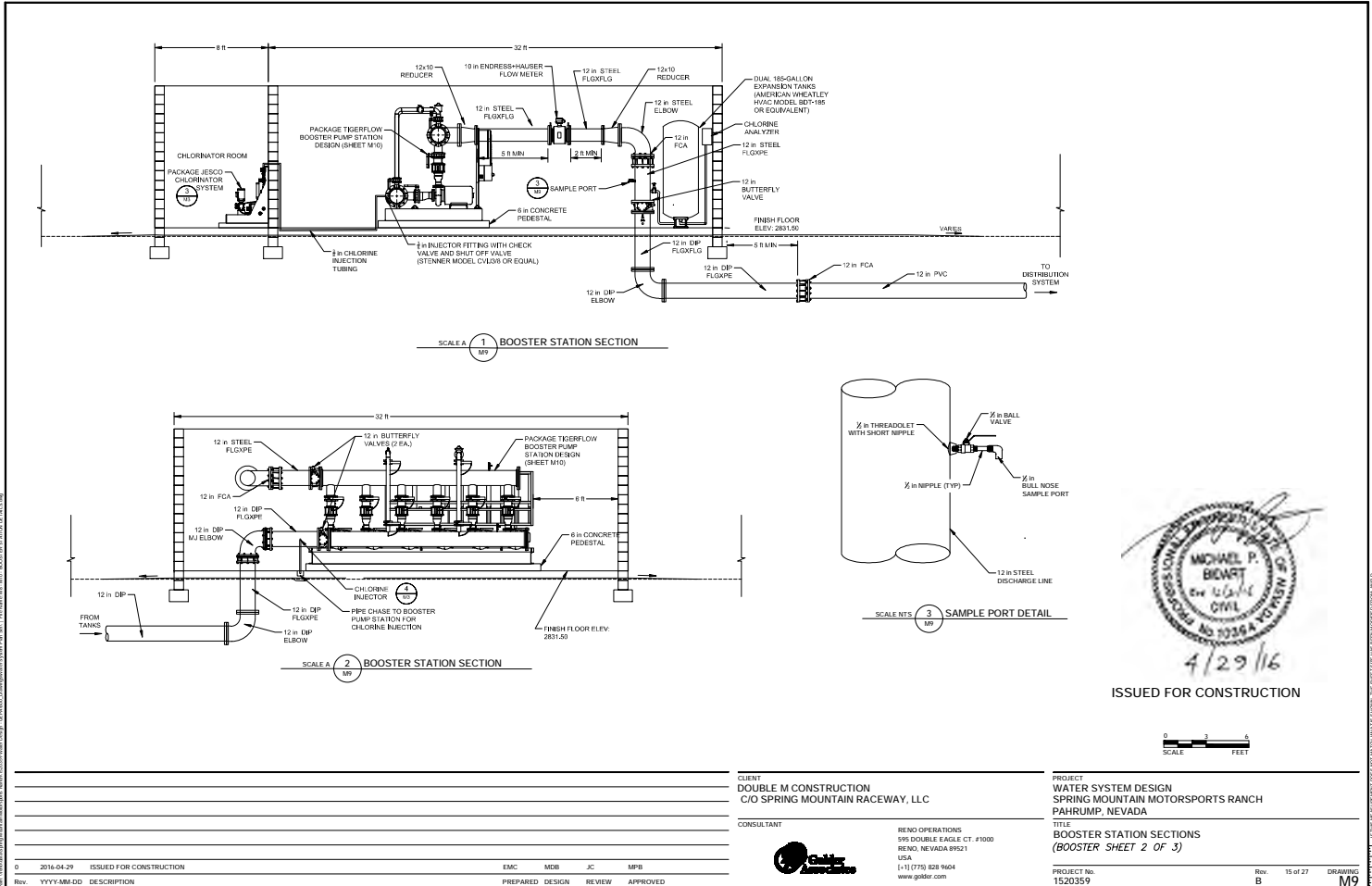

4/29/16
ISSUED FOR CONSTRUCTION



CLIENT DOUBLE M CONSTRUCTION C/O SPRING MOUNTAIN RACEWAY, LLC				PROJECT WATER SYSTEM DESIGN SPRING MOUNTAIN MOTORSPORTS RANCH PAHRUMP, NEVADA			
CONSULTANT  GOLDER ASSOCIATES				TITLE BOOSTER STATION SECTIONS (BOOSTER SHEET 2 OF 3)			
RENO OPERATIONS 595 DOUBLE EAGLE CT. #1000 RENO, NEVADA 89521 USA 1-11(775) 828 9404 www.golder.com				PROJECT No. 1520359			
0 2016-04-29 ISSUED FOR CONSTRUCTION				EAC MCB JC MPB PREPARED DESIGN REVIEW APPROVED			
Rev. VVVV-MM-DD DESCRIPTION				Rev. 15 of 27 DRAWING B			

ISSUED FOR CONSTRUCTION

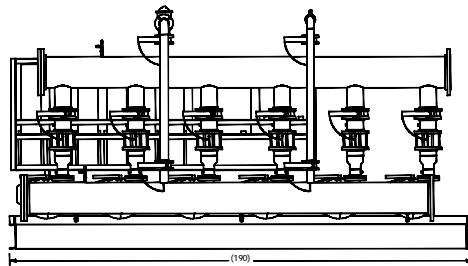
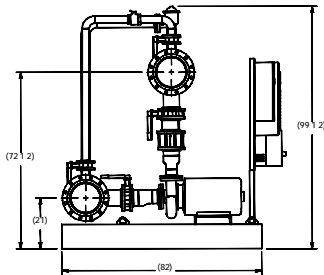
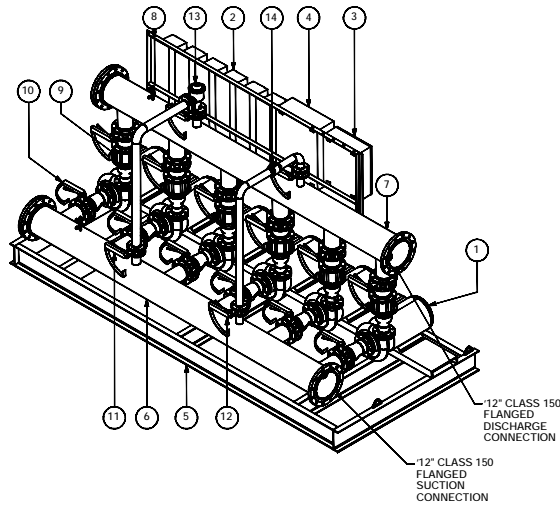
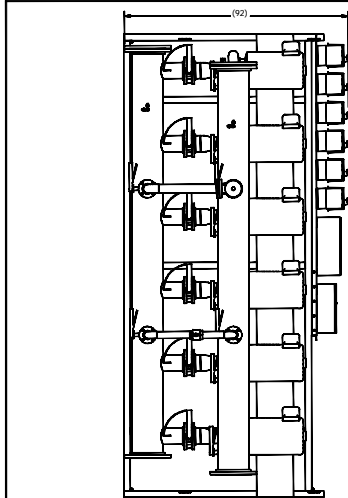

NOTE: SALES DRAWING FOR REFERENCE ONLY, SYSTEM AND DIMENSIONS MAY VARY

SYM	QTY	DESCRIPTION
14	1	51 1/2" FLOW BYPASS WITH FLOW CONTROL VALVE
13	1	7" BENTIS MODEL 1152 SURGE ANTICIPATING RELIEF VALVE
12	2	2 1/2" BRAY 31H LUG STYLE B/V LEVER HANDLE
11	2	2" BRAY 31H LUG STYLE B/V LEVER HANDLE
10	12	2" BRAY 31H LUG STYLE B/V LEVER HANDLE
9	4	1/2" VAL 125 200 WATER SELECT CR. STAINLESS TRM - 4"
8	1	ASSEMBLY PANEL STAND
7	1	ASSEMBLY HEADER 12" (DISCHARGE)
6	1	ASSEMBLY HEADER 12" (SUCTION)
5	1	ASSEMBLY SKID
4	1	LUG PANEL 24 X 30 X 10
3	1	24 X20 W/ NEMA 4 1/2 E-Series Enclosure w/ HMI TOUCH SCREEN PAD
2	2	WPD 400 RPM 500 NEMA 1 20 HP
1	2	WPD 400 RPM 500 NEMA 1 20 HP
		GOOP PREMIUM MOTORS

BILL OF MATERIALS	
MANUFACTURING DRAWING	DATE: 7-4-2015
MS	DATE:
PRODUCTION	DATE:
PROJECT FILE	15-48380-SD
SPRING MOUNTAIN MOTOR SPORTS	
OUTLINE	
PAGE	1
NTS	0

T:\Projects\2015\15-48380\15-48380-SD.dwg (15-48380-SD.dwg) - 15-48380-SD.dwg (15-48380-SD.dwg) - 15-48380-SD.dwg (15-48380-SD.dwg)

<p>CLIENT DOUBLE M CONSTRUCTION C/O SPRING MOUNTAIN RACEWAY, LLC</p> <p>CONSULTANT</p> <p>RENO OPERATIONS 595 DOUBLE EAGLE CT. #1000 RENO, NEVADA 89521 USA 1-11(775) 828 9604 www.gdbr.com</p>	<p>PROJECT WATER SYSTEM DESIGN SPRING MOUNTAIN MOTORSPORTS RANCH PAHRUMP, NEVADA</p> <p>TITLE BOOSTER STATION DETAILS (BOOSTER SHEET 3 OF 3)</p> <p>PROJECT No. 1520359</p> <p>Rev. B 16 of 27 DRAWING M10</p>
--	--

REV	DESCRIPTION	EAC	MDE	JC	MPB
0	2016-04-29 ISSUED FOR CONSTRUCTION				
1	2016-04-29 ISSUED FOR CONSTRUCTION				

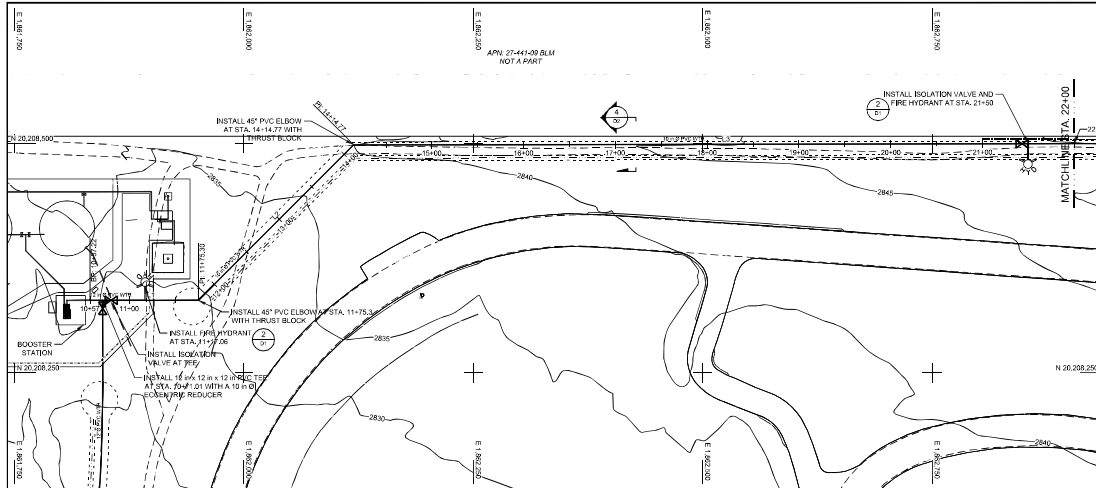

LEGEND

- EXISTING GROUND
- SECTION LINES
- EXISTING ROAD
- EXISTING ROW
- PROPOSED PAVED ROAD
- PROPOSED PIPE ACCESS ROAD
- PROPOSED WATER MAIN
- WATER SYSTEM BY IMPULSE ENGINEERING REF. RESIDENTIAL IMPROVEMENT PLANS (MAY 8, 2013)
- ISOLATION VALVE
- FIRE HYDRANT

NOTES

- CONTRACTOR TO NOTIFY ALL UTILITY COMPANIES AS WELL AS THE CITY OF PAHRUMP AND NYE COUNTY'S MAINTENANCE DEPARTMENT PRIOR TO CONSTRUCTION.
- EXISTING UTILITIES ARE APPROXIMATE. CONTRACTOR TO POT HOLE AND VERIFY LOCATIONS AND DEPTHS PRIOR TO CONSTRUCTION.
- ALL EFFORTS MUST BE MADE TO RETURN ANY DISTURBED AREAS BACK TO THEIR NATIVE CONDITION UPON THE COMPLETION OF WORK.
- MINIMUM REQUIRED COVER OVER THE WATER MAIN MUST BE 40 INCHES. IF FINISH GRADE IS PROVIDED BEFORE CONSTRUCTION OF THE WATER MAIN, THE MINIMUM COVER DISTANCE SHALL BE 42 INCHES.
- ALL WATER MAINS, TANKS, AND FITTINGS SHALL BE DISINFECTED PER AWWA C651 PRIOR TO DISTRIBUTION OF POTABLE WATER.
- ALL WATER MAIN, PRESSURE TANKS, AND FITTINGS SHALL BE PRESSURE TESTING PER AWWA C600 (DUCTILE IRON) AND C605 (PVC) PRIOR TO DISTRIBUTION OF POTABLE WATER.
- INSTALL WATER LINES WITH CONTINUOUS POSITIVE SLOPE. ADVISE ENGINEER OF ANY LOCALIZED HIGH POINTS OR LOW POINTS.
- CONSTRUCT FIRE HYDRANTS ADJACENT TO THE WATER MAINS AT EVERY 1000 FT LENGTH OF PIPE PLACED PER UNCL STANDARD DETAIL W-11.
- INSTALL AN ISOLATION VALVE ON THE WATER MAIN AT EVERY 1000 FT LENGTH OF PIPE PLACED.
- WATER MAIN SHALL BE CONSTRUCTED USING CLASS 235 DR 18 PVC PIPE AND CONFORM WITH AWWA STANDARD C900.



LINE TABLE:

LINE #	LENGTH (FT)	BEARING	START POINT (N. E)	END POINT (N. E)
L1	118.1	N80° 00' 00.00\"E	(200205205.1, 1861932.3)	(200205226.1, 1861956.3)
L2	238.5	N45° 00' 00.00\"E	(200205226.1, 1861956.3)	(200204985.5, 1862119.7)
L3	1785.0	N65° 54' 25.45\"E	(200204985.5, 1862119.7)	(200205011.4, 18620899.7)

SCALE 1 NORTH WATER DISTRIBUTION MAIN PLAN: STATIONS 10+00 TO 22+00

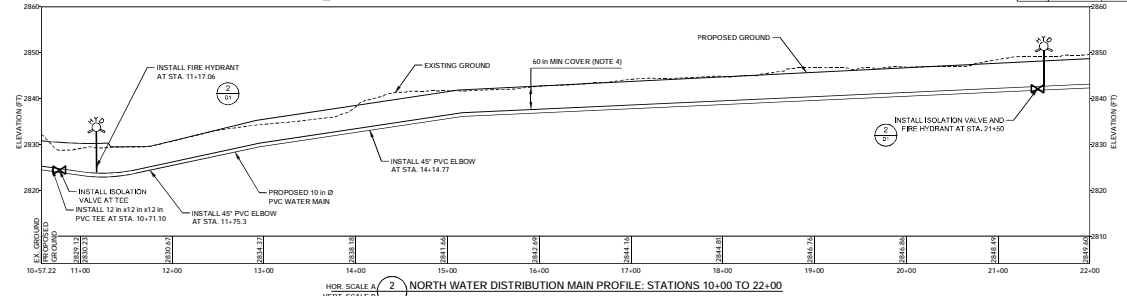

ISSUED FOR CONSTRUCTION

0 50 100 0 25 50
SCALE A FEET SCALE B FEET

SCALE 2 NORTH WATER DISTRIBUTION MAIN PROFILE: STATIONS 10+00 TO 22+00

<p>CLIENT DOUBLE M CONSTRUCTION C/O SPRING MOUNTAIN RACEWAY, LLC</p> <p>CONSULTANT Golder Associates</p>	<p>PROJECT WATER SYSTEM DESIGN SPRING MOUNTAIN MOTORSPORTS RANCH PAHRUMP, NEVADA</p> <p>TITLE NORTH DISTRIBUTION MAIN PLAN AND PROFILE (1 OF 2)</p>	<p>RENO OPERATIONS 595 DOUBLE EAGLE CT. #1000 RENO, NEVADA 89521 USA [+1] (775) 828 9404 www.golder.com</p>	<p>PROJECT No. 1520359</p> <p>Rev. 16 of 27 DRAWING B P1</p>
---	---	---	--

3	2016-04-29	ISSUED FOR CONSTRUCTION
Rev.	YYYY-MM-DD	DESCRIPTION

EMC	MDR	JC	MPB
PREPARED	DESIGN	REVIEW	APPROVED

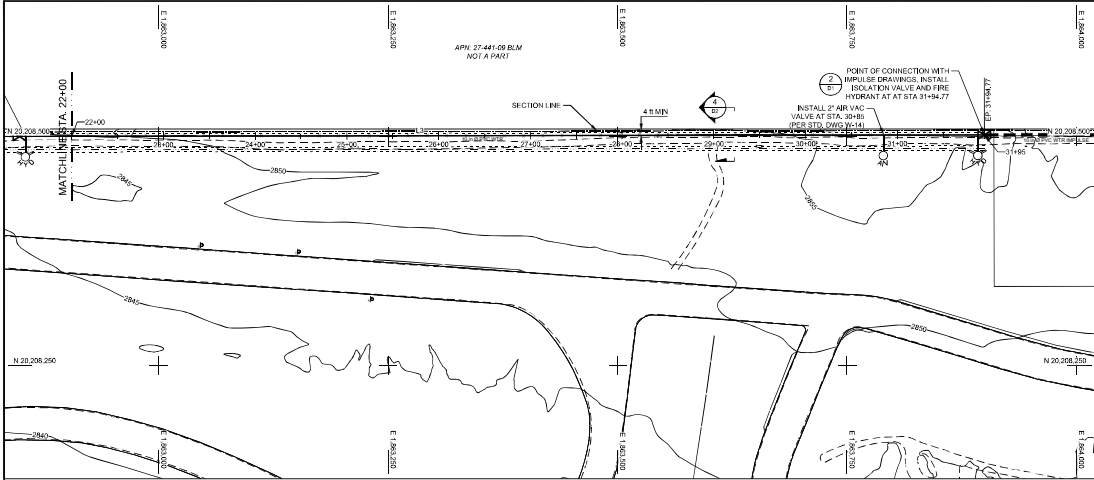

LEGEND

- EXISTING GROUND
- SECTION LINES
- EXISTING ROW
- EXISTING ROAD
- PROPOSED PAVED ROAD
- PROPOSED PIPE ACCESS ROAD
- PROPOSED WATER MAIN
- WATER SYSTEM BY IMPULSE ENGINEERING REF. RESIDENTIAL IMPROVEMENT PLANS (RAY 8, 2013)
- ISOLATION VALVE
- FIRE HYDRANT

NOTES

1. CONTRACTOR TO NOTIFY ALL UTILITY COMPANIES AS WELL AS THE CITY OF PAHRUMP AND WYE COUNTY'S MAINTENANCE DEPARTMENT PRIOR TO CONSTRUCTION.
2. EXISTING UTILITIES ARE APPROXIMATE. CONTRACTOR TO POT HOLE AND VERIFY LOCATIONS AND DEPTHS PRIOR TO CONSTRUCTION.
3. ALL EFFORTS MUST BE MADE TO RETURN ANY DISTURBED AREAS BACK TO THEIR NATIVE CONDITION UPON THE COMPLETION OF WORK.
4. MINIMUM REQUIRED COVER OVER THE WATER MAIN MUST BE 40 INCHES. IF FINISH GRADE IS PROVIDED BEFORE CONSTRUCTION OF THE WATER MAIN, THE MINIMUM COVER DISTANCE SHALL BE 42 INCHES.
5. ALL WATER MAINS, TANKS, AND FITTINGS SHALL BE DISINFECTED PER AWWA C651 PRIOR TO DISTRIBUTION OF POTABLE WATER.
6. ALL WATER MAIN, PRESSURE TANKS, AND FITTINGS SHALL BE PRESSURE TESTING PER AWWA C600 (DUCTILE IRON AND CAST IRON) PRIOR TO DISTRIBUTION OF POTABLE WATER.
7. INSTALL WATER LINES WITH CONTINUOUS POSITIVE SLOPE. ADVISE ENGINEER OF ANY LOCALIZED HIGH POINTS OR LOW POINTS.
8. CONSTRUCT FIRE HYDRANTS ADJACENT TO THE WATER MAINS AT EVERY 1000 FT LENGTH OF PIPE PLACED PER UICN STANDARD DETAIL W-11.
9. INSTALL AN ISOLATION VALVE ON THE WATER MAIN AT EVERY 1000 FT LENGTH OF PIPE PLACED.
10. WATER MAIN SHALL BE CONSTRUCTED USING CLASS 235 DR 18 PVC PIPE AND CONFORM WITH AWWA STANDARD C900.

LINE TABLE:

LINE #	LENGTH (FT)	BEARING	START POINT (N. E.)	END POINT (N. E.)
L3	1780.0	N85°54'25.45\"/>		

SCALE A 1 NORTH WATER DISTRIBUTION MAIN PLAN: STATIONS 22+00 TO 31+94.77

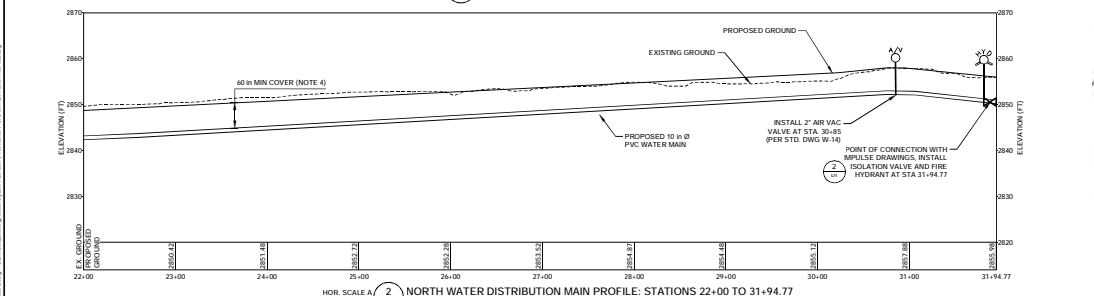

HOR. SCALE A 2 VERT. SCALE B 2 NORTH WATER DISTRIBUTION MAIN PROFILE: STATIONS 22+00 TO 31+94.77

ISSUED FOR CONSTRUCTION

<p>CLIENT DOUBLE M CONSTRUCTION C/O SPRING MOUNTAIN RACEWAY, LLC</p> <p>CONSULTANT</p> <p>RENO OPERATIONS 595 DOUBBLE EAGLE CT. #1000 RENO, NEVADA 89521 USA 1-775-753-828 9604 www.gbdw.com</p>	<p>PROJECT WATER SYSTEM DESIGN SPRING MOUNTAIN MOTORSPORTS RANCH PAHRUMP, NEVADA</p> <p>TITLE NORTH DISTRIBUTION MAIN PLAN AND PROFILE (2 OF 2)</p> <p>PROJECT No. 1520359</p> <p>Rev. 17 of 27 B</p> <p>DRAWING P2</p>
--	---

NO.	DATE	DESCRIPTION	PREPARED	DESIGN	REVIEW	APPROVED
0	2016-04-29	ISSUED FOR CONSTRUCTION	EMC	MSB	JC	MPB
Rev.	YYYY-MM-DD	DESCRIPTION	PREPARED	DESIGN	REVIEW	APPROVED

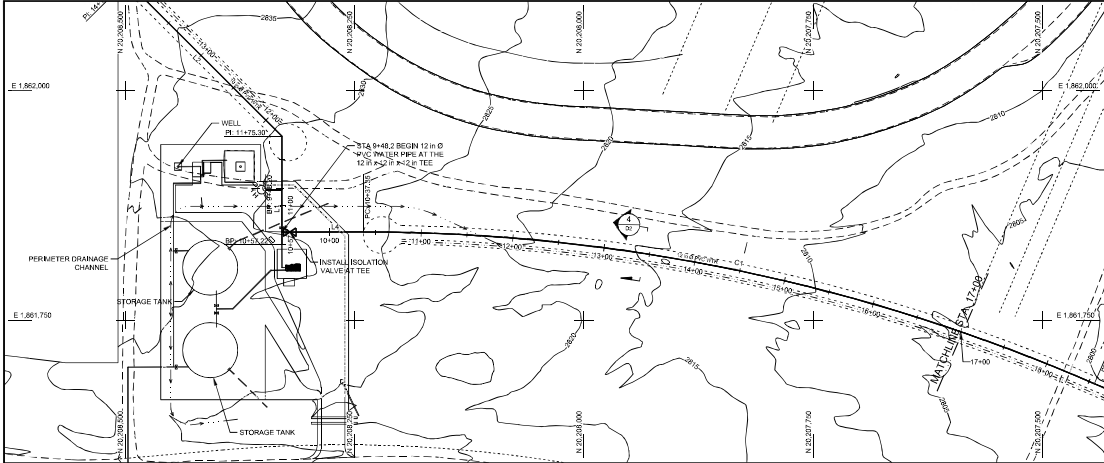

SCALE A 1 SOUTH WATER DISTRIBUTION MAIN PLAN: STATIONS 10+00 TO 17+00

LEGEND

- EXISTING GROUND
- SECTION LINES
- EXISTING ROW
- EXISTING ROAD
- PROPOSED PAVED ROAD
- PROPOSED PIPE ACCESS ROAD
- PROPOSED WATER MAIN
- PROPOSED WATER MAIN
- WATER SYSTEM BY: IMPULSE ENGINEERING REF. RESIDENTIAL IMPROVEMENT PLANS (MAY 8, 2013)
- ISOLATION VALVE
- FIRE HYDRANT

NOTES

1. CONTRACTOR TO NOTIFY ALL UTILITY COMPANIES AS WELL AS THE CITY OF PAHRUMP AND WYE COUNTY'S MAINTENANCE DEPARTMENT PRIOR TO CONSTRUCTION.
2. EXISTING UTILITIES ARE APPROXIMATE. CONTRACTOR TO POT HOLE AND VERIFY LOCATIONS AND DEPTHS PRIOR TO CONSTRUCTION.
3. ALL EFFORTS MUST BE MADE TO RETURN ANY DISTURBED AREAS BACK TO THEIR NATIVE CONDITION UPON THE COMPLETION OF WORK.
4. MINIMUM REQUIRED COVER OVER THE WATER MAIN MUST BE 40 INCHES. IF FINISH GRADE IS PROVIDED BEFORE CONSTRUCTION OF THE WATER MAIN, THE MINIMUM COVER DISTANCE SHALL BE 42 INCHES.
5. ALL WATER MAINS, TANKS, AND FITTINGS SHALL BE DISINFECTED PER AWWA C651 PRIOR TO DISTRIBUTION OF POTABLE WATER.
6. ALL WATER MAIN, PRESSURE TANKS, AND FITTINGS SHALL BE PRESSURE TESTING PER AWWA C600 (DUCTILE IRON AND CAST IRON) PRIOR TO DISTRIBUTION OF POTABLE WATER.
7. INSTALL WATER MAINS WITH CONTINUOUS POSITIVE SLOPE. ADVISE ENGINEER OF ANY LOCALIZED HIGH POINTS OR LOW POINTS.
8. CONSTRUCT FIRE HYDRANTS ADJACENT TO THE WATER MAINS AT EVERY 1000 FT LENGTH OF PIPE PLACED PER IUCN STANDARD DETAIL W-11.
9. INSTALL AN ISOLATION VALVE ON THE WATER MAIN AT EVERY 1000 FT LENGTH OF PIPE PLACED.
10. WATER MAIN SHALL BE CONSTRUCTED USING CLASS 235 DR 18 PVC PIPE AND CONFORM WITH AWWA STANDARD C900.

LINE TABLE:

LINE #	LENGTH (FT)	BEARING	START POINT (N. E.)	END POINT (N. E.)
L4	68.2	S0° 09' 23.83"E	(20208240.0, 1861946.1)	(20208240.0, 1861946.1)

CURVE TABLE:

CURVE #	RADIUS (FT)	LENGTH (FT)	START POINT (N. E.)	END POINT (N. E.)
C1	2000.0	819.0	(20208240.0, 1861946.1)	(20207443.7, 1861980.8)

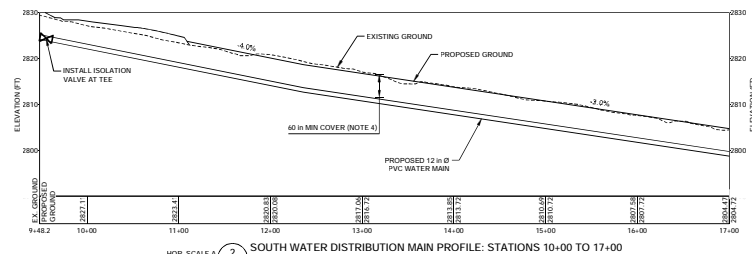

SCALE B 2 SOUTH WATER DISTRIBUTION MAIN PROFILE: STATIONS 10+00 TO 17+00



ISSUED FOR CONSTRUCTION



	<p>CLIENT DOUBLE M CONSTRUCTION C/O SPRING MOUNTAIN RACEWAY, LLC</p>	<p>PROJECT WATER SYSTEM DESIGN SPRING MOUNTAIN MOTORSPORTS RANCH PAHRUMP, NEVADA</p>
	<p>CONSULTANT</p> <p>Golden Association</p> <p>RENO OPERATIONS 595 DOUBLE EAGLE CT, #1000 RENO, NEVADA 89521 USA 1-775-753-8298 www.gdbw.com</p>	<p>TITLE SOUTH DISTRIBUTION MAIN PLAN AND PROFILE (1 OF 6)</p>
<p>0 2016-04-29 ISSUED FOR CONSTRUCTION</p> <p>Rev: YYYY-MM-DD DESCRIPTION</p>	<p>EMC MCB JC MPB</p> <p>PREPARED DESIGN REVIEW APPROVED</p>	<p>PROJECT No. 1520359</p> <p>Rev: 18 of 27 DRAWING P3</p>

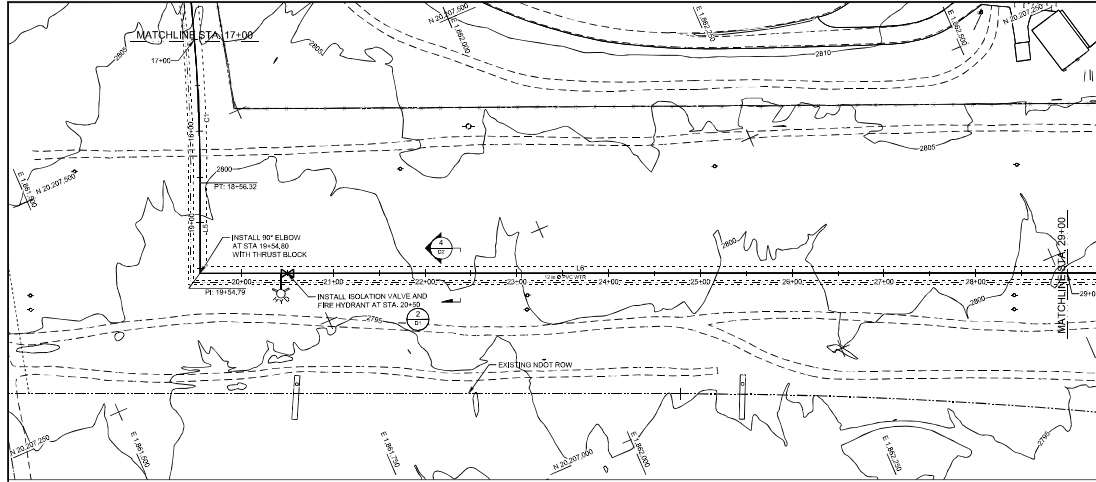

SCALE A 1 SOUTH WATER DISTRIBUTION MAIN PLAN: STATIONS 17+00 TO 29+00

LEGEND

- EXISTING GROUND
- SECTION LINES
- EXISTING ROW
- EXISTING ROAD
- PROPOSED PAVED ROAD
- PROPOSED PIPE ACCESS ROAD
- PROPOSED WATER MAIN
- 12" PVC WATER MAIN
- WATER SYSTEM BY IMPULSE ENGINEERING
REF. RESIDENTIAL IMPROVEMENT PLANS (MAY 8, 2013)
- ISOLATION VALVE
- FIRE HYDRANT

4/29/16

- NOTES**
1. CONTRACTOR TO NOTIFY ALL UTILITY COMPANIES AS WELL AS THE CITY OF PAHRUMP AND NVE COUNTY'S MAINTENANCE DEPARTMENT PRIOR TO CONSTRUCTION.
 2. EXISTING UTILITIES ARE APPROXIMATE. CONTRACTOR TO POT HOLE AND VERIFY LOCATIONS AND DEPTHS PRIOR TO CONSTRUCTION.
 3. ALL EFFORTS MUST BE MADE TO RETURN ANY DISTURBED AREAS BACK TO THEIR NATIVE CONDITION UPON THE COMPLETION OF WORK.
 4. MINIMUM REQUIRED COVER OVER THE WATER MAIN MUST BE 40 INCHES. IF FINISH GRADE IS PROVIDED BEFORE CONSTRUCTION OF THE WATER MAIN, THE MINIMUM COVER DISTANCE SHALL BE 42 INCHES.
 5. ALL WATER MAINS, TANKS, AND FITTINGS SHALL BE DISINFECTED PER AWWA C651 PRIOR TO DISTRIBUTION OF POTABLE WATER.
 6. ALL WATER MAIN, PRESSURE TANKS, AND FITTINGS SHALL BE PRESSURE TESTING PER AWWA C600 (DUCTILE IRON) AND C600 (PVC) PRIOR TO DISTRIBUTION OF POTABLE WATER.
 7. INSTALL WATER LINES WITH CONTINUOUS POSITIVE SLOPE. ADVISE ENGINEER OF ANY LOCALIZED HIGH POINTS OR LOW POINTS.
 8. CONSTRUCT FIRE HYDRANTS ADJACENT TO THE WATER MAINS AT EVERY 1000 FT LENGTH OF PIPE PLACED PER UNCL STANDARD DETAIL W-11.
 9. INSTALL AN ISOLATION VALVE ON THE WATER MAIN AT EVERY 1000 FT LENGTH OF PIPE PLACED.
 10. WATER MAIN SHALL BE CONSTRUCTED USING CLASS 235 OR 18 PVC PIPE AND CONFORM WITH AWWA STANDARD C900.

LINE TABLE:

LINE #	LENGTH (FT)	BEARING	START POINT (N, E)	END POINT (N, E)
L5	98.0	S23° 27' 18.24"W	(20207443.7, 1861680.8)	(20207353.4, 1861641.6)
L6	1367.3	S86° 52' 41.76"E	(20207353.4, 1861641.6)	(20206669.2, 1862895.9)

CURVE TABLE:

CURVE #	RADIUS (FT)	LENGTH (FT)	START POINT (N, E)	END POINT (N, E)
C6	2000.0	819.0	(20206240.0, 1861646.1)	(20207443.7, 1861680.8)

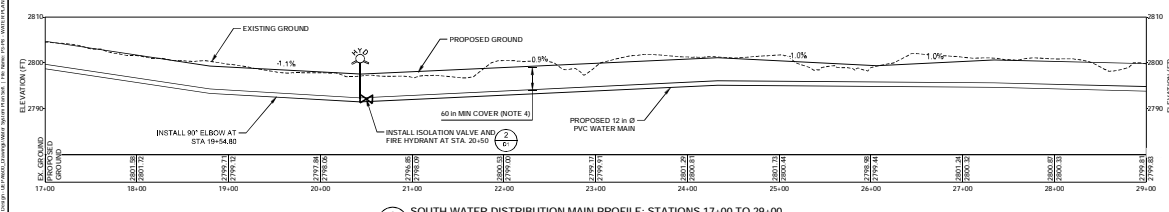

VERT. SCALE B 2 SOUTH WATER DISTRIBUTION MAIN PROFILE: STATIONS 17+00 TO 29+00

ISSUED FOR CONSTRUCTION

SCALE A 0 50 100 FEET
 SCALE B 0 10 20 FEET

<p>CLIENT DOUBLE M CONSTRUCTION C/O SPRING MOUNTAIN RACEWAY, LLC</p> <p>CONSULTANT</p> <p>RENO OPERATIONS 595 DOUBLE EAGLE CT. #1000 RENO, NEVADA 89521 USA [+1] (775) 828 9404 www.golder.com</p>	<p>PROJECT WATER SYSTEM DESIGN SPRING MOUNTAIN MOTORSPORTS RANCH PAHRUMP, NEVADA</p> <p>TITLE SOUTH DISTRIBUTION MAIN PLAN AND PROFILE (2 OF 6)</p> <p>PROJECT No. 1520359</p> <p>Rev. 19 of 27 DRAWING B P4</p>
<p>0 2016-04-29 ISSUED FOR CONSTRUCTION</p> <p>Rev. YYYY-MM-DD DESCRIPTION</p> <p>EMC MDB JC MPB PREPARED DESIGN REVIEW APPROVED</p>	<p>0 2016-04-29 ISSUED FOR CONSTRUCTION</p> <p>Rev. YYYY-MM-DD DESCRIPTION</p> <p>EMC MDB JC MPB PREPARED DESIGN REVIEW APPROVED</p>

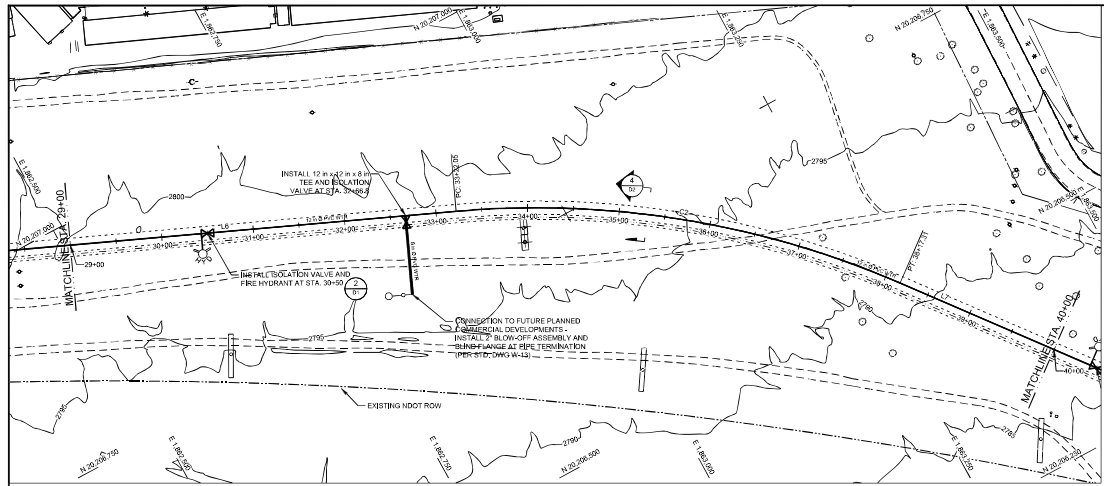

SCALE 1 SOUTH WATER DISTRIBUTION SYSTEM PLAN: STATIONS 29+00 TO 40+00

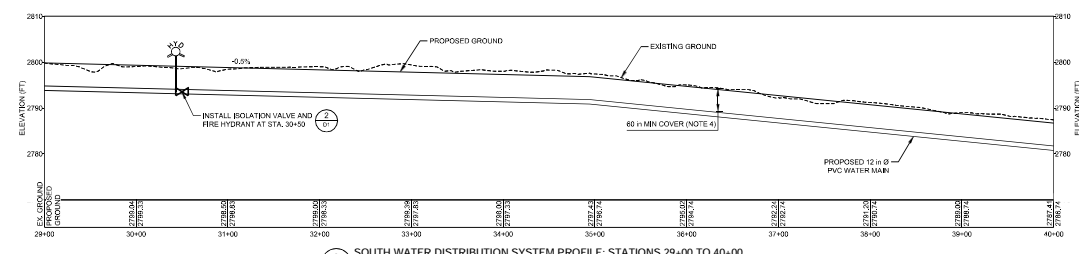

HOR. SCALE A VERT. SCALE B SOUTH WATER DISTRIBUTION SYSTEM PROFILE: STATIONS 29+00 TO 40+00

LEGEND

- 2770 --- EXISTING GROUND
- SECTION LINES
- EXISTING ROW
- EXISTING ROAD
- PROPOSED PAVED ROAD
- PROPOSED PIPE ACCESS ROAD
- PROPOSED WATER MAIN
- WATER SYSTEM BY IMPULSE ENGINEERING REF. RESIDENTIAL IMPROVEMENT PLANS (MAY 8, 2013)
- ⊗ ISOLATION VALVE
- ⊗ FIRE HYDRANT

- NOTES**
1. CONTRACTOR TO NOTIFY ALL UTILITY COMPANIES AS WELL AS THE CITY OF PAHRUMP AND WYE COUNTY'S MAINTENANCE DEPARTMENT PRIOR TO CONSTRUCTION.
 2. EXISTING UTILITIES ARE APPROXIMATE. CONTRACTOR TO POT HOLE AND VERIFY LOCATIONS AND DEPTHS PRIOR TO CONSTRUCTION.
 3. ALL EFFORTS MUST BE MADE TO RETURN ANY DISTURBED AREAS BACK TO THEIR NATIVE CONDITION UPON THE COMPLETION OF WORK.
 4. MINIMUM REQUIRED COVER OVER THE WATER MAIN MUST BE 60 INCHES. IF FINISH GRADE IS PROVIDED BEFORE CONSTRUCTION OF THE WATER MAIN, THE MINIMUM COVER DISTANCE SHALL BE 42 INCHES.
 5. ALL WATER MAINS, TANKS, AND FITTINGS SHALL BE PRESSURE TESTING PER AWWA C600 (DUCTILE IRON) AND C605 (PVC) PRIOR TO DISTRIBUTION OF POTABLE WATER.
 6. ALL WATER MAINS, TANKS, AND FITTINGS SHALL BE PRESSURE TESTING PER AWWA C600 (DUCTILE IRON) AND C605 (PVC) PRIOR TO DISTRIBUTION OF POTABLE WATER.
 7. INSTALL WATER LINES WITH CONTINUOUS POSITIVE SLOPE. ADVISE ENGINEER OF ANY LOCALIZED HIGH POINTS OR LOW POINTS.
 8. CONSTRUCT FIRE HYDRANTS ADJACENT TO THE WATER MAINS AT EVERY 1000 FT LENGTH OF PIPE PLACED PER UNCLN STANDARD DETAIL W-11.
 9. INSTALL AN ISOLATION VALVE ON THE WATER MAIN AT EVERY 1000 FT LENGTH OF PIPE PLACED.
 10. WATER MAIN SHALL BE CONSTRUCTED USING CLASS 235 DR 18 PVC PIPE AND CONFORM WITH AWWA STANDARD C900.

LINE TABLE:

LINE #	LENGTH (FT)	BEARING	START POINT (N. E.)	END POINT (N. E.)
L6	1387.3	S89° 32' 41.70"E	(2020735.4, 1801641.5)	(2020882.2, 1802395.5)
L7	1202.1	S18° 19' 37.30"E	(2020859.8, 1802084.1)	(2020548.6, 1804082.2)

CURVE TABLE:

CURVE #	RADIUS (FT)	LENGTH (FT)	START POINT (N. E.)	END POINT (N. E.)
C2	1900.0	465.3	(2020689.2, 1802895.8)	(2020609.8, 1803284.1)

ISSUED FOR CONSTRUCTION

<p>CLIENT DOUBLE M CONSTRUCTION C/O SPRING MOUNTAIN MOTORSPORTS RANCH</p> <p>CONSULTANT </p> <p>RENO OPERATIONS 595 DOUBLE EAGLE CT. #1000 RENO, NEVADA 89521 USA [+1] (775) 829 9404 www.golden.com</p>	<p>PROJECT WATER SYSTEM DESIGN SPRING MOUNTAIN MOTORSPORTS RANCH PAHRUMP, NEVADA</p> <p>TITLE SOUTH DISTRIBUTION MAIN PLAN AND PROFILE (3 OF 6)</p> <p>PROJECT No. 1520359</p> <p>Rev. 20 of 27 DRAWING B P5</p>
<p>0 2016-04-29 ISSUED FOR CONSTRUCTION</p> <p>Rev. YYYY-MM-DD DESCRIPTION</p>	<p>EMC MDR JC MPB</p> <p>PREPARED DESIGN REVIEW APPROVED</p>

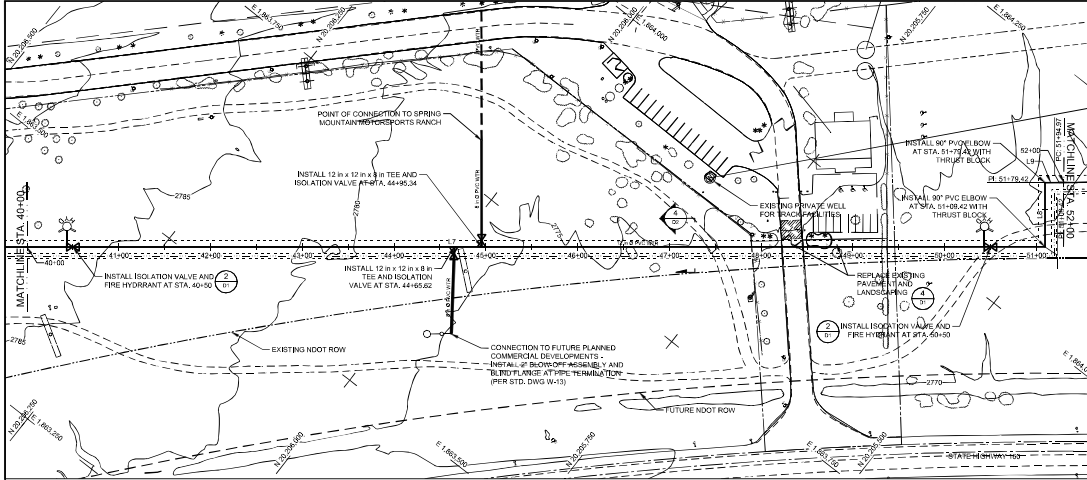

LEGEND

- EXISTING GROUND
- SECTION LINES
- EXISTING ROW
- EXISTING ROAD
- PROPOSED PAVED ROAD
- PROPOSED PIPE ACCESS ROAD
- PROPOSED WATER MAIN
- PROPOSED 12" PVC WATER MAIN
- PROPOSED 12" IRON WATER MAIN
- WATER SYSTEM BY IMPULSE ENGINEERING REF. RESIDENTIAL IMPROVEMENT PLANS (MAY 8, 2013)
- ISOLATION VALVE
- FIRE HYDRANT

NOTES

1. CONTRACTOR TO NOTIFY ALL UTILITY COMPANIES AS WELL AS THE CITY OF PAHRUMP AND WYE COUNTY'S MAINTENANCE DEPARTMENT PRIOR TO CONSTRUCTION.
2. EXISTING UTILITIES ARE APPROXIMATE. CONTRACTOR TO FOOT HOLE AND VERIFY LOCATIONS AND DEPTHS PRIOR TO CONSTRUCTION.
3. ALL EFFORTS MUST BE MADE TO RETURN ANY DISTURBED AREAS BACK TO THEIR NATIVE CONDITION UPON THE COMPLETION OF WORK.
4. MINIMUM REQUIRED COVER OVER THE WATER MAIN MUST BE 40 INCHES. IF FINISH GRADE IS PROVIDED BEFORE CONSTRUCTION OF THE WATER MAIN, THE MINIMUM COVER DISTANCE SHALL BE 42 INCHES.
5. ALL WATER MAINS, TANKS, AND FITTINGS SHALL BE DISINFECTED PER AWWA C651 PRIOR TO DISTRIBUTION OF POTABLE WATER.
6. ALL WATER MAIN, PRESSURE TANKS, AND FITTINGS SHALL BE PRESSURE TESTING PER AWWA C600 (DUCTILE IRON AND CAST IRON) PRIOR TO DISTRIBUTION OF POTABLE WATER.
7. INSTALL WATER LINES WITH CONTINUOUS POSITIVE SLOPE. ADVISE ENGINEER OF ANY LOCALIZED HIGH POINTS OR LOW POINTS.
8. CONSTRUCT FIRE HYDRANTS ADJACENT TO THE WATER MAINS AT EVERY 1000 FT LENGTH OF PIPE PLACED PER IUCN STANDARD DETAIL W-11.
9. INSTALL AN ISOLATION VALVE ON THE WATER MAIN AT EVERY 1000 FT LENGTH OF PIPE PLACED.
10. WATER MAIN SHALL BE CONSTRUCTED USING CLASS 200 DR 18 PVC PIPE AND CONFORM WITH AWWA STANDARD C900.

LINE TABLE:

LINE #	LENGTH (FT)	BEARING	START POINT (N, E)	END POINT (N, E)
L7	1262.1	S38° 10' 07.30"E	(20205599.8, 1863284.1)	(20205495.9, 1864082.6)
L8	70.0	N51° 49' 52.70"E	(20205495.9, 1864082.6)	(20205537.2, 1864137.6)
L9	15.6	S38° 10' 07.30"E	(20205537.2, 1864137.6)	(20205524.9, 1864147.1)

SCALE A 1 SOUTH WATER DISTRIBUTION SYSTEM PLAN: STATIONS 40+00 TO 52+00

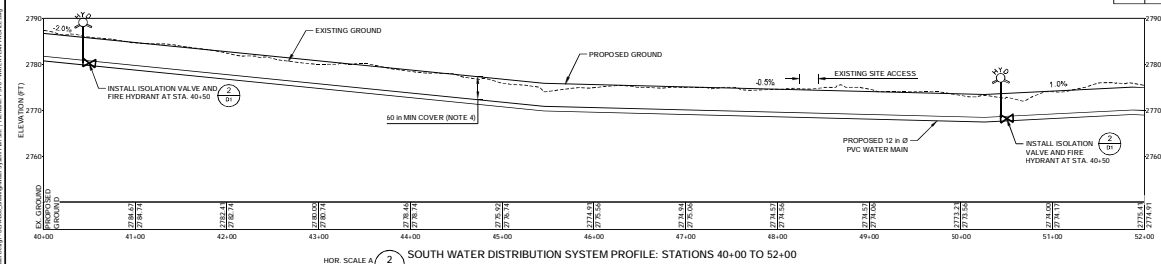

SCALE A 2 SOUTH WATER DISTRIBUTION SYSTEM PROFILE: STATIONS 40+00 TO 52+00

ISSUED FOR CONSTRUCTION

CLIENT DOUBLE M CONSTRUCTION C/O SPRING MOUNTAIN RACEWAY, LLC			PROJECT WATER SYSTEM DESIGN SPRING MOUNTAIN MOTORSPORTS RANCH PAHRUMP, NEVADA		
CONSULTANT 			TITLE SOUTH DISTRIBUTION MAIN PLAN AND PROFILE (4 OF 6)		
RENO OPERATIONS 595 DOUBLE EAGLE CT., #1000 RENO, NEVADA 89521 USA 1-775-752-9604 www.gdbor.com			PROJECT No. 1520359		
0 2016-04-29 ISSUED FOR CONSTRUCTION Rev: YYYY-MM-DD DESCRIPTION			Rev: 21 of 27 DRAWING: P6		

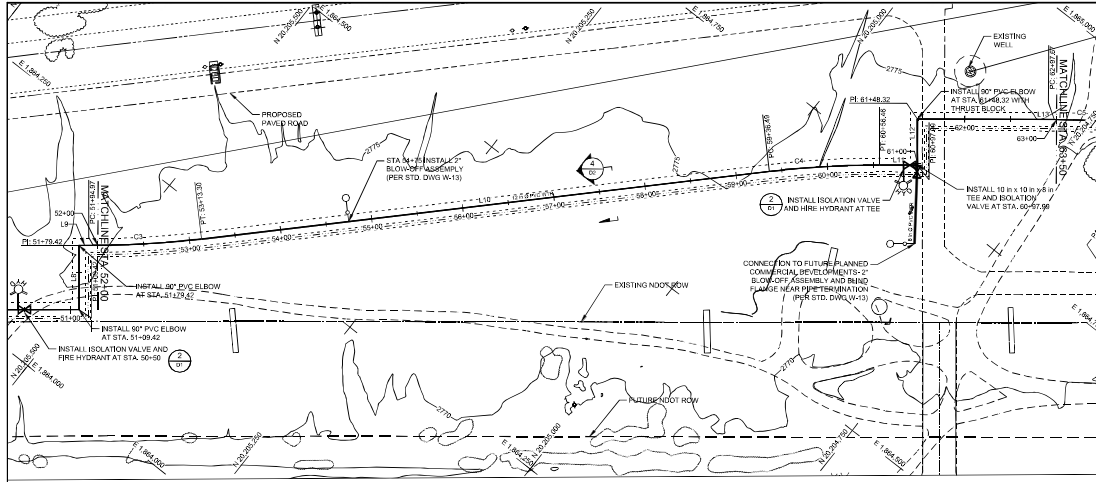

LEGEND

- EXISTING GROUND
- SECTION LINES
- EXISTING ROW
- EXISTING ROAD
- PROPOSED PAVED ROAD
- PROPOSED PIPE ACCESS ROAD
- WATER MAIN
- WATER SYSTEM BY IMPULSE ENGINEERING REF. RESIDENTIAL IMPROVEMENT PLANS (MAY 8, 2013)
- ISOLATION VALVE
- FIRE HYDRANT

NOTES

- CONTRACTOR TO NOTIFY ALL UTILITY COMPANIES AS WELL AS THE CITY OF PAHRUMP AND NYE COUNTY'S MAINTENANCE DEPARTMENT PRIOR TO CONSTRUCTION. EXISTING UTILITIES ARE APPROXIMATE. CONTRACTOR TO POT HOLE AND VERIFY LOCATIONS AND DEPTHS PRIOR TO CONSTRUCTION.
- ALL EFFORTS MUST BE MADE TO RETURN ANY DISTURBED AREAS BACK TO THEIR NATIVE CONDITION UPON THE COMPLETION OF WORK.
- WATER MAIN MUST BE PLACED A MINIMUM HORIZONTAL DISTANCE OF 10 FEET FROM SEWER LINES MEASURED FROM PIPE OUTER DIAMETERS TO PIPE OUTER DIAMETERS.
- WATER MAIN MUST BE PLACED A MINIMUM VERTICAL DISTANCE OF 18 INCHES FROM SEWER LINES MEASURED FROM PIPE OUTER DIAMETERS TO PIPE OUTER DIAMETERS.
- MINIMUM REQUIRED COVER OVER THE WATER MAIN MUST BE 40 INCHES. IF FINISH GRADE IS PROVIDED BEFORE CONSTRUCTION OF THE WATER MAIN, THE MINIMUM COVER DISTANCE SHALL BE 42 INCHES.
- ALL WATER MAINS, TANKS, AND FITTINGS SHALL BE DISINFECTED PER AWWA C651 PRIOR TO DISTRIBUTION OF POTABLE WATER.
- ALL WATER MAIN, PRESSURE TANKS, AND FITTINGS SHALL BE PRESSURE TESTING PER AWWA C600 (DUCTILE IRON AND C900 (PVC) PRIOR TO DISTRIBUTION OF POTABLE WATER.
- INSTALL WATER LINES WITH CONTINUOUS POSITIVE SLOPE. ADVISE ENGINEER OF ANY LOCALIZED HIGH POINTS OR LOW POINTS.
- CONSTRUCT FIRE HYDRANTS ADJACENT TO THE WATER MAINS AT EVERY 1000 FT LENGTH OF PIPE PLACED PER UIC STANDARD DETAIL W-11.
- INSTALL AN ISOLATION VALVE ON THE WATER MAIN AT EVERY 1000 FT LENGTH OF PIPE PLACED.
- WATER MAIN SHALL BE CONSTRUCTED USING CLASS 235 DR 18 PVC PIPE AND CONFORM WITH AWWA STANDARD C900.



SCALE A 1 SOUTH WATER DISTRIBUTION MAIN PLAN: STATIONS 52+00 TO 63+50

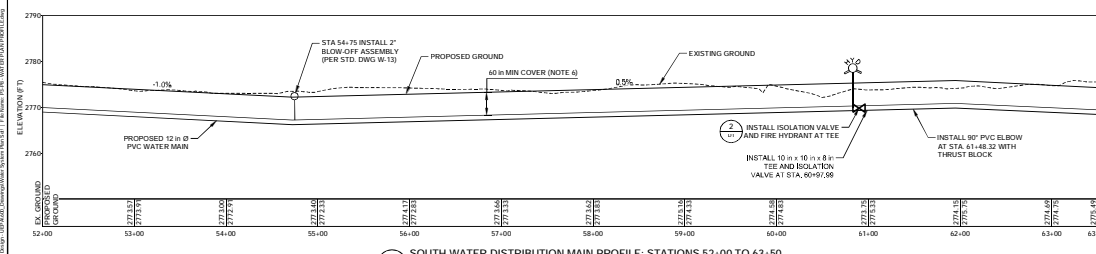

LINE TABLE:

LINE #	LENGTH (FT)	BEARING	START POINT (N. E.)	END POINT (N. E.)
L10	633.2	S44° 50' E	(2020438.5, 1864225.9)	(2020495.4, 1864995.0)
L11	41.5	S37° 04' 28.41\"/>		

CURVE TABLE:

CURVE #	RADIUS (FT)	LENGTH (FT)	START POINT (N. E.)	END POINT (N. E.)
C3	1000.0	118.3	(2020502.9, 1864147.2)	(20205436.5, 1864225.8)
C4	1000.0	120.0	(20204995.4, 1864665.9)	(20204905.6, 1864745.4)
C5	1000.0	63.0	(20204796.1, 1864892.4)	(20204735.2, 1864938.3)

ISSUED FOR CONSTRUCTION

SCALE A: 1" = 100' FEET
SCALE B: 1" = 20' FEET

CLIENT: DOUBLE M CONSTRUCTION
C/O SPRING MOUNTAIN RACEWAY, LLC

PROJECT: WATER SYSTEM DESIGN
SPRING MOUNTAIN MOTORSPORTS RANCH
PAHRUMP, NEVADA

CONSULTANT: GOLDER ASSOCIATES

RENO OPERATIONS: 595 DOUBLE EAGLE CT. #1000
RENO, NEVADA 89521
USA
[+1] (775) 828 9404
www.golder.com

TITLE: SOUTH DISTRIBUTION MAIN PLAN AND PROFILE (5 OF 6)

PROJECT No.: 1520359
Rev.: 22 of 27
DRAWING: P7

REVISIONS:

NO.	DATE	DESCRIPTION	EMC	MDR	JC	MPB
0	2016-04-29	ISSUED FOR CONSTRUCTION				
Rev.	YYYY-MM-DD	DESCRIPTION	PREPARED	DESIGN	REVIEW	APPROVED

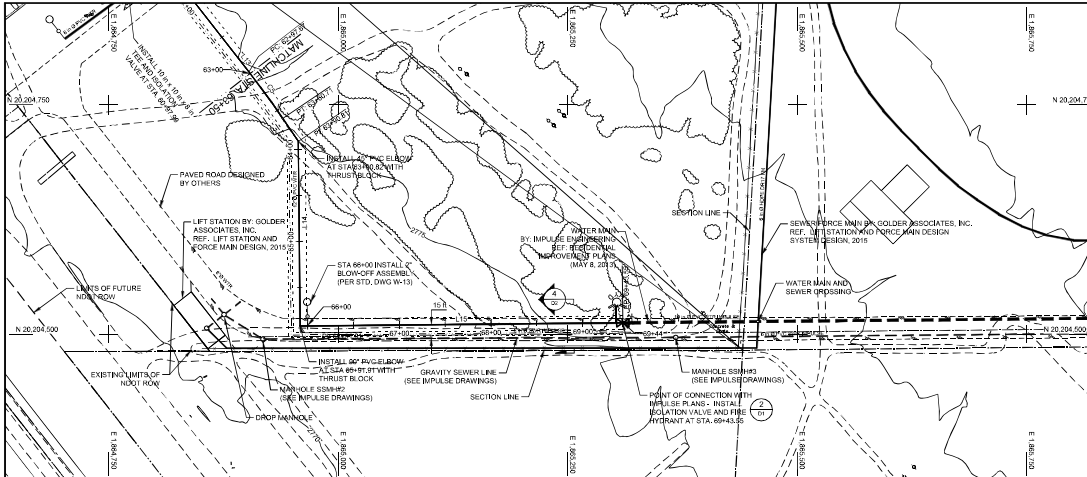

LEGEND

- EXISTING GROUND
- - - SECTION LINES
- EXISTING ROW
- EXISTING ROAD
- PROPOSED PAVED ROAD
- PROPOSED PIPE ACCESS ROAD
- PROPOSED WATER MAIN
- WATER SYSTEM BY IMPULSE ENGINEERING REF. RESIDENTIAL IMPROVEMENT PLANS (MAY 8, 2013)
- ISOLATION VALVE
- FIRE HYDRANT

- NOTES**
1. CONTRACTOR TO NOTIFY ALL UTILITY COMPANIES AS WELL AS THE CITY OF PAHRUMP AND WYE COUNTY'S MAINTENANCE DEPARTMENT PRIOR TO CONSTRUCTION.
 2. EXISTING UTILITIES ARE APPROXIMATE. CONTRACTOR TO POT HOLE AND VERIFY LOCATIONS AND DEPTHS PRIOR TO CONSTRUCTION.
 3. ALL EFFORTS MUST BE MADE TO RETURN ANY DISTURBED AREAS BACK TO THEIR NATIVE CONDITION UPON THE COMPLETION OF WORK.
 4. WATER MAIN MUST BE PLACED A MINIMUM HORIZONTAL DISTANCE OF 10 FEET FROM SEWER LINES MEASURED FROM PIPE OUTER DIAMETER TO PIPE OUTER DIAMETER.
 5. WATER MAIN MUST BE PLACED A MINIMUM VERTICAL DISTANCE OF 18 INCHES FROM SEWER LINES MEASURED FROM PIPE OUTER DIAMETER TO PIPE OUTER DIAMETER.
 6. MINIMUM REQUIRED COVER OVER THE WATER MAIN MUST BE 48 INCHES. IF FRESH GRADE IS PROVIDED BEFORE CONSTRUCTION OF THE WATER MAIN, THE MINIMUM COVER DISTANCE SHALL BE 42 INCHES.
 7. ALL WATER MAINS, TANKS, AND FITTINGS SHALL BE DISINFECTED PER AWWA C651 PRIOR TO DISTRIBUTION OF POTABLE WATER.
 8. ALL WATER MAIN, PRESSURE TANKS, AND FITTINGS SHALL BE PRESSURE TESTING PER AWWA C600 DUCTILE IRON AND CAST IRON PRIOR TO DISTRIBUTION OF POTABLE WATER.
 9. INSTALL WATER LINES WITH CONTINUOUS POSITIVE SLOPE. ADVISE ENGINEER OF ANY LOCALIZED HIGH POINTS OR LOW POINTS.
 10. CONSTRUCT FIRE HYDRANTS ADJACENT TO THE WATER MAINS AT EVERY 1000 FT LENGTH OF PIPE PLACED PER IUCN STANDARD DETAIL W-11.
 11. INSTALL AN ISOLATION VALVE ON THE WATER MAIN AT EVERY 1000 FT LENGTH OF PIPE PLACED.
 12. WATER MAIN SHALL BE CONSTRUCTED USING CLASS 235 DR 18 PVC PIPE AND CONFORM WITH AWWA STANDARD C900.

SCALE A 1 SOUTH WATER DISTRIBUTION MAIN PLAN: STATIONS 63+50 TO 69+43.55

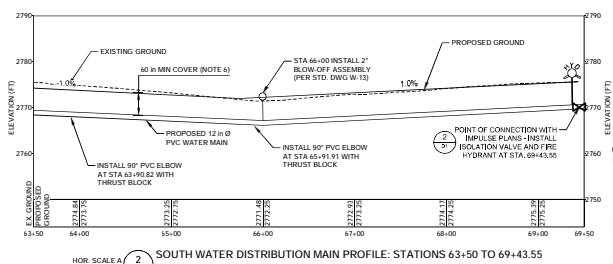

SCALE A 2 SOUTH WATER DISTRIBUTION MAIN PROFILE: STATIONS 63+50 TO 69+43.55

LINE TABLE:

LINE #	LENGTH (FT)	BEARING	START POINT (N, E)	END POINT (N, E)
L14	201.1	S3° 32' 20.2"E	(20204710.3, 1864668.4)	(20204506.2, 1864958.3)
L15	351.6	N89° 27' 39.79"E	(20204609.2, 1864668.3)	(20204512.6, 1865110.0)

CURVE TABLE:

CURVE #	RADIUS (FT)	LENGTH (FT)	START POINT (N, E)	END POINT (N, E)
C5	1000.0	63.0	(20204766.1, 1864902.4)	(20204735.2, 1864939.5)



ISSUED FOR CONSTRUCTION

<p>CLIENT DOUBLE M CONSTRUCTION C/O SPRING MOUNTAIN RACEWAY, LLC</p> <p>CONSULTANT RENO OPERATIONS 595 DOUBLE EAGLE CT, #1000 RENO, NEVADA 89521 USA 1-775-752-9604 www.gdbss.com</p>	<p>PROJECT WATER SYSTEM DESIGN SPRING MOUNTAIN MOTORSPORTS RANCH PAHRUMP, NEVADA</p> <p>TITLE SOUTH DISTRIBUTION MAIN PLAN AND PROFILE (6 OF 6)</p> <p>PROJECT No. 1520359 Rev. B 23 of 27 DRAWING P8</p>
--	---

NO.	DATE	DESCRIPTION	EMC	MSB	JC	MPB
0	2016-04-29	ISSUED FOR CONSTRUCTION				
Rev.	YYYY-MM-DD	DESCRIPTION	PREPARED	DESIGN	REVIEW	APPROVED

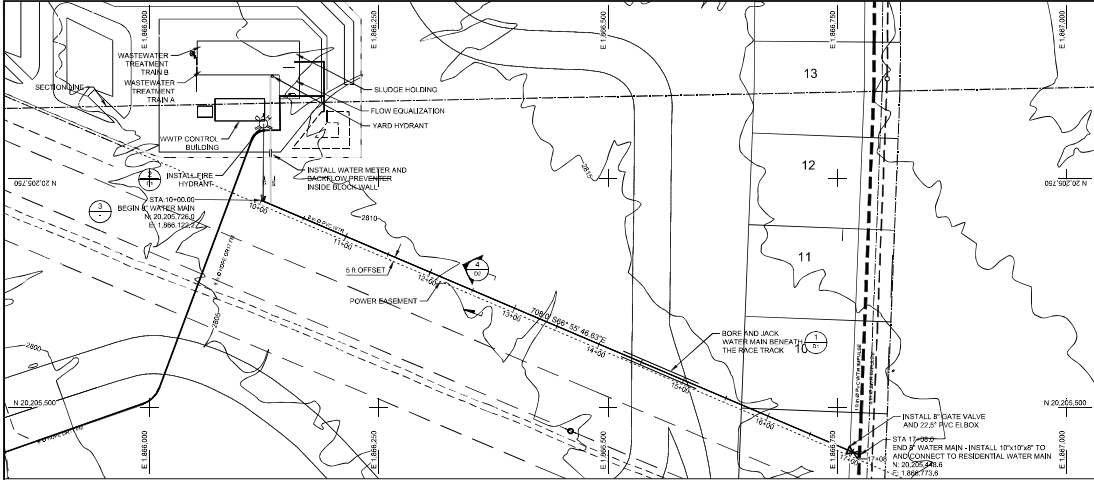

LEGEND

- EXISTING GROUND
- SECTION LINES
- EXISTING ROW
- EXISTING ROAD
- PROPOSED PAVED ROAD
- PROPOSED PIPE ACCESS ROAD
- PROPOSED WATER MAIN
- WATER SYSTEM BY IMPULSE ENGINEERING REF. RESIDENTIAL IMPROVEMENT PLANS (RAY 8, 2013)
- ISOLATION VALVE
- FIRE HYDRANT

- NOTES**
1. CONTRACTOR TO NOTIFY ALL UTILITY COMPANIES AS WELL AS THE CITY OF PAHRUMP AND IVE COUNTY'S MAINTENANCE DEPARTMENT PRIOR TO CONSTRUCTION.
 2. EXISTING UTILITIES ARE APPROXIMATE. CONTRACTOR TO POOT HOLE AND VERIFY LOCATIONS AND DEPTHS PRIOR TO CONSTRUCTION.
 3. ALL EFFORTS MUST BE MADE TO RETURN ANY DISTURBED AREAS BACK TO THEIR NATIVE CONDITION UPON THE COMPLETION OF WORK.
 4. WATER MAIN MUST BE PLACED A MINIMUM HORIZONTAL DISTANCE OF 10 FEET FROM SEWER LINES MEASURED FROM PIPE OUTER DIAMETER TO PIPE OUTER DIAMETER.
 5. WATER MAIN MUST BE PLACED A MINIMUM VERTICAL DISTANCE OF 18 INCHES FROM SEWER LINE MEASURED FROM PIPE OUTER DIAMETER TO PIPE OUTER DIAMETER.
 6. MINIMUM REQUIRED COVER OVER THE WATER MAIN MUST BE 48 INCHES IF FINISH GRADE IS PROVIDED BEFORE CONSTRUCTION OF THE WATER MAIN, THE MINIMUM COVER DISTANCE SHALL BE 42 INCHES.
 7. ALL WATER MAINS, TANKS, AND FITTINGS SHALL BE DISINFECTED PER AWWA C651 PRIOR TO DISTRIBUTION OF POTABLE WATER.
 8. ALL WATER MAIN, PRESSURE TANKS, AND FITTINGS SHALL BE PRESSURE TESTING PER AWWA C600 EXCEPT IRON AND CAST (PVC) PIPING TO DISTRIBUTION OF POTABLE WATER.
 9. INSTALL WATER LINES WITH CONTINUOUS POSITIVE SLOPE. ADVISE ENGINEER OF ANY LOCALIZED HIGH POINTS OR LOW POINTS.
 10. CONSTRUCT FIRE HYDRANTS ADJACENT TO THE WATER MAINS AT EVERY -1000 FT LENGTH OF PIPE PLACED PER IUCN STANDARD DETAIL W-11.
 11. INSTALL AN ISOLATION VALVE ON THE WATER MAIN AT EVERY -1000 FT LENGTH OF PIPE PLACED.
 12. WATER MAIN SHALL BE CONSTRUCTED USING CLASS 235 DR 18 PVC PIPE AND CONFORM WITH AWWA STANDARD C900.

SCALE A 1 WWTP WATER DISTRIBUTION LINE PLAN: STATIONS 10+00 TO 18+38.50

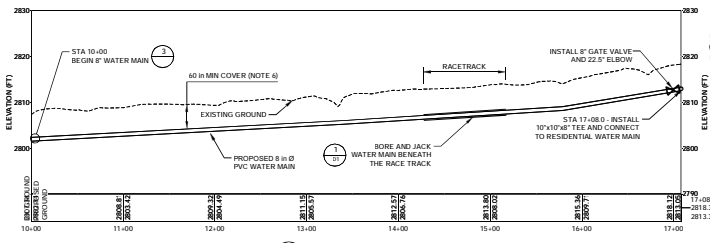

SCALE A 2 WWTP WATER DISTRIBUTION LINE PROFILE: STATIONS 10+00 TO 17+08.0

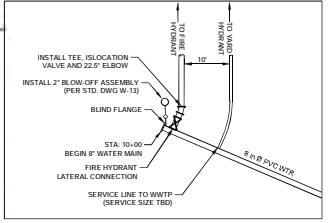

SCALE B 3 WWTP WATER DISTRIBUTION CONNECTION DETAIL

ISSUED FOR CONSTRUCTION

CLIENT DOUBLE M CONSTRUCTION C/O SPRING MOUNTAIN RACEWAY, LLC				PROJECT WATER SYSTEM DESIGN SPRING MOUNTAIN MOTORSPORTS RANCH PAHRUMP, NEVADA			
CONSULTANT 				TITLE WWTP DISTRIBUTION LINE PLAN AND PROFILE			
0 2016-04-29 ISSUED FOR CONSTRUCTION				PROJECT No. 1520359			
EMC MCB JC MFB				Rev. 24 of 27			
PREPARED DESIGN REVIEW APPROVED				DRAWING P9			

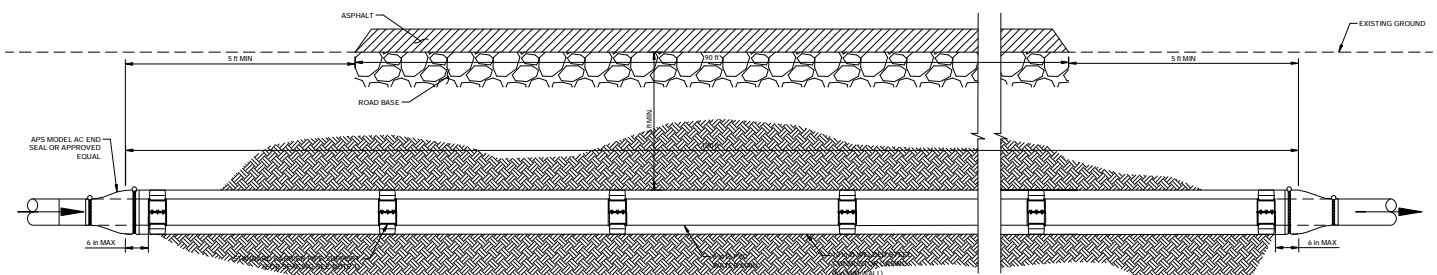

SCALE A 1 BORE AND JACK DETAIL

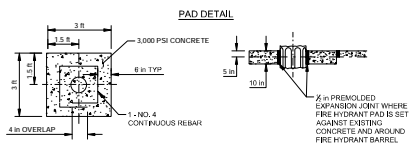

SCALE A 2 PAD DETAIL

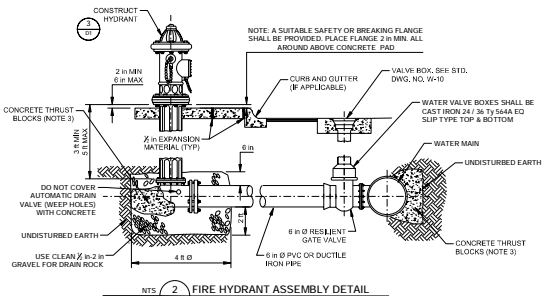

SCALE A 2 HYDRANT ASSEMBLY DETAIL

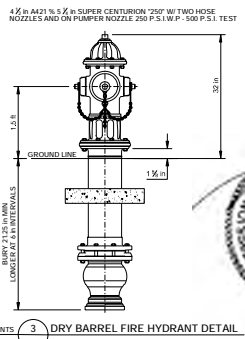

SCALE A 3 DRY BARREL FIRE HYDRANT DETAIL

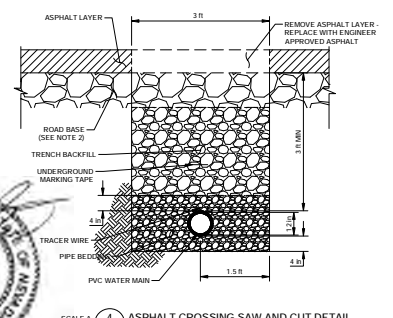

SCALE A 4 ASPHALT CROSSING SAW AND CUT DETAIL



ISSUED FOR CONSTRUCTION

- NOTES
1. SPACE CARRIER PIPE SUPPORT PER PVC MANUFACTURER'S RECOMMENDATION. SUPPORTS SHALL BE POSITIONED TO PREVENT EXCESSIVE SAG, BENDING, AND SHEAR STRESSES IN THE PIPING. APPROXIMATE SPACING FOR 8 in Ø PVC PIPE IS 6.7 ft.
 2. DETERMINE DEPTH OF ROAD BASE UPON EXCAVATION. DURING EXCAVATION STOCKPILE EXISTING ROAD SUBBASE AND REUSE DURING BACKFILLING. CARE SHALL BE TAKEN TO PREVENT CONTAMINATION WITH UNDERLYING SOILS.
 3. CONCRETE THRUST BLOCKS REQUIRED - RESTRAINED JOINTS ALLOWED ONLY WITH PRIOR AGENCY APPROVAL.

CLIENT DOUBLE M CONSTRUCTION C/O SPRING MOUNTAIN RACEWAY, LLC	PROJECT WATER SYSTEM DESIGN SPRING MOUNTAIN MOTORSPORTS RANCH PAHRUMP, NEVADA
CONSULTANT 	TITLE GENERAL DETAILS (1 OF 2)
RENO OPERATIONS 595 DOUBLE EAGLE CT. #1000 RENO, NEVADA 89521 USA 1-111-7750-628-9404 www.gulf.com	PROJECT No. 1520359
DATE 2016-04-29	REV B
DESCRIPTION ISSUED FOR CONSTRUCTION	DATE 25 of 27
DESIGNED EMC	DRAWN D1
CHECKED MDE	
IN CHARGE JC	
APPROVED MPB	

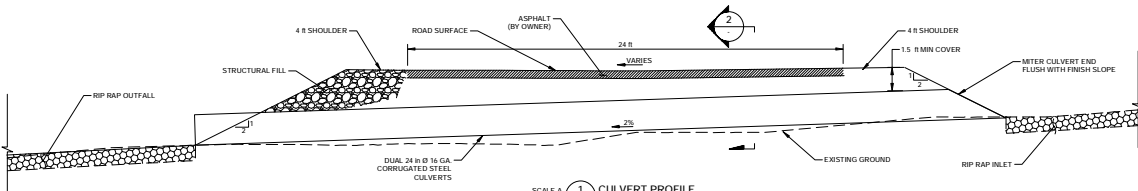

SCALE A 1 CULVERT PROFILE

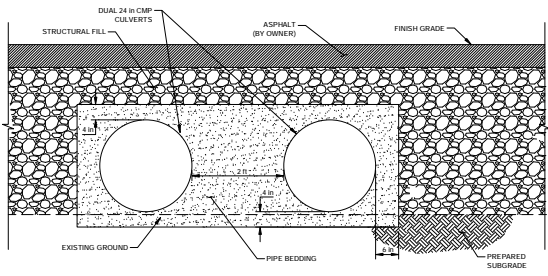

SCALE B 2 CULVERT SECTION

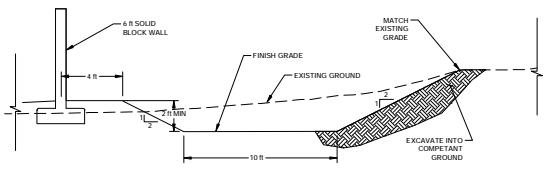

SCALE A 3 BOOSTER STATION PAD DRAINAGE CHANNEL

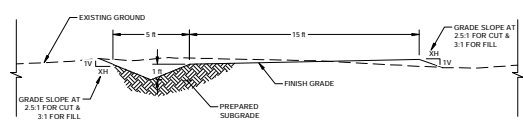

SCALE A 4 PIPE ACCESS ROAD GRADING SECTION



ISSUED FOR CONSTRUCTION

CLIENT		DOUBLE M CONSTRUCTION C/O SPRING MOUNTAIN RACEWAY, LLC				
CONSULTANT		 RENO OPERATIONS 595 DOUBLE EAGLE CT. #1000 RENO, NEVADA 89521 USA 1-11(775) 828-9404 www.geostar.com				
0	2016-04-29	ISSUED FOR CONSTRUCTION	EMC	MEB	JC	MPB
Rev.	YYYY-MM-DD	DESCRIPTION	PREPARED	DESIGN	REVIEW	APPROVED

PROJECT		WATER SYSTEM DESIGN SPRING MOUNTAIN MOTORSPORTS RANCH PAHRUMP, NEVADA	
TITLE		GENERAL DETAILS (1 OF 2)	
PROJECT No.	1520359	Rev.	B
		26 of 27	DRAWING D2

**APPENDIX B
TECHNICAL SPECIFICATIONS**

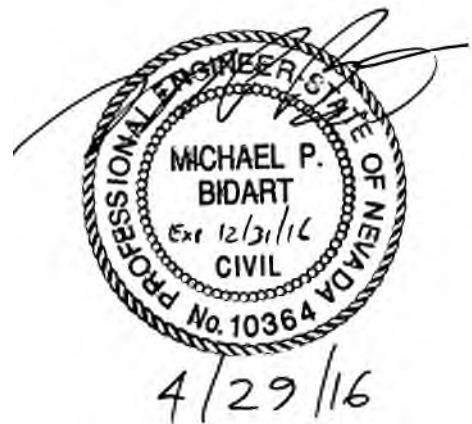

Table of Contents

Specification Number	Specification Title	Revision	DATE
01010	Summary of Work	0	April 2016
01025	Measurement and Payment	0	April 2016
01035	Modifications Procedure	0	April 2016
01041	Project Coordination	0	April 2016
01050	Field Engineering	0	April 2016
01091	Reference Standards	0	April 2016
01092	Abbreviations	0	April 2016
01200	Project Meetings	0	April 2016
01300	Contractor Submittals	0	April 2016
01400	Quality Control	0	April 2016
01505	Mobilization	0	April 2016
01515	Temporary Utilities	0	April 2016
01530	Protection of Utilities	0	April 2016
01535	Safety	0	April 2016
01550	Access Roads and Parking	0	April 2016
01560	Temporary Environmental Controls	0	April 2016
01600	Materials and Equipment	0	April 2016
01630	Options and Substitutions	0	April 2016
01710	Cleaning	0	April 2016
01730	Operation and Maintenance Data	0	April 2016
01740	Warranties	0	April 2016
02200	Earthworks	0	April 2016
02225	Trench Excavation and Backfill	0	April 2016
02340	Boring and Jacking	0	April 2016
02610	Aggregate Base Course	0	April 2016
02621	General Piping System and Appurtenances	0	April 2016
02625	Pressure Pipe – Valves and Fittings	0	April 2016
02675	Pressure and Leakage Testing	0	April 2016
02680	Water Main Disinfection	0	April 2016
03150	Formwork for Cast-in-Place Concrete	0	April 2016
03200	Reinforcing Steel	0	April 2016
03300	Cast-in-Place Concrete	0	April 2016
03470	Precast Vaults	0	April 2016
11205	Flow Meters and Gauges	0	April 2016
11211	Pre-Engineered Booster Pump Station	0	April 2016
11261	Chlorination Equipment	0	April 2016
15200	Welded Steel Water Storage Tank	0	April 2016
15210	Steel Tank Interior and Exterior Coating	0	April 2016



SECTION 01010

SUMMARY OF WORK

PART 1 GENERAL

1.01 SUMMARY

- A. Construction of a water system for a new development, and ancillary work and appurtenances required for complete installation. The project will consist of two groundwater wells, storage tanks, booster pump station, and distribution mains.
 - 1. The wells sites work includes all construction and materials required to complete the well site system including, but not limited to, well buildings, site grading, concrete work, fencing, pump-to-waste sump, plumbing, piping, chlorination system, site electrical, controls, and heating and ventilation.
 - 2. The storage tanks work includes all construction and materials required to complete the 550,000 gallon storage tanks including, but not limited to, site grading, steel tank structure, retaining ring, mushroom vent, bearing plate, silt stops, overflow weir box, outward shell manways, interior and exterior ladders, roof entry hatch, j-vents, level indicator, outfall structure and all plumbing and piping required to connect to the upstream wells and downstream booster pump station.
 - 3. The booster pump station work includes all construction and materials required to complete the booster pump station including, but not limited to, the building, site grading, concrete work, plumbing, piping, chlorination system, site electrical including the generator, controls, and heating and ventilation.
 - 4. The transmission mains work includes all construction and materials required to complete the pipeline distribution system including, but not limited to, connection to the booster station piping, grading, excavation, piping, hydrants, isolation valves, jack and boring, and connections to the residential water mains and the wastewater treatment plant.
- B. Furnish tools, equipment, materials, supplies, and manufactured articles; furnish transportation and services including fuel, power, water, and essential communications; and perform labor, work or other operations required in accordance with the Construction Documents.
- C. The Work shall be complete, and all work, materials, and services not expressly shown or called for in the Construction Documents which may be necessary for the complete and proper construction of the Work in good faith shall be performed, furnished, and installed by Contractor as though originally so specified or shown, at no increase in cost to Owner.

1.02 STREAMLINED SPECIFICATIONS

- A. These specifications are written in the streamlined or declarative style utilizing incomplete sentences.

- B. Omissions of such words and phrases as "The Contractor shall." "in conformity therewith," "shall be," "as shown on the Drawings," "a", "an," "the," and "all" are intentional in streamlined sections.
 - 1. Omitted words shall be supplied by inference in the same manner as when a note appears on the drawings.
 - 2. The omission of such words shall not relieve the Contractor from providing all items and work described herein or indicated on the drawings.

1.03 CONTRACT METHOD

- A. The work hereunder will be constructed under a single Lump Sum Contract.

1.04 WORK BY OTHERS

- A. Work may be conducted at or near the site by other contractors during the performance of the Work under this Contract.
- B. Conduct operations to cause a minimum of interference with work of other contractors and cooperate fully with other contractors.
- C. Interference with Work on Utilities:
 - 1. Cooperate fully with utility forces of Owner or forces of public or private agencies engaged in relocating, altering, or otherwise rearranging of facilities which interfere with the progress of the Work.
 - 2. Schedule the Work to minimize interference with relocating, altering, or other rearranging of facilities.

1.05 CONTRACTOR'S USE OF PROJECT SITE

- A. Contractor's use of project site shall be limited to construction operations, including onsite storage of materials, onsite fabrication facilities, and field offices.
- B. Limit use of site to areas defined by Owner and/or construction limits.
 - 1. Limit use of premises for work and storage to allow for work of other contractors and subcontractors.
 - 2. Notify Owner of any work necessary to complete the Work is outside the construction limits shown.
- C. Owner will have complete control over the use of the site by Contractor. Discuss intended use of site with Owner before starting work.
- D. Assume full responsibility for the protection and safe keeping of products stored on the site.

E. Move stored products as directed by the Engineer which interfere with operations of Owner or separate contractors.

F. Obtain and pay for the use of additional storage and work areas needed for operations.

1.06 PERMITS

A. Obtain all permits required for construction, not already obtained by the Owner.

B. Pay the required fees and acquire all permits required for the construction of the project.

1.07 WORK SEQUENCE

A. Schedule activities to accommodate the overall construction schedule of Owner and coordinate the detailed schedule with Owner.

B. Perform work in an expeditious manner to ensure completion at the earliest possible date, but in no case later than the completion dates to be made available to Contractor by Owner.

C. A construction schedule will be developed by the contractor and will be submitted for review to the owner.

1.08 COMPLETION OF THE WORK

A. For Contract purposes, the completion date of the Contract will be deemed to be the date of final completion of the project, including specially scheduled items.

PART 2 PRODUCTS

Not used.

PART 3 EXECUTION

Not used.

END OF SECTION

SECTION 01025

MEASUREMENT AND PAYMENT

PART 1 GENERAL

1.01 SECTION INCLUDES

- A. Lump sum base bid description for Contract.
- B. Measurement criteria applicable to the price schedule.
- C. Defect assessment and non-payment for rejected work

1.02 AUTHORITY

- A. Take all measurements and compute quantities. Owner will verify measurement and quantities.
- B. Assist by providing necessary equipment, workers, and survey personnel as required.

1.03 UNIT QUANTITIES SPECIFIED

- A. Quantities indicated on the Plans are for bidding and contract purposes only. Quantities and measurements supplied or placed in the Work and verified by the Owner determine basis for estimated monthly pay requests only and are not the basis for changes to the total lump sum price.
- B. If the actual Work requires more or fewer quantities than those quantities indicated on the Plans, provide the required quantities with no change in the lump sum price, unless those quantities change as a result of a change in the scope of work after award of the Contract.
- C. If the actual Work requires a 25 percent or greater change in quantity less than or more than any quantity indicated, Owner or Contractor may claim for a Contract Price adjustment.

1.04 MEASUREMENT OF QUANTITIES

- A. Measurement Devices:
 - 1. Weight Scales: Inspected, tested, and certified by the applicable agency Weights and Measures department within the past year.
 - 2. Platform Scales: Of sufficient size and capacity to accommodate the conveying vehicle.
 - 3. Metering Devices: Inspected tested and certified by the applicable agency department within the past year.
- B. Measurement by Volume: Measured by cubic dimension using mean length. Width, and height or thickness.

- C. Measurement by Area: Measured by square dimension using mean length and width or radius.
- D. Linear Measurement: Measured by linear dimension, at the item centerline or mean chord.
- E. Stipulated Price Measurement: Items measured by weight, volume, area, or linear means or combination, as appropriate, as a completed item or unit of the Work.

1.05 PROGRESS PAYMENTS

- A. Payments for materials, machinery or equipment not incorporated into the Work, but delivered and suitably stored at the site, shall only be made where permitted by, and in accordance with, the terms and conditions of the Contract Documents.
 - 1. Title to materials, machinery, and equipment delivered and suitably stored at the site shall immediately vest in and become the sole property of the Owner upon delivery to the site.
 - 2. Notwithstanding such transfer of title, the Contractor shall have the full continuing responsibility to install, protect, and maintain the products in proper condition and promptly repair, replace and make good damage thereto without cost to the Owner until the Work is fully accepted by the Owner.
 - 3. Transfer of title shall in no way affect Contractor's obligations under the Contract.
- B. Where the Contract Documents permit payment for materials stored off the jobsite. Owner shall have discretion either to approve or disapprove payments for such materials, and Contractor shall, in addition to the other requisites of the Contract Documents, make any provisions necessary, including insurance covering loss or damage to the material, to insure and protect Owner's title and right of possession and access to any such materials for which payment is approved by Owner.
- C. Payments otherwise due, may be withheld by Owner because of defective work not remedied, claims filed, reasonable evidence indicating probability of filing of claims, failure of Contractor to make payments properly to its subcontractors or for materials, machinery, fuel or labor, or applicable taxes, fees and fringe benefits or reasonable doubt that the Contract can be completed for the balance then unpaid, or for any other breach of this Contract or for any other causes specified in the Contract Documents.
 - 1. If the causes are not removed, on written notice, Owner may rectify the same at Contractor's expense.
 - 2. Owner may offset against any sums due Contractor, the amount of any liquidated or unliquidated obligations of Contractor to Owner, whether or not arising out of this Contract.
- D. No payment to Contractor shall operate as an approval of Contractor's work or material, or any part thereof, or to release Contractor from obligations under this Contract.
- E. Format of Payment Applications:

1. Contractor's electronic media driven form including continuation sheets when required.
2. For each item, provide a column for listing each of the following:
 - a. Item Number.
 - b. Description of Work
 - c. Scheduled Values.
 - d. Previous Applications.
 - e. Work in Place and Stored Materials under this Application.
 - f. Authorized Change Orders.
 - g. Total Completed and Stored to Date of Application.
 - h. Percentage of Completion.
 - i. Balance to Finish.
 - j. Retainage.

F. Preparation of Applications:

1. Present required information on electronic media printout.
2. Execute certification by signature of authorized officer.
3. Use data from approved Schedule of Values. Provide dollar value in each column for each line item for portion of work performed and for stored Products.
4. List each authorized Change Order, including number and dollar amount as for an original item of work.
5. Prepare Application for Final Payment.

G. Submittal Procedures:

1. Submit three copies of each Application for Payment.
2. Submit an updated Construction schedule with each Application for Payment.
3. Payment Period: Submit at intervals stipulated in the Agreement.
4. Submit with transmittal letter as specified for Submittals in Section 01300.
5. Submit Owner required waivers.

H. Substantiating Data:

1. When Engineer requires substantiating information, submit data justifying dollar amounts in question.
2. Provide one copy of data with cover letter for each copy of submittal. Show application number and date, and line item by number and description.

1.06 PAYMENT

- A. Payment includes: Full compensation for all required labor, materials, tools, equipment, plant, transportation, services, and incidentals; excavation, removal, erection, application, or installation of an item of Work; overhead and profits.
- B. Final payment for Work governed by unit prices will be made on the basis of the actual measurements and quantities accepted by the Owner multiplied by the unit price for Work which is incorporated in or made necessary by the Work.

1.07 DEFECT ASSESSMENT

- A. Replace the Work, or portions of the Work, not conforming to specified requirements.
- B. If, in the opinion of Owner's Representative, it is not practical to remove and replace the Work, Owner will direct one of the following remedies:
 - 1. The defective Work may remain, but the unit price will be adjusted to a new price at the discretion of the Owner.
 - 2. The defective Work will be partially repaired to the instructions of the Owner's Representative and Owner, and the unit price will be adjusted to a new price at the discretion of the Owner.
- C. The authority of Owner to assess the defect and identify payment adjustment is final.

1.08 LUMP SUM BASE BID

- A. The Lump Sum Base Bid is the total lump sum cost for the base bid items, including all labor, materials, and equipment for the scope of work described in Section 01010, Summary of Work.
- B. Lump sum price also includes all bonds, insurance, and surety.
- C. Contractor agrees to meet all schedules set forth for in this project.

PART 2 PRODUCTS

Not used.

PART 3 EXECUTION

Not used.

END OF SECTION

SECTION 01035

MODIFICATIONS PROCEDURE

PART 1 GENERAL

1.01 SUMMARY

- A. The Work to be performed may be modified by changes required by Owner and the Contract Amount and/or the Contract Time set forth in the Agreement will be adjusted by written Change Order in accordance with this section.
- B. No alterations, increases or decreases shall be made in the Work as shown and specified except on the written order of Owner, and when so made, the value of the Work or materials added or omitted shall be computed and determined by Contractor, subject to the written approval and acceptance by Owner, and the Amount so determined shall be added to or deducted from the Contract Amount.
 - 1. Contractor shall have no claim for additional Work or changed work unless such Work has been done in pursuance of a written order from Owner.
 - 2. Extra Work performed without written order will be at Contractor's expense.

1.02 FIELD ORDERS

- A. Owner and Owner's Representative will have authority to order minor changes in the Work not involving an adjustment in the Contract Amount or Time and not inconsistent with the intent of the Construction Documents.
 - 1. Changes shall be effected by written order and shall be binding on Contractor.
 - 2. Contractor shall carry out written order promptly.

1.03 CHANGE ORDER PROCEDURES

- A. If a change in the Work is desired, Owner will notify Contractor and provide a written description, in the form of drawings or otherwise, of the desired change.
- B. Contractor shall submit to Owner, a firm proposal for any changes in the Contract Amount and/or Time resulting from the proposed change within five days after receipt of the proposed change and shall submit the actual Change Order Request within ten days.
- C. Owner shall have thirty days, or such other time as may be agreed upon, in which to accept or reject Contractor's proposal after its submission, and Contractor shall not modify or withdraw the proposal during this period.
- D. The cost or credit to Owner resulting from a change in Contractor's work shall be determined in one of the following ways:

1. By mutually agreed lump sum properly itemized and supported by sufficient substantiating data to permit evaluation in accordance with the Construction Documents (which may be evidenced by Owner's issuance to Contractor of a Change Order for Contractor's firm proposal as described above);
 2. By unit prices stated in the Construction Documents or subsequently agreed upon; or
 3. On the basis of reasonable costs and savings of those performing the Work attributable to the change; provided, however, that in no case shall contractor's firm proposal described above nor any other method for determining the amount of the change include any cost for:
 - a. Materials, labor, machinery, fuel or other expenses not specifically reimbursable as identified in the article, Cost Limitations, below, or
 - b. Allowance for overhead and profit in excess of ten percent.
- E. Contractor shall, provided a written order signed by Owner is received, promptly proceed with the Work involved.
- F. In the event Owner directs Contractor to perform change in the Work by a written order other than a signed Change Order and without agreeing to the Contractor's firm proposal, then Contractor shall proceed to perform the change and the amount of the change shall be determined either under D,2 above (to the extent unit prices may be applied to the Work involved) or under D,3 above, as Owner may elect in its sole discretion, unless a mutually acceptable lump Sum price is subsequently agreed upon.
1. To the extent Owner elects D,2, the unit price shall be as described in the Contract Documents.
 2. To the extent that D,1 or D,3 is elected, the cost of the Work and any savings shall be determined in accordance with Cost Limitations article, below.
- G. In the event of additional Work ordered by Owner, Contractor shall submit labor and time card sheets, with description of the Work and materials supplied, to the Owner's Representative daily. This document shall govern in determining the workers' time and equipment usage involved in time-and-material-based charges, unless later found to be incorrect.
- H. If Owner or Engineers disputes the validity or amount of a Change Order Request submitted by Contractor but Owner nevertheless directs Contractor to proceed, Contractor shall promptly proceed with the Work under the Change Order pending resolution of the dispute and expeditiously complete such work.
- I. If Contractor wishes to make any other claim for an increase in the Contract Amount, Contractor shall give Owner written notice thereof within twenty days after the occurrence of the event giving rise to such claim, but nothing contained herein shall be deemed to permit Contractor to claim damages on account of delays in Contractor's performance of the Work or interference therewith, it being agreed that Contractor's sole remedy shall be to obtain an extension of time as provided in the Construction Documents.

1.04 COST LIMITATIONS

A. Cost shall be limited to the following:

1. Cost of materials, including sales tax and cost of delivery;
2. Cost of labor, including social security, old age and unemployment insurance, and fringe benefits required by agreement or custom;
3. Workers' compensation insurance;
4. Bond premiums;
5. Rental value of equipment and machinery;
6. Additional costs of supervision and field office personnel directly attributable to the change.

B. When both additions and credits covering related Work or substitutions are involved in a change, the allowance for overhead and profit shall be figured on the basis of the net increase, if any, with respect to such change.

1.05 CHANGE ORDER REQUEST

A. Change Order Request shall consist of the detailed cost estimate outlining the changes in the Work and detailed documentation justifying proposed changes in time.

1. Compute estimate in accordance with accepted estimating procedures and in accordance with the terms of the Construction Documents.
 - a. Costs for labor, machinery, fuel and materials shall be at prevailing rates or wage scales pertinent to the project.
2. Unless otherwise provided in the Construction Documents, labor costs shall mean wages paid for labor under prevailing wage rates, or under a salary and wage scale agreed upon by Owner and Contractor, and shall include welfare and other benefits, if any, as may be payable with respect thereto in accordance with any applicable salary and wage scale.

PART 2 PART 2 - PRODUCTS

Not used.

PART 3 PART 3 – EXECUTION

Not used.

END OF SECTION

SECTION 01041

PROJECT COORDINATION

PART 1 GENERAL

1.01 SECTION INCLUDES

- A. Coordination.
- B. Examination.
- C. Preparation.

1.02 COORDINATION

- A. Coordinate scheduling submittals, and Work of the various sections of the construction specifications to assure efficient and orderly sequence of interdependent construction elements.
- B. Coordinate space requirements and installations. Utilize spaces efficiently to maximize accessibility.
- C. Coordinate completion and clean up of Work of separate sections in preparation for Substantial Completion.
- D. After Owner occupancy of premises, coordinate access to site for correction of defective Work and Work not in accordance with Construction Documents, to minimize disruption of Owner's activities.

PART 2 PRODUCTS

Not used.

PART 3 EXECUTION

3.01 EXAMINATION

- A. Verify that existing site conditions are acceptable for subsequent Work. Beginning Work means acceptance of existing conditions.
- B. Examine and verify specific conditions described in individual specification sections.
- C. Verify that utility services are correctly located.

END OF SECTION

SECTION 01050

FIELD ENGINEERING

PART 1 GENERAL

1.01 WORK INCLUDED

- A. This Section specifies the layout and establishment of field boundaries and grades, lines, and elevations for the Work.

1.02 OWNER FURNISHED STAKES

- A. Owner will provide construction stakes establishing lines and grades for the Work, as follows:
 - 1. One permanent benchmark in the vicinity of the Project site.
 - 2. Stakes at 50 foot intervals for piping, and at structures; stakes placed along offset lines chosen by Contractor.
 - 3. Two stakes, containing horizontal and vertical control, at each structure location.
 - 4. Stakes not delineated above which Engineer may determine are necessary to complete the Work
- B. The above construction stakes shall constitute the field control by and in accordance with which Contractor shall execute the Work, and will be furnished at no expense to Contractor.

1.03 CONTRACTOR FURNISHED STAKES

- A. Engineer will set stakes in addition to those delineated above, if required and requested by Contractor; however, costs for setting additional stakes shall be paid for by Contractor, or will be deducted from any amounts due or to become due to Contractor.
- B. After stakes and marks have been set, it shall be responsibility of Contractor to protect the stakes.
- C. Should any of the stakes be disturbed by Contractor's operations, the costs for replacing the stakes and marks shall be paid for by Contractor, or will be deducted from amounts to become due Contractor.

PART 2 PRODUCTS

Not used.

PART 3 EXECUTION

3.01 EXAMINATION

- A. Verify locations of survey control points prior to starting work.
- B. Promptly notify Engineer of any discrepancies discovered.

END OF SECTION

SECTION 01091

REFERENCE STANDARDS

PART 1 GENERAL

1.01 TITLES OF SECTIONS

- A. Captions accompanying specification sections are for convenience or reference only and do not form a part of the Construction Documents.

1.02 APPLICABLE PUBLICATIONS

- A. When references are made to published specifications, codes, standards, or other requirements, and no date is specified only the latest specifications standards, or requirements of the respective issuing agencies, which have been published as of the date that the Work is advertised for bids, shall apply; except to the extent that standards or requirements may be in conflict with applicable laws, ordinances, or governing codes.
- B. No requirements specified or shown on Drawings shall be waived because of any provision of, or omission from, standards or requirements.

1.03 SPECIALISTS ASSIGNMENTS

- A. Specification text may require (or imply) that specific work be assigned to specialists or expert entities who must be engaged to perform that work
- B. Such assignments are special requirements over which Contractor has no choice or option.
- C. These requirements shall not be interpreted so as to conflict with enforcement of building codes and similar regulations governing the Work nor to interfere with local union jurisdiction settlements and similar conventions.
- D. Such assignments are intended to establish which party or entity involved in specific unit of work is recognized as "expert" for the indicated construction processes or operations
- E. Final responsibility for fulfillment of Contract requirements remains with Contractor.

1.04 REFERENCE SPECIFICATIONS, CODES, AND STANDARDS

- A. Work specified shall conform to or exceed requirements of applicable codes and applicable requirements of documents listed below to the extent that the provisions of such documents are not in conflict with requirements of these Specifications or applicable codes.
- B. "Building Code" or "UBC" shall mean the Uniform Building Code of the International Conference of Building Officials (ICBO). The latest edition of the code as approved and used by the local agency as of the date of award, as adopted by the agency having jurisdiction, shall apply to the Work herein, including all addenda, modifications, amendments, or other lawful changes thereto.

- C. In case of conflict between codes, reference standards, Drawings and other Construction Documents, the most stringent requirements shall govern.
 - 1. Bring conflicts to the attention of Owner for clarification and directions prior to ordering or providing materials or labor.
 - 2. Bid the most stringent requirements.
- D. Applicable Standard Specifications:
 - 1. Construct the Work in accordance with requirements of the Construction Documents and the referenced portions of those referenced codes, standards, and specifications listed.
 - 2. Wherever references to "Standard Specifications" are made, the contractual, measurement, and payment provisions therein shall not apply.
- E. "Standard Specifications" shall mean the most recent edition of the "Standard Specifications for Public Works Construction", Nye County, Nevada, (Orange Book), including all current supplements, addenda, and revisions thereto.
- F. "Standard Drawings" shall mean the most recent edition of the "Standard Details for Public Works Construction, Nye County, Nevada, including all current supplements, addenda, and revisions thereto.
- G. "OHSAs Regulations for Construction" shall mean Title 29, Part 1926, Construction Safety and Health Regulations, Code of Federal Regulations (OSHA), including changes and amendments thereto.
- H. "OHSAs Standards" shall mean Title 29, Part 1910, Occupational Safety and Health Standards, Code of Federal Regulations (OSHA), including changes and amendments thereto.

PART 2 PRODUCTS

Not used.

PART 3 EXECUTION

Not used.

END OF SECTION

SECTION 01092

ABBREVIATIONS

PART 1 GENERAL

1.01 SUMMARY

- A. References made to standards, specifications, or other published data of various national, regional, or local organizations, may refer to such organizations by their acronym or abbreviation only.
- B. The following acronyms or abbreviations may appear in these Construction Documents and shall have the meanings indicated.

1.02 ABBREVIATIONS AND ACRONYMS

AAMA	Architectural Aluminum Manufacturer's Association
AASHTO	American Association of the State Highway and Transportation Officials
ACI	American Concrete Institute
AGA	American Gas Association
AGMA	American Gear Manufacturer's Association
AI	The Asphalt Institute
AIA	American Institute of Architects
AISC	American Institute of Steel Construction
AISI	American Iron and Steel Institute
AITC	American Institute of Timber Construction
ANSI	American National Standards Institute, Inc.
APA	American Plywood Association
API	American Petroleum Institute
AEWA	American Public Works Association
ASCE	American Society of Civil Engineers
ASME	American Society of Mechanical Engineers
ASQC	American Society of Quality Control
ASSE	American Society of Sanitary Engineers
ASTM	American Society of Testing and Materials
AWPA	American Wood Preservers Association
APWI	American Wood Preservers Institute
AWS	American Welding Society
AWWA	American Water Works Association
BBC	Basic Building Code, Building Officials and Code Administrators International
CBM	Certified Ballast Manufacturers
CEMA	Conveyors Equipment Manufacturer's Association
CGA	Compressed Gas Association
CLFMI	Chain Link Fence Manufacturer's Institute
CMA	Concrete Masonry Association
CRSI	Concrete Reinforcing Steel Institute
ELA	Electronic Industries Association
ETL	Electrical Test Laboratories
ICBO	International Conference of Building Officials

IEEE	Institute of Electrical and Electronics Engineers
IES	Illuminating Engineering Society
IME	Institute of Makers of Explosives
IP	Institute of Petroleum (London)
IPCEA	Insulated Power Cable Engineers Association
ISA	Instrument Society of America
IOS	International Organization for Standardization
ITE	Institute of Traffic Engineers
MBMA	Metal Building Manufacturer's Association
MPTA	Mechanical Power Transmission Association
NAAM	National Association of Architectural Metal Manufacturer's
NACE	National Association of Corrosion Engineers
NBS	National Bureau of Standards
NEC	National Electrical Code
NEMA	National Electrical Manufacturers's Association
NFPA	National Fire Protection Association
NFPA	National Forest Products Association
NGU	National Lubricating Grease Institute
NWMA	National Woodwork Manufacturer's Association
OSHA	Occupational Safety and Health Administration
PCA	Portland Cement Association
RWMA	Resistance Welder Manufacturer's Association
SAMA	Scientific Apparatus Makers Association
SMA	Screen Manufacturer's Association
SPR	Simplified Practice Recommendation
SSPC	Steel Structures Painting Council
SSPWC	Standard Specifications for Public Works Construction
UBC	Uniform Building Code
UL	Underwriters Laboratories, Inc.
UICN	Utilities Inc. of Central Nevada
WCLIB	West Coast Lumber Inspection Bureau
WCRSI	Western Concrete Reinforcing Steel Institute
WRI	Wire Reinforcement Institute, Inc.

PART 2 PRODUCTS

Not used.

PART 3 EXECUTION

Not used.

END OF SECTION

SECTION 01200

PROJECT MEETINGS

PART 1 GENERAL

1.01 PRECONSTRUCTION CONFERENCE

- A. Prior to commencement of Work at site, a preconstruction conference will be held at a mutually agreed time and place. The conference shall be attended by:
1. Contractor and its superintendent.
 2. Principal subcontractors.
 3. Engineer.
 4. Representatives of owner.
 5. Governmental representatives as appropriate.
 6. Others as requested by Contractor, Owner, or Engineer.
- B. Unless previously submitted to Owner, bring to the conference a tentative schedule for each of the following:
1. Progress.
 2. Procurement
 3. Values for progress payment purposes.
 4. Shop Drawings and other submittals.
- C. The purpose of the conference is to designate responsible personnel and establish a working relationship. Matters requiring coordination will be discussed and procedures for handling such matters will be established. The agenda will include:
1. Contractor's tentative schedules.
 2. Transmittal, review and distribution of Contractor's submittals.
 3. Processing applications for payment.
 4. Maintaining record documents.
 5. Critical work sequencing.
 6. Field decisions and Change Orders.

7. Use of premises, office and storage areas, security, housekeeping, and Owner's needs.
 8. Major equipment deliveries and priorities.
 9. Contractor's assignments for safety and first aid.
- D. Engineer will preside at the pre construction conference and will arrange for keeping the minutes and distributing the minutes to all persons in attendance.

1.02 PROGRESS MEETINGS

- A. Schedule and administer regular onsite progress meetings at least weekly and at other times as required by Owner or as required by progress of the Work.
- B. Make arrangements for meetings, prepare agenda with copies for participants who preside at meetings.
- C. Contractor and all subcontractors active on the site shall be represented at each meeting. Contractor may request attendance by representatives of suppliers, manufacturers and other subcontractors as appropriate to agenda topics for each meeting.
- D. Owner's Representative will preside at the meetings, record minutes and distribute copies to participants and those affected by decisions made.
- E. Agenda
 1. Review minutes of previous meetings.
 2. Review of Work in progress.
 3. Field observations, problems, and decisions.
 4. Identification of problems which impede planned progress.
 5. Review of submittals schedule and status of submittals.
 6. Maintenance of progress schedule.
 7. Corrective measures to regain projected schedules.
 8. Planned progress during succeeding work period.
 9. Coordination of projected progress.
 10. Maintenance of quality and work standards.
 11. Other business relating to Work.

PART 2 PRODUCTS

Not used.

PART 3 EXECUTION

Not used.

END OF SECTION

SECTION 01300

CONTRACTOR SUBMITTALS

PART 1 GENERAL

1.01 SECTION INCLUDES

- A. Submittal procedures.
- B. Construction progress schedule.
- C. Schedule of Values.
- D. Shop Drawings.
- E. Inspection Certificates.
- F. Spare Parts.
- G. Mix Designs.
- H. Omissions or Errors in Submitted Data.

1.02 SUBMITTAL PROCEDURES

- A. Accompany submittals by transmittal using format bound with Construction Documents or substitute form approved by Engineer. Submittals not accompanied by a form, or where all applicable items on form are not completed, will be returned for resubmittal.
 - 1. Use separate transmittal form for each specific item or class of material or equipment for which a submittal is required.
 - 2. Transmittal of shop drawings for various items using a single transmittal form will be permitted only when the items taken together constitute a manufacturer's "package" or are so functionally related that expedience indicates review of the group or package as a whole.
- B. Sequentially number the transmittal form. Revise submittals with original number and a sequential alphabetic section number, as appropriate.
- C. Identify Project, Contractor, subcontractor or supplier; pertinent drawing and detail number, and specification section number, as appropriate.
- D. Apply Contractor's stamp, signed or initialed certifying that review, verification of Products required field dimensions, adjacent construction Work, and coordination of information is in accordance with requirements of Construction Documents.
- E. Schedule submittals to expedite the Project, and deliver to engineer. Coordinate submission of related items.

- F. For each submittal for review, allow 2 to 4 days excluding delivery time to and from Contractor.
- G. Identify variations from Construction Documents and Product or system limitations which may be detrimental to successful performance of the completed Work.
- H. Provide space for Contractor and Engineer review stamps.
- I. Revise and resubmit, identify all changes made since previous submission.
- J. Distribute copies of reviewed submittals as appropriate. Instruct parties to promptly report any inability to comply with provisions.
- K. Submittals not requested will not be recognized or processed.

1.03 CONSTRUCTION SCHEDULE

- A. Prepare and submit to Owner for approval, a Project Construction Schedule showing proposed sequence to carry out Work within the Contract Time and showing beginning times and completion times for major items of work
- B. Project Construction Schedule:
 - 1. In the form of a time-scaled item-numbered network diagram.
 - 2. Supplement diagram by activity listing used in its preparation and outline, in sufficient detail:
 - a. Proposed operations.
 - b. Interrelationships of the various operations.
 - c. Order of performance so that progress of Work can be evaluated accurately at any time during performance of the Contract.
- C. Conform Project Construction Schedule to the following requirements:
 - 1. Time of Completion: Adhere to time specified unless an earlier (advanced) time of completion is requested or agreed to by Owner.
 - 2. Construction Schedule Submittal: Within ten working days after receiving notice of award, furnish to Owner a schedule showing general plan for orderly completion of Work, details of planned mobilization of plant and equipment, sequence of early operations and procurement of materials and equipment.
 - 3. Accepted Construction Schedule: Within five working days after receiving notice of acceptance of schedule furnish to Owner one reproducible and three prints of approved schedule.

4. Contractor's Responsibility: Failure of Construction Schedule to include any element of Work, or any inaccuracy in the Construction Schedule will not relieve Contractor from responsibility for accomplishing Work in accordance with the Contract.
5. Float (Slack) Time:
 - a. Amount of time between earliest start date and latest start date or between earliest finish date and latest finish date of activities of Construction Schedule.
 - b. No time extensions or delay costs will be allowed for delays on paths of activities containing float time, providing such delay does not exceed the float time, per the latest updated version of the accepted Construction Schedule.

D. Format of Construction Schedule:

1. Time-scale arrow diagram of the Critical Path Method (CPM) type, or a time-scale precedence diagram. Include in Schedule of Values, itemized descriptions, quantities, and values of work included in each activity in the Construction Schedule.
2. Construction Schedule shall provide the following:
 - a. Time-scaled cost loaded CPM diagram precedence (activity on node) of activities, coordinated with Owner.
 - b. Activity Durations:
 - 1) Total of actual days required to perform that activity including consideration of weather impact on completion of that activity.
 - 2) No duration longer than 14 days, with exception of procurement activities, unless otherwise acceptable to Owner.
 - c. Sufficient detail to show plan for completion of Work for each stage within time specified.
 - d. Milestone activities showing point of completion for each stage of Work.
 - e. Dependencies (or relationships) and logic between activities.
 - f. Information for material or equipment to be provided as follows:
 - 1) Material or equipment description.
 - 2) Duration in days required for preparation and review of Submittals.
 - 3) Duration in days required for fabrication and delivery
 - 4) Restraints (ties) to activities which will be constrained by delivery date of materials or equipment item.

- 5) Scheduled delivery dates.
 - g. Total contract value to be earned from performing each activity shall be the total of labor, material and equipment, including overhead and profit. Any material value assigned shall be actual invoice value of material, without markup. Sum of the value of items in Construction Schedule and Schedule of Values shall equal total contract value.
 - h. Assign a responsibility code/organization code for each activity, as approved by Owner.
 - i. Assign at least seven days for development of punch list(s), completion of punch list items, and final cleanup.
- E. Acceptance of Construction Schedule will not relieve Contractor of responsibility for accomplishing Work in accordance with the Contract
- F. Monthly Updates: Submit an up-to-date Status Report each month to include:
- 1. Estimated physical percentage complete for each activity in progress.
 - 2. Actual start/finish dates for all activities as appropriate.
 - 3. List of materials and/or equipment delivered for which payment is requested and an original paid invoice verifying cost.
 - 4. Identification of processing errors, if any, on previous update report.
 - 5. Identification of activities which are affected by proposed Change Orders issued during the update period (Network Window).
 - 6. Resolution of conflict between actual work progress and schedule logic. If out of sequence activities developed in schedule due to actual construction progress, submit revisions to schedule logic to conform to current job status and direction.
 - 7. Owner will review updated information and meet with Contractor each month to ascertain status of Work.
 - 8. Progress payments pursuant to the Agreement will be approved only after receipt of timely, accurately updated Schedule and Schedule of Values and will be based on the update of the Schedule of Values. Contractor and Owner will jointly review progress and agree upon quantity of work completed prior to Contractors submittal of revised Schedule of Values and invoice.
- G. Contract Schedule Revisions:
- 1. If there are significant changes in plan of construction from that shown in accepted Construction Schedule, as determined by Owner, Contractor shall, within ten working days after receiving notice, submit a revised schedule to Owner for approval.

2. Submitting Project Construction Schedule and updates, if applicable, shall be considered as a necessary portion of Work; therefore, partial payments will not be made until requirement for acceptable schedules has been satisfied.
3. Acceptance of any schedule submitted shall not be construed to assign responsibility of performance or contingencies to Owner, or relieve Contractor of responsibility to adjust forces, equipment, and/or work schedule as may be necessary to ensure completion of Work within prescribed Contract Time period.

1.04 SCHEDULE OF VALUES SUBMITTAL

- A. Submit Schedule of Values to Owner for review within 10 days after Contract execution.
 1. Finalize at least 10 days before the first application for a Progress Payment.
 2. Provide cost breakdown of the various parts of the Work aggregating the total sum of the Contract.
 3. Make out in required detail and support by evidence of correctness.
 4. Owner will coordinate and approve Schedule of Values format.
 5. Include itemized descriptions, quantities, and value of all work included in each activity in the Construction Schedule.
- B. Use Schedule of Values as a basis for applications for monthly Progress Payments, unless later found to be in error.
- C. When applying for each Progress Payment, submit a statement based upon this Schedule of Values.

1.05 SHOP DRAWING SUBMITTALS

- A. Furnish to Engineer for review, five prints of each shop drawing.
 1. The term "shop drawings" shall include detail design calculations, fabrication and installation drawings, lists, graphs, and operating instructions
 2. Unless otherwise required, submit shop drawings a time sufficiently early to allow review by Engineer and to accommodate rate of construction progress under the Contract.
- B. Within fifteen calendar days after receipt of prints Engineer will return prints of each drawing to Contractor with comments noted.
 1. It is considered reasonable that Contractor shall make a complete and acceptable submittal by the second submission of drawings.
 2. Owner reserves the right to withhold monies due Contractor to cover additional costs of Engineer's review beyond second submission.

- C. If three prints of drawing are returned to Contractor marked NO EXCEPTIONS TAKEN, a formal revision of drawing will not be required.
- D. If three prints of drawing are returned to Contractor marked MAKE CORRECTIONS NOTED, a formal revision of drawing will not be required.
- E. If one print of drawing is returned to Contractor marked AMEND-RESUBMIT or REJECTED-RESUBMIT, Contractor shall revise drawing and resubmit eight copies of revised drawing to Engineer for review.
- F. Fabrication of an item shall not be commenced before Engineer has reviewed pertinent shop drawings and returned copies to Contractor marked NO EXCEPTIONS TAKEN or MAKE CORRECTIONS NOTED.
 - 1. Revisions indicated on shop drawings shall be changes necessary to meet requirements or Drawings and Specifications and shall not be taken as basis of claims for extra work.
 - 2. Contractor shall have no claim for damages or extension of time due to delay resulting from Contractor's having to make required revisions to shop drawings (unless review by Engineer of drawings is delayed beyond a reasonable period of time and unless the Contractor can establish that Engineer's delay in review actually resulted in delay in Contractor's construction schedule).
 - 3. Review of drawings by Engineer will be limited to checking for general agreement with Specifications and Drawings, and shall in no way relieve Contractor of responsibility for errors or omissions contained therein, nor shall such review operate to waive or modify any provision contained in Specifications or Drawings.
- G. Engineer's review of shop drawing Submittals shall not relieve Contractor of entire responsibility for correctness of details and dimensions.
 - 1. Contractor shall assume all responsibility and risk for misfits due to errors in Contractor submittals.
 - 2. Contractor shall be responsible for:
 - a. Dimensions and design of adequate connections and details.
 - b. Fabricating dimensions.
 - c. Quantities of materials.
 - d. Applicable code requirements.
 - e. Other Contract requirements.
- H. Engineer shall have authority to reject any product upon completion of review of suppliers' Submittals in regard to proof of acceptability of the product

1.06 CERTIFICATES OF INSPECTION

- A. When specified in individual specification sections, submit inspection certification by appropriate entity to Owner in quantity specified.
- B. Certificates shall be acceptable to Owner.
- C. Indicate Work conforms to or exceeds specified requirements. Submit supporting reference data, affidavits, and certifications as appropriate.

1.07 SPARE PARTS LISTS SUBMITTAL

- A. Furnish to Owner eight identical sets of spare parts information for instrumentation, mechanical, and electrical equipment.
- B. Include current list price of each spare part.
- C. Limit list to those spare parts which each manufacturer recommends be maintained by Owner in inventory at the site.
- D. Each manufacturer or supplier shall indicate name, address, and telephone number of nearest outlet of spare parts to facilitate Owner in ordering.
- E. Cross-reference spare parts lists to equipment numbers designated in Construction Documents.
- F. Bind spare parts lists in standard size, 3-ring, loose leaf, vinyl plastic hard cover binders suitable for bookshelf storage. Binder ring size shall not exceed 2.5 inches.

1.08 MIX DESIGN SUBMITTALS

- A. Prepare Portland cement concrete and asphalt concrete mix designs.
 - 1. Determine exact proportions of materials to be used for different parts of Work, in conformance with Drawings and Specifications.
 - 2. Submit to Engineer for review prior to use in Work
- B. Samples for mix design shall represent existing stockpile.
 - 1. Mix designs "copied" from previous projects will not be accepted unless the existing stockpile aggregate is tested to assure conformity.
 - 2. Any stockpile additive, binder or cement source location and/or type of material change will require a new mix design.

1.09 OMISSIONS OR ERRORS IN SUBMITTED DATA

- A. Pay costs involved in correcting omissions or errors in submitted data, including failure to make timely submittal.

- B. Pay costs involved in correcting omissions or errors in execution of correctly submitted information.
- C. Costs shall include additional compensation due to Owner and Engineer due to additional services necessitated by the change.

PART 2 PRODUCTS

Not used.

PART 3 EXECUTION

Not used.

END OF SECTION

SECTION 01400

QUALITY CONTROL

PART 1 GENERAL

1.01 SECTION INCLUDES

- A. Quality assurance - control of installation.
- B. Tolerances.
- C. Inspecting and testing laboratory services.
- D. Manufacturers' field services and reports.
- E. Inspection at place of manufacture.

1.02 QUALITY ASSURANCE - CONTROL OF INSTALLATION

- A. Monitor quality control over suppliers, manufacturers, products, services, site conditions, and workmanship, to produce Work of specified quality.
- B. Comply with manufacturer's instructions, including each step in sequence.
- C. Should manufacturers' instructions conflict with Construction Documents, request clarification from Engineer before proceeding.
- D. Comply with specified standards as minimum quality for the Work except where more stringent tolerances, codes or specified requirements indicate higher standards or more precise workmanship.
- E. Perform work by persons qualified to produce workmanship of specified quality.
- F. Secure Products in place with positive anchorage devices designed and sized to withstand stresses, vibration, physical distortion, or disfigurement.

1.03 TOLERANCES

- A. Monitor tolerance control of installed Products to produce acceptable Work. Do not permit tolerances to accumulate.
- B. Comply with manufacturers' tolerances. Should manufacturers' tolerances conflict with Construction Documents, request clarification from Engineer before proceeding.
- C. Adjust Products to appropriate dimensions; position before securing Products in place.

1.04 INSPECTING AND TESTING LABORATORY SERVICES

- A. Owner will appoint, employ, and pay for specified services of an independent firm to perform inspecting and testing.
- B. The independent firm will perform inspections, tests, and other services specified in individual specification sections and as required by Engineer and Owner.
- C. Inspecting, testing and source quality control may occur on or off the project site. Perform offsite inspecting or testing as required by Engineer or Owner.
- D. Reports will be submitted by the independent firm to Engineer, in duplicate, indicating observations and results of tests and indicating compliance or noncompliance with Construction Documents.
- E. Cooperate with independent firm; furnish samples of materials, design mix, equipment tools, storage, safe access, and assistance by incidental labor as required.
 - 1. Notify Engineer and independent firm 24 hours prior to expected time for operations requiring services.
 - 2. Make arrangements with independent firm and pay for additional samples and tests required for Contractors use.
- F. Testing and inspecting does not relieve Contractor to perform Work to Contract requirements.
- G. Retesting required because of non-conformance to specified requirements shall be performed by the same independent firm on instructions by Engineer. Payment for retesting will be charged to Contractor by deducting inspecting or testing charges from the Contract Price.

1.05 MANUFACTURERS' FIELD SERVICES AND REPORTS

- A. When specified in individual specification sections, require material or Product suppliers or manufacturers to provide qualified staff personnel to observe site conditions, conditions or surfaces and installation, quality of workmanship, start-up of equipment, and test, adjust and balance of equipment as applicable, and to initiate instructions when necessary.
- B. Submit qualifications of observer to Engineer 30 days in advance of required observations.
- C. Report observations and site decisions or instructions given to applicators or installers that are supplemental or contrary to manufacturers written instructions.
- D. Submit report in duplicate within 30 days of observation to Engineer for information.

1.06 INSPECTION AT PLACE OF MANUFACTURE

- A. Products, materials, and equipment shall be subject to inspection by Engineer at place of manufacture.

- B. Presence of Engineer at place of manufacture shall not relieve Contractor of responsibility for finishing products, materials, and equipment which comply with requirements of the Construction Documents.
- C. Compliance is a duty of Contractor which shall not be avoided by any act or omission on the part of Engineer.

PART 2 PRODUCTS

Not used.

PART 3 EXECUTION

Not used.

END OF SECTION

SECTION 01505

MOBILIZATION

PART 1 GENERAL

1.01 DESCRIPTION

- A. Mobilization shall include obtaining permits; moving plant and equipment onto site; furnishing and erecting plants, temporary buildings, and other construction facilities, as required for the proper performance and completion of the Work
- B. Mobilization shall include the following principal items:
 - 1. Moving onto the site of plant and equipment required for first month operations including field office for Owner.
 - 2. Installing temporary construction power, wiring, and lighting facilities.
 - 3. Establishing fire protection system.
 - 4. Developing construction water supply.
 - 5. Providing onsite communication facilities.
 - 6. Providing onsite sanitary facilities and potable water facilities as specified.
 - 7. Arranging for and erection of work and storage yard.
 - 8. Obtaining required permits.
 - 9. Posting OSHA required notices and establishment of safety programs.
 - 10. Having the superintendent at the jobsite full time.
 - 11. Submitting Preliminary Construction Schedule.

PART 2 PRODUCTS

Not used.

PART 3 EXECUTION

Not used.

END OF SECTION

SECTION 01515

TEMPORARY UTILITIES AND CONSTRUCTION FACILITIES

PART 1 GENERAL

1.01 SUMMARY

- A. Provide plant and equipment adequate for performance of the work within the time specified.
- B. Keep plant and equipment in satisfactory operating condition, capable of safely and efficiently performing the required Work, and subject to inspection and approval by Owner or Engineer at any time during the Work.
- C. Nothing in this section is intended to limit types and amounts of temporary work required, and no omission from this section will be recognized as an indication by Owner that such temporary activity is not required for successful completion of Work and compliance with requirements of Construction Documents.
- D. Conform to applicable requirements of OSHA Standards for Construction.
- E. Dispose of temporary construction facilities when no longer needed or at completion of the Contract, unless otherwise requested in writing by Owner or specified. Repair damage caused by the installations.

1.02 TEMPORARY ELECTRICITY

- A. Temporary connections for stand-by power shall be subject to approval of Owner.

1.03 TEMPORARY WATER SERVICE

- A. Temporary water service for construction and sanitary needs will be provided by the Contractor throughout the construction period.
 - 1. Contractor will provide facilities necessary to obtain water required for Work.
 - 2. Owner will obtain necessary permits and pay any utility service provider fees in force for construction water.
- B. Potable Water
 - 1. Contractor will furnish drinking water onsite during construction which is bottled water or water furnished in approved metal dispensers.
 - 2. Post notices conspicuously throughout the site warning personnel that piped water may be contaminated.
- C. Water Connections:

1. Do not make connection to, or draw water from, any fire hydrant or pipeline without first obtaining permission of the authority having jurisdiction over the use of fire hydrant or pipeline and from the agency owning the affected water system.
2. For each such connection made, first attach to fire hydrant or pipeline a valve and a meter, if required by the authority, of a size and type acceptable to authority and agency.

D. Removal of Water Connections:

1. Before final acceptance of Work, entirely remove temporary connections and piping.
2. Restore affected improvements to original condition, or better, to satisfaction of Owner and to agency owning affected utility.

E. The City will provide water for construction purposes.

1.04 TEMPORARY SANITARY FACILITIES

A. Comply with sanitary requirements prescribed by local or state health departments.

B. Sanitary and Other Organic Wastes:

1. Establish regular collection of sanitary and organic wastes.
2. Dispose of wastes and refuse from sanitary facilities provided by Contractor, or organic material wastes from sources related to Contractor's operations, away from site in a manner satisfactory to Owner and Engineer and in accordance with all laws and regulations.

C. Toilet Facilities:

1. Provide fixed or portable chemical toilets wherever needed for use of employees.
2. Toilets at construction job sites shall conform to requirements of Part 1926 of OSHA Standards for Construction.

PART 2 PRODUCTS

Not used.

PART 3 EXECUTION

Not used.

END OF SECTION

SECTION 01530

PROTECTION OF EXISTING FACILITIES

PART 1 GENERAL

1.01 SUMMARY

- A. Protect existing utilities and improvements not designated for removal.
- B. Restore damaged or temporary relocated utilities and improvements to a condition equal to or better than they were prior to such damage or temporary relocation.
- C. Verify exact locations and depths of utilities shown and make exploratory excavations of utilities that may interfere with Work.
 - 1. Perform exploratory excavations as soon as practicable after award of Contract and in sufficient time in advance of construction to avoid possible delays to Work.
 - 2. When exploratory excavations show utility location as shown to be in error, notify Engineer.
- D. The number of exploratory excavations required shall be sufficient to determine alignment and grade of existing utilities.

1.02 RIGHTS-OF-WAY

- A. Access to lands or rights-of-way for the Work will be provided by Owner as shown on the Drawings.
 - 1. Nothing contained in the Construction Documents shall be interpreted as giving Contractor exclusive occupancy of the lands or rights-of-way provided.
 - 2. Additional lands or rights-of-way required for construction operations shall be provided by Contractor at his own expense.
- B. Do not enter nor occupy with men, equipment, or materials, any lands outside the rights-of-way or easements shown without meeting the following requirements:
 - 1. Furnish to Owner, prior to use of any other public or private properties by Contractor in performance of Work, written authorization by the property owner for use of such property by Contractor.
 - 2. Prior to acceptance of Work by Owner, furnish Owner with written evidence, acceptable to Owner, releasing Contractor from liability to the property owner for the use of such property by Contractor.
 - 3. Take precautions necessary to preserve private and public property in immediate area of work site.

4. Total liability shall be assumed by Contractor for damage to private and/or public property during the prosecution of Work.
5. Upon completion of Work all private and public property shall be, as a minimum, restored to its conditions existing prior to the commencement of work thereon.

1.03 PROTECTION OF STREET OR ROADWAY MARKERS

- A. Do not destroy, remove, or otherwise disturb existing survey markers or other existing street or roadway markers without proper authorization.
- B. Start no pavement breaking or excavation until survey or other permanent marker points that will be disturbed by the construction operations have been properly referenced for easy and accurate restoration.
- C. Notify Engineer of the time and location that work will be done, sufficiently in advance of construction to avoid delay due to waiting for survey points to be satisfactory referenced for restoration.
- D. Survey markers or points disturbed by Contractor without proper authorization by Owner, will be restored by Owner at Contractor's expense after Work has been completed.

1.04 GENERAL RESTORATION OF PAVEMENT

- A. Replace paved areas, including asphaltic concrete berms cut or damaged during construction, with similar materials and of equal thickness to match the existing adjacent undisturbed areas, except where specific resurfacing requirements have been called for in the Contract Documents or in the requirements of the agency issuing the permit.
- B. Temporary and permanent pavement shall conform to the requirements of the owner of the affected pavement.
- C. Pavements subject to partial removal shall be neatly saw-cut in straight lines.

1.05 CONSTRUCTION INTERFERENCES

- A. Contractor's responsibilities regarding existing utilities and construction interferences shall be in accordance with Standard Specifications for Public Works' Construction, Nye County Area, Nevada, and NDOT with the following additional provisions.
- B. Construction interferences include:
 1. Utility or service connections within the limits of excavation or over-excavation required for the Work
 2. Utility or service connections located in the space which will be required by the Work.
 3. Utility or service connections required to be disturbed or removed to permit construction as specified under the Contract.

- C. Disturb or remove connections only with approval of owner and following notification to owner of interfering utility or service connection.
- D. Promptly reconstruct utility or service connections removed or otherwise disturbed in original or other authorized location in a condition at least as good as prior to such removal or disturbance, subject to the inspection of utilities' owners.
- E. Contractor's responsibility to remove or replace shall apply even in if damage or destruction occurs after backfilling.
- F. Immediately notify owner of utility if service connection damage or destruction occurs or is discovered.
- G. During the performance of the Work, the owner of any utility affected by the Work shall have the right to enter when necessary upon any portion of the Work for the purpose of maintaining service and of making changes in or repairs to the utility.
- H. Contractor shall not be held responsible for failure to complete the Work on time to the extent that such delay was caused by failure of the owner or of the agency having jurisdiction over the utility or service connection to authorize or otherwise provide for its removal, relocation, protection, support, repair, maintenance, or replacement.
- I. Exercise extreme care not to damage existing utilities and/or new and existing facilities which do not physically constitute a construction interference.
 - 1. Use equipment of such weights throughout construction operations so that existing buried utilities and/or new and existing facilities are not damaged by excessive loadings.
 - 2. Contractor shall be responsible for costs of repair and/or replacement of new or existing facilities damaged by construction operations, as determined by Owner.
- J. Contact "CALL BEFORE YOU DIG" not less than 48 hours prior to starting any excavation. Notify by telephone and comply with all instructions received; the toll free number is 1-800-227-2600 or 811.
 - 1. All utility companies may not be members of the USA System and, therefore, not automatically contacted by the above referenced telephone number.
 - 2. Contractor shall be responsible for making himself aware of utility company facilities not reported by the USA System, and shall bear any and all damages stemming from repair or delay costs or any other expenses resulting from the unanticipated discovery of underground utilities.
 - 3. Notify the pertinent utilities at least two working days in advance of commencement of work at site, to examine the construction site and mark the location of the utilities' respective facilities. Verify that each utility has responsibly responded to the notification.

PART 2 PRODUCTS

Not used.

PART 3 EXECUTION

Not used.

END OF SECTION

SECTION 01535

SAFETY

PART 1 GENERAL

1.01 SUMMARY

- A. Nothing contained in this section is intended to limit the types and amounts of safety precautions required.
- B. No omission from this section will be recognized as an indication by the Owner that such safety precautions are not required for successful completion of the Work and compliance with requirements of Contract Documents.

1.02 SAFETY PROTECTION

- A. Prior to starting and during progress of the Work, prevent hazards to personnel and property, including that of the Owner, Engineer, subcontractors, separate contractors, the neighborhood, and the public.
- B. Provide for proper care, safety, and protection of materials, installed work, personnel, and equipment.
- C. Precautions taken for safety and protection shall not relieve Contractor from liability due to accidents or any other cause.

1.03 COMPLIANCE WITH SAFETY PROGRAM

- A. Implement and enforce a safety program consistent with the needs and objectives of the Owner.
- B. Comply with the requirements of federal, state, and local regulations governing safety.
- C. Provide personal protective equipment as defined by state and federal laws. Such equipment shall be worn by employees (hard hats, eye protection, etc.)
- D. Hold weekly safety meetings with subcontractors and report items discussed to the Owner and Engineer on a weekly basis.
- E. Lower tier subcontractors shall conduct weekly toolbox meetings and weekly safety - inspections of its areas and equipment. Equipment so required by law (such as cranes and cables) shall be inspected dally.
- F. Thoroughly investigate accidents to the degree satisfactory to the Owner.
- G. Submit weekly written reports to the Owner for the following items:
 - 1. Safety meetings.

2. Area and equipment inspection
3. Accident investigations and statistics.

PART 2 PRODUCTS

Not used.

PART 3 EXECUTION

Not used.

END OF SECTION

SECTION 01550

ACCESS ROADS AND PARKING AREAS

PART 1 GENERAL

1.01 SUMMARY

- A. Furnish and maintain vehicular access to the site and within the site to provide uninterrupted access:
 - 1. To temporary construction facilities.
 - 2. To storage and work areas which are for use by persons and equipment involved in the construction of this and adjacent projects.
 - 3. For access by emergency vehicles.

1.02 TEMPORARY CROSSINGS

- A. Wherever necessary or required for convenience of the public or individual residents at street or highway crossings, private driveways, or elsewhere, provide suitable temporary bridges or steel plates over unfilled excavations.
 - 1. Exceptions require written consent of individuals or authorities concerns to omit such temporary bridges or steel plates and delivery of the written consent to Owner prior to excavation.
 - 2. Maintain bridges or steel plates in service until access is provided across backfilled excavation.
 - 3. Conform temporary bridges or steel plates for street and highway crossings to requirements of the authority having jurisdiction in each case; adopt designs furnished by the authority for the bridges or steel plates or submit designs to the authority for approval, as may be required.
- B. Street Use:
 - 1. Nothing herein shall be construed to entitle Contractor to exclusive use of any public street, alleyway, or parking area during the performance of the Work.
 - 2. Conduct operations to not interfere unnecessarily with authorized work of utility companies or other agencies in the streets, alleyways, or parking areas.
 - 3. Close no street to the public without first obtaining permission of Owner and proper governmental authority.

4. Where excavation is being performed in primary streets or highways, one lane in each direction shall be kept open to traffic at all times unless otherwise provided or shown.
 5. Provide toe boards to retain excavated material if required by Owner or agency having jurisdiction over the street or highway.
 6. Keep fire hydrants on or adjacent to the Work accessible to fire-fighting equipment at all times.
 7. Make temporary provisions to assure the use of sidewalks and proper functioning of gutters, sewer inlets, and other drainage facilities.
- C. Street Closure: If closure of any street is required during construction, make formal application for street closure to authority having jurisdiction at least 30 days prior to the required street closure in order to determine necessary sign and detour requirements.

1.03 ACCESS ROADS

- A. Provide access roads that may be required as approved by Owner.
- B. Keep roads clean of construction spillage and debris at all times.
- C. Repair damages caused to roads or adjacent property by Contract related construction vehicles by replacing damaged pavement, landscaping, concrete and other adjacent property to match new or existing construction.
- D. Locate access roads, drives, walks and parking facilities to provide uninterrupted access to construction offices, mobilization, work and storage areas, and other areas required for execution of the Contract.
- E. Use, maintain, and repair local public roads in strict conformance with local and state codes, regulations and ordinances at no expense to Owner.

1.04 CONSTRUCTION PARKING

- A. Provide parking facilities adequate for the needs of project personnel, as approved by Owner.
- B. Maintain parking area for construction vehicles.

1.05 CONTRACTOR'S WORK AND STORAGE AREA

- A. Make arrangements for offsite storage, staging, or shop areas which may be necessary for proper execution of the Work.

PART 2 PRODUCTS

Not used.

PART 3 EXECUTION

Not used.

END OF SECTION

SECTION 01560

TEMPORARY ENVIRONMENTAL CONTROLS

PART 1 GENERAL

1.01 SUMMARY

- A. Provide and maintain control over environmental conditions at the construction site and related areas under Contractor's control.
- B. Remove physical evidence of temporary facilities upon completion of the Work.
- C. Section includes:
 - 1. Dust Control.
 - 2. Water Control.
 - 3. Debris Control.
 - 4. Pollution Control.
 - 5. Explosives and Blasting.
 - 6. Barriers.
 - 7. Protection of Installed Work.
 - 8. Security.
 - 9. Chemicals.

PART 2 PRODUCTS

Not used.

PART 3 EXECUTION

3.01 DUST CONTROL

- A. Provide positive methods and application of dust control materials as necessary to minimize dust from construction operations.
- B. Provide positive means to prevent airborne dust from disbursing into the atmosphere. See Article 3.05, this section.

3.02 WATER CONTROL

- A. Control surface water and prevent damage to the Project, the site, and adjoining properties.
- B. Furnish, place, and maintain supports and shoring required for the sides of the excavations.
- C. Properly dispose of onsite storm drainage water and divert offsite drainage to prevent flooding, erosion, or other damage to any portion of the site or to adjoining areas.

3.03 DEBRIS CONTROL

- A. Keep all areas under Contractor's control free from extraneous debris; at all times keep work area in a neat, clean, and safe condition.
- B. Initiate and maintain a specific program to prevent accumulation of debris at the site, in storage and parking areas, and along access roads and haul routes, as follows:
 - 1. Provide containers for deposit of debris.
 - 2. Prohibit overloading of trucks to prevent spillage on access and haul routes.
 - 3. Perform periodic inspections to enforce these requirements.
- C. Schedule periodic collection and disposal of debris and provide additional collection and disposal of debris whenever the periodic schedule is inadequate to prevent accumulation.
- D. If Contractor fails to clean up as provided in Construction Documents, Owner may do so and cost thereof will be charged to Contractor.

3.04 POLLUTION CONTROL

- A. Prevent contamination of soil, water or atmosphere by the discharge of noxious substances from construction operations, including equipment personnel and emergency measures required to contain any spillage, and to remove contaminated soils or liquids.
 - 1. After obtaining proper approvals, excavate and dispose of contaminated earth offsite, and replace with suitable compacted fill and topsoil.
- B. Take special precautions to prevent harmful substances from entering public waters.
 - 1. Prevent disposal of wastes, effluents, chemicals or other substances adjacent to washes, or in sanitary or storm sewers.
- C. Control atmospheric pollutants to prevent toxic concentrations of chemicals, and to prevent harmful dispersal of pollutants into the atmosphere.
- D. This project is located in Nye County, Nevada.
 - 1. Contact the State Health Bureau (Air Pollution Control Division) regarding special considerations concerning air quality requirements in Nye County.

2. Compliance with all rules, regulations, special stipulations and laws pertaining to air quality shall be Contractor's responsibility and the cost thereof shall be considered in the Contract lump sum price.

E. Applications for Operating Permits and for Authority to Construct facilities for extracting and processing of onsite materials shall be the Contractor's responsibility.

3.05 EXPLOSIVES AND BLASTING

A. The use of explosives on the Work will not be permitted.

3.06 BARRIERS

A. Provide barriers to prevent unauthorized entry to construction areas and to protect existing facilities and adjacent properties from damage from construction operations.

B. Provide protection for plant life designated to remain. Replace damaged plant life.

C. Protect non-owned vehicular traffic, stored materials, site and structures from damage.

3.07 PROTECTION OF INSTALLED WORK

A. Protect installed Work and provide special protection where specified in individual specification sections.

B. Provide temporary and removable protection for installed Work Control activity in immediate work area to prevent damage.

C. Prohibit traffic from landscaped areas.

3.08 SECURITY

A. Protect work, existing premises, and Owner operations from theft, vandalism, and unauthorized entry.

B. Initiate security program in coordination with Owner's existing security system upon receipt of notice to proceed.

3.09 CHEMICALS

A. All chemicals used during project construction or furnished for project operation (i.e., defoliant, soil sterilant, herbicide, pesticide, disinfectant, polymer, reactant or of other classification) shall show approval of either the U.S. Environmental Protection Agency or the U.S. Department of Agriculture.

1. Use of chemicals and disposal of residues shall be in strict accordance with the printed instructions of the manufacturer.

END OF SECTION

SECTION 01600

MATERIALS AND EQUIPMENT

PART 1 GENERAL

1.01 DEFINITIONS

- A. The word "Products" is defined to include purchased items for incorporation into the Work, regardless of whether specifically purchased for the project or taken from Contractor's stock of previously purchased products.
- B. The word "Materials" is defined as products which must be substantially cut, shaped, worked, mixed, finished, refined, or otherwise fabricated, processed, installed, or applied to form units of work.
- C. The word "Equipment" is defined as products with operational parts, regardless of whether motorized or manually operated, and particularly including products with service connections (wiring, piping, and other like items).
- D. Definitions in this Article are not intended to negate the meaning of other terms used in Construction Documents, including "specialties," "Systems," "Structure," "accessories," "special construction," and similar terms, which are self-explanatory and have recognized meanings in the construction industry.

1.02 QUALITY ASSURANCE

- A. Source limitations: To the greatest extent possible for each unit of work, provide products, materials or equipment of a singular generic kind from a single source.
- B. Compatibility of Options:
 - 1. Where more than one choice is available as options for Contractor's selection of a product, material, or equipment, select an option which is compatible with other products, materials, or equipment already selected.
 - 2. Compatibility is a basic general requirement of product/material selections.
- C. Do not use materials and equipment removed from existing premises, except as specifically permitted by the Construction Documents.
- D. Provide interchangeable components of the same manufacturer, for similar components.

1.03 PRODUCT DELIVERY-STORAGE-HANDLING

- A. Deliver, handle, and store products in accordance with supplier's written recommendations and by methods and means which will prevent damage, deterioration, and loss, including theft.

1. Control delivery schedules to minimize long- term storage of products at site and overcrowding of construction spaces.
2. Provide delivery/installation coordination to ensure minimum holding or storage times for products recognized to be flammable, hazardous, easily damaged, or sensitive to deterioration, theft, and other sources of loss.

1.04 TRANSPORTATION AND HANDLING

- A. Transport products to avoid product damage and delivery in undamaged condition in supplier's unopened containers or packing, dry.
- B. Provide equipment and personnel to handle products, materials, and equipment, including those provided by Owner, to prevent soiling and damage.

1.05 STORAGE AND PROTECTION

- A. Store products in accordance with suppliers written instructions, with seals and labels intact and legible.
 1. Store sensitive products in weather- tight enclosures.
 2. Maintain temperature and humidity ranges within tolerances required by supplier's written instructions.
- B. For exterior storage or fabricated products, place on sloped supports above ground.
 1. Cover products subject to deterioration with impervious sheet covering.
 2. Provide ventilation to avoid condensation.
- C. Store loose granular materials on solid surfaces in a well-drained area and prevent from mixing with foreign matter.
- D. Arrange storage to provide access for inspection. Periodically inspect products to assure that products are undamaged and maintained under required conditions.
- E. Arrange storage to provide access for maintenance of stored items.

1.06 MAINTENANCE OF STORAGE

- A. Periodically inspect stored products on scheduled basis. Maintain a log of inspections and make log available to Owner on request.
- B. Verify that storage facilities comply with supplier's product storage requirements.
- C. Verify that supplier required environmental conditions are maintained continually.
- D. Verify that surfaces of products exposed to elements are not adversely affected and that weathering of finishes is acceptable under requirements of Construction Documents.

PART 2 PRODUCTS

Not used.

PART 3 EXECUTION

Not used.

END OF SECTION

SECTION 01630

PRODUCT OPTIONS AND SUBSTITUTIONS

PART 1 GENERAL

1.01 REQUIREMENTS INCLUDED

- A. Contractor's selection of products.
- B. Requests for substitution of products.

1.02 SELECTION OF PRODUCTS

- A. Base bid on products, materials, or systems specified to establish the standard of quality required and to provide a uniform basis for evaluating bids.
- B. Products Specified by Naming Only One Manufacturer:
 - 1. Include that manufacturer in base bid.
- C. Products Specified by Naming One or More Manufacturers:
 - 1. Include first one named in base bid unless a particular section states that any manufacturers listed in that Section may be used in base bid.
- D. When product or manufacturer's names are not specified, provide products, materials, or systems in accordance with performance requirements and install in accordance with material manufacturer's recommendations.
- E. "Or Equal":
 - 1. Where phrases "or equal" or "or approved equal" occur in Construction Documents, do not assume that the products, materials, or system will be approved as equal (even if approved for use on previous projects) until the item has been specifically approved for this work by Engineer.
 - 2. Decision of Engineer shall be final.

1.03 LIMITATIONS ON SUBSTITUTIONS

- A. Substitutions will be considered only when listed on the form provided at the end of this Section (Substitution Request Form).
- B. Only proposed substitutions of Successful Bidder will be reviewed, providing the following procedures have been adhered to:
 - 1. List on Substitution Request Form as specified in Paragraph A.

2. Completely execute Substitution Request Form for each product with substantiating data attached, and signed by authorized representative of Contractor. Submit in quadruplicate.
 3. Deliver requests to Engineer's office within seven calendar days from date of Notice of Award. Late submittals will not be reviewed.
- C. Subsequent requests will be considered in case of product unavailability.
1. Submit a letter to this effect written by the manufacturer accompanied by the completed Substitution Request Form. If, in the opinion of the Engineer, any product specified:
 - a. Cannot be delivered during progress of Work.
 - b. Will no longer be available during progress of Work, or
 - c. If quality of material, as specified, no longer meets Specifications, Engineer will specify a substitute. The material cost differential (credit or extra) between the specified material and the "substitute" will be reflected in a Change Order to Contractor.
 - d. Request for subsequent substitutions may be submitted no later than 30 days after Notice to Proceed is issued.
- D. Substitutions will not be considered when indicated on shop drawings or product data submittals, when requested directly by subcontractor or supplier, or when acceptance will require substantial revisions of Construction Documents.
- E. Substitute products shall not be ordered or installed without written acceptance.
- F. Only one request for substitution for each specified product will be considered. When substitution is not accepted, provide specified product.
- G. Approval, or rejection, of a request for a Substitution will be based on Engineer's opinion, with concurrence by Owner, as to adaptability, durability, quality, aesthetics, and Contract Amount change, when compared to the specified or noted items.

1.04 REQUESTS FOR SUBSTITUTIONS

- A. Identify product by specification section and article numbers. Provide manufacturer's name and address, trade name of product, and model or catalog number. List fabricators and suppliers as appropriate.
- B. Attach product data as specified in Section 01300.
- C. List similar projects using product, dates of installation, and names of Engineers and Owners.
- D. Give itemized comparison of proposed substitution with specified product, listing variations.
- E. Give quality and performance comparison between proposed substitution and the specified product.

- F. Give cost data comparing proposed substitution with specified product, and amount of net change to Contract Amount.
- G. List availability of maintenance services and replacement materials.
- H. State effect of substitution on construction schedule, and changes required in other work or products.

1.05 CONTRACTOR REPRESENTATION

- A. Request for substitution constitutes a representation that Contractor has investigated proposed product and has determined that it is equal to or superior in all respects to specified product. In addition, Contractor:
 - 1. Will provide same warranty for substitution as for specified product.
 - 2. Will coordinate installation of accepted substitute, making such changes as may be required for Work to be complete in all respects.
 - 3. Certifies that cost data presented is complete and includes all related costs under this Contract.
 - 4. Waives claims for additional costs related to substitution which may later become apparent.

1.06 SUBMITTAL PROCEDURES

- A. Submit four copies of request for substitution.
- B. After award of Contract, Engineer will notify Contractor, in writing, of status of requested substitutions with 10 days.
- C. For accepted products, submit shop drawings, product data and samples under provisions of Section 01300.

PART 2 PRODUCTS

Not used.

PART 3 EXECUTION

Not used.

END OF SECTION

SUBSTITUTION REQUEST FORM

DATE: _____ PROJECT TITLE: _____

PROJECT NUMBER: _____ LOCATION: _____

NAME AND ADDRESS OF CONTRACTOR:

SUBMITTED FOR REVIEW TO:

PLEASE CONSIDER FOR APPROVAL THE FOLLOWING PRODUCT OR SYSTEM AS AN "APPROVED EQUAL" SUBSTITUTION IN ACCORDANCE WITH THE PROVISIONS OF THE CONTRACT DOCUMENTS.

* * * * *

NAME AND DESCRIPTION OF SPECIFIED PRODUCT OR SYSTEM:

SPECIFICATION DIVISION _____ SECTION _____ PAGE(S) _____

DRAWINGS NO(S). _____ DETAIL OR SECTION NO(S) _____

NAME AND DESCRIPTION OF SUBMITTAL FOR SUBSTITUTION:

NAME, ADDRESS, AND TELEPHONE NUMBER OF MANUFACTURER:

NAME, ADDRESS AND TELEPHONE NUMBER OF VENDOR:

* * * * *

REASON(S) FOR NOT GIVING PRIORITY TO SPECIFIED ITEM:

1. SUBSTITUTION AFFECTS OTHER MATERIALS OR SYSTEMS:
___ YES ___ NO

2. SUBSTITUTION REQUIRES DIMENSIONAL REVISION OR REDESIGN OF
STRUCTURE: ___ YES ___ NO

(If YES, for 1 and/or 2 above, attach complete data)

3. SAVING OR CREDIT TO OWNER FOR ACCEPTING SUBSTITUTE (even dollar)
\$ _____ (In words: _____ dollars)

4. ATTACH DATA FURNISHED FOR EVALUATION OF SUBSTITUTION:
___ CATALOG, ___ DRAWINGS, ___ SAMPLES, ___ TESTS, ___ REPORTS
___ OTHER.

5. MANUFACTURER'S GUARANTEES OF THE SUBSTITUTE VS SPECIFIED ITEM IS:
___ SAME ___ DIFFERENT (Explain on Attachment)

THE UNDERSIGNED HEREBY CERTIFIES THAT THIS SUBSTITUTION HAS BEEN FULLY
CHECKED AND COORDINATED WITH THE CONTRACT DOCUMENTS.

CONTRACTOR: _____ BY: _____

ADDRESS: _____ TITLE: _____

_____ PHONE: () _____

_____ ACCEPTED _____ ACCEPTED AS NOTED _____ NOT ACCEPTED

_____ RECEIVED TOO LATE DATE RECEIVED: _____

DATE OF ACTION: _____ BY: _____

FOR ENGINEER OF RECORD

SECTION 01710

CLEANING

PART 1 GENERAL

1.01 SECTION INCLUDES

- A. Cleaning during progress of the Work and at completion of the Work, as required by conditions of the Contract.

1.02 DISPOSAL REQUIREMENTS

- A. Conduct cleaning and disposal operations to comply with codes, ordinances, regulations, and anti-pollution laws.

1.03 CLEANING DURING CONSTRUCTION

- A. Contractor shall be responsible for Contractor's own waste, debris and cleanup on a regular basis and for maintaining a clean environment
- B. After due notice, Owner will clean up areas of Contractor's work not cleaned up and will charge Contractor the cost thereof, which charge will be deducted from payments due or to become due Contractor.
- C. Remove waste materials, debris and rubbish from the site periodically and dispose of it at legal disposal areas away from the site.
- D. Notwithstanding the conditions stated above, the Contractor shall be solely responsible for the collection and removal of all hazardous material.
- E. Contractor shall execute periodic cleaning to keep the Work, the site and adjacent properties free from accumulations of waste materials, rubbish and wind blown debris, resulting from Construction operations under Contractor's control.
- F. Should the Work involve flammable or combustible liquids, Contractor shall be responsible for removing and disposing of same from project site.

1.04 FINAL CLEANING

- A. Immediately prior to the inspection for substantial completion of the Work, the Contractor shall:
 - 1. Remove Contractor's waste materials and rubbish from the site.
 - 2. Remove all bafflers and other protective devices.
 - 3. Thoroughly clean site to leave it in a rake clean condition, ready for use by Owner.

- B. Immediately prior to the final inspection for completion of the project, Contractor shall:
1. Execute final cleaning prior to final inspection.
 2. Prior to final completion, conduct an inspection of all work areas to verify that the entire work is clean.
 3. Maintain work in a clean condition until the Owner determines the Work and the Project are complete.
 4. Promptly remove from the vicinity of the completed work, all rubbish, unused materials, concrete forms, construction equipment, and temporary structures and facilities used during construction.
- C. Final acceptance of the Work by Owner will be withheld until Contractor has satisfactorily complied with the foregoing requirements for final cleanup of the Project site.

PART 2 PRODUCTS

Not Used.

PART 3 EXECUTION

Not Used.

END OF SECTION

SECTION 01730

OPERATION AND MAINTENANCE DATA

PART 1 GENERAL

1.01 DESCRIPTION

- A. Compile product data and related information appropriate for Owner's maintenance and operation of products furnished under the Contract
- B. Prepare operation and maintenance data as specified in this section and as referenced in other pertinent sections.
- C. Instruct Owner's personnel in the maintenance of products and in the operation of equipment and systems.
- D. Deliver all transmittals to The Owner.
- E. Use two copies of the Exhibit A at the end of this section to transmit each Operation and Maintenance Manual submittal.

1.02 SUBMITTALS

- A. Prepare data in the form of an instructional manual for use by Owner's personnel.
- B. Format:
 - 1. Size: 8-1/2-inch by 11-inch.
 - 2. Paper 20 lb. minimum, white, for typed pages.
 - 3. Text: Manufacturer's printed data, or neatly typewritten.
 - 4. Drawings.
 - a. Provide reinforced punched binder tab, bind in with text.
 - b. Reduced to 6-1/2-inch by 11-inch or 11-inch by 17-inch and folded to 6-1/2-inch by 11-inch.
 - c. Where reduction is impractical, folded and placed in 6-1/2-inch by 11-inch envelopes bound in text.
 - d. Suitably identified on drawings and envelopes.
 - 5. Provide fly-leaf for each separate product, or each piece of operating equipment.
 - a. Provide typed description of product, and major component parts of equipment.
 - b. Provide indexed tabs.
 - 6. Cover: Identify each volume with typed or printed title "OPERATION AND MAINTENANCE INSTRUCTIONS." List:
 - a. Title of Project.

- b. Identity of separate structure as applicable.
- c. Identity of general subject matter covered in manual.

7. As much as possible, assemble and bind material in the same order as specified.

C. Binders:

- 1. Preliminary manuals: Heavy paper covers.
- 2. Final manuals: Commercial quality substantial, permanent, 3-ring or 3-post binder with durable, cleanable plastic covers.

1.03 QUALITY ASSURANCE

A. Preparation of data shall be done by personnel:

- 1. Trained and experienced in maintenance and operation of the described products.
- 2. Completely familiar with requirements of this section.
- 3. Skilled as a technical writer to the extent required to communicate essential data.
- 4. Skilled as a draftsman competent to prepare required drawings.

B. Manuals for equipment and systems shall be prepared by the equipment manufacturer or system supplier.

1.04 CONTENT OF MANUALS

A. Neatly typewritten table of contents for each volume, arranged in a systematic order:

- 1. Contractor, name of responsible principal, address and telephone number.
- 2. A list of each product required to be included, indexed to the content of the volume.
- 3. List, with each product, the name, address and telephone number of:
 - a. Subcontractor or installer.
 - b. Maintenance contractor, as appropriate.
 - c. Identify the area of responsibility of each.
 - d. Local source of supply for parts and replacement.
- 4. Identify each product by product name and other identifying symbols as set forth in Contract Documents.

B. Product Data:

- 1. Include only those sheets, which are pertinent to the specific product.
- 2. Annotate each sheet to:
 - a. Clearly identify the specific product or part installed.
 - b. Clearly identify the data applicable to the installation.

- c. Delete references to inapplicable information.
- C. Drawings:
 - 1. Supplement product data with drawings as necessary to clearly illustrate:
 - a. Relations of component parts of equipment and systems.
 - 2. Coordinate drawings with information in Project Record Documents to assure correct illustration of completed installation.
 - 3. Do not use Project Record Documents as maintenance drawings.
- D. Written text, as required to supplement product data for the particular installation.
 - 1. Organize in a consistent format under separate headings for different procedures.
 - 2. Provide a logical sequence of instructions for each procedure.
- E. Copy of each Warranty, Bond and Service Contract Issued.
 - 1. Provide information sheet for Owner's personnel, give:
 - a. Proper procedures in the event of failure.
 - b. Instances, which might affect the validity of warranties or bonds.
- F. Completed Maintenance Record Data on Form Exhibit B.

1.05 MANUALS FOR EQUIPMENT AND SYSTEMS

- A. Provide an operation and maintenance manual for each item of equipment or system listed in the schedule of manuals in the quantity listed in the submittal schedule.
- B. Content, for each unit of equipment and system, as appropriate.
 - 1. Description of unit and component parts.
 - a. Function, normal operating characteristics, and limiting conditions.
 - b. Engineering data and tests.
 - c. Complete nomenclature and commercial number of all replaceable parts.
 - 2. Operating procedures.
 - a. Start-up, break-in, routine and normal operating instructions.
 - b. Regulation, control, stopping, shutdown and emergency instructions.
 - c. Summer and winter operating instructions, as applicable.
 - d. Special operating instructions.
 - 3. Maintenance procedures.
 - a. Routing operations.
 - b. Guide to "trouble-shooting."

- c. Disassembly, repair and reassembly.
 - d. Alignment adjusting and checking.
 - 4. Servicing and lubricating schedule.
 - a. Use of lubricants required.
 - 5. Manufacturer's printed operating and maintenance instructions.
 - 6. Description of sequence of operation by control manufacturer.
 - 7. Original manufacturer's parts list, illustrations, assembly drawings and diagrams required for maintenance.
 - a. Predicted life of parts subject to wear.
 - b. Items recommended to be stocked as spare parts.
 - 8. Each contractor's coordination drawings.
 - a. As-installed color-coded piping diagrams.
 - 9. Charts of valve tag numbers, with the location and function of each valve.
 - 10. List of original manufacturer's spare parts, manufacturer's current prices, and recommended quantities to be maintained in storage.
 - 11. Other data as required under pertinent sections of specifications.
- C. Prepare and include additional data when the need for such data becomes apparent during instruction of Owner's personnel.
- D. Additional Requirements for Operating and Maintenance are given in the detailed equipment specifications.

1.06 SUBMITTAL SCHEDULE

- A. Manuals for Equipment and Systems:
- 1. Submit three preliminary copies prior to the date of shipment of the equipment or system.
 - a. The Owner will review.
 - b. If acceptable, one copy will be returned to Contractor, one copy sent to Resident Project Representative and one copy retained in Owner's File.
 - c. If unacceptable, two copies will be returned to Contractor with Owner's comments for revision and one copy retained in Owner's file. Resubmit three revised preliminary copies for Owner's review.
 - d. No partial payments will be made for equipment and systems on hand or installed until preliminary manuals are submitted.
 - 2. Submit six final copies no less than 30 days prior to putting the equipment or system in service. If final manuals differ from accepted preliminary manuals, submit two copies of any necessary supplemental material, with instructions for insertion, for conforming

Owner's and resident Project Representative's copies of preliminary manuals to final manuals.

- a. The Owner will compare with accepted preliminary manual.
- b. If identical, or otherwise acceptable, Contractor will be so notified. One copy will be transmitted to Owner, five copies will be held for later transmittal to the Owner.
- c. If not acceptable, all six copies will be returned to Contractor for revision or retained by the Owner and the necessary revision data requested from Contractor, at the Owner's option.
- d. No portion of the Work is substantially complete until final equipment and system manuals relating to that portion of the Work are accepted by The Owner.
- e. Submit eight copies of any revisions found desirable during instruction of Owner's personnel, with instructions for insertion, for revising the Owner's and Resident Project Representatives copies of manual.

1.07 INSTRUCTION OF OWNER'S PERSONNEL

- A. Prior to final inspection or acceptance, fully instruct the Owner's designated operating and maintenance personnel in the start-up, operation, adjustment and maintenance of all products, equipment and Systems.
- B. Operation and Maintenance Manual shall constitute the basis of instruction:
 1. Review contents of manual with personnel in full detail to explain all aspects of operations and maintenance.
- C. Additional requirements for specialized instruction of Owner's personnel are given in the detailed equipment specifications.

1.08 SCHEDULES

- A. Equipment and Systems Operation and Maintenance Manuals shall be prepared for each of the following.

Type of Equipment
or System
Valves (including motor-operators)
Pressure Transmitter
Pressure Reducing/Sustaining Valve
Magnetic Flowmeter
Backflow Preventers
Agricultural Sprinkler Irrigation Systems

END OF SECTION

EXHIBIT "A"

O & M MANUAL. TRANSMITTAL NO. _____ Date Received: _____
Checked By: _____
Log Page: _____

Project: _____
Location: _____
Contractor: _____ Engineer: _____

Date Transmitted: _____ Specification Division: _____

Number Copies	Drawing or Description of Item	Manufacturer	Data Number

Remarks: _____

This Operation and Maintenance Manual submittal is deficient in the following areas:

- Equipment Record Sheets
- Organization (index & tabbing)
- Assembly, Disassembly, Installation, Alignment, Adjustment & Checkout Instruction
- Operating Instruction
- Lubrication & Maintenance Instructions
- Troubleshooting Guide
- Parts List & Ordering Instructions
- Schematics Specific to Installation Outline, Cross Section & Assembly
- Test Date
- Tag or Equipment Identification Numbers
- Others - See Remarks

Remarks: _____
_ Acceptable (provide five additional copies)
_ Not Acceptable - resubmit

By: _____
Date: _____

DISTRIBUTION: CONTRACTOR () PROJECT FILE () FIELD () OWNER () SECTION

SECTION 01740

WARRANTIES

PART 1 GENERAL

1.01 SECTION INCLUDES

- A. Contractor's One Year warranty.
- B. Product and Service Warranties.
- C. Preparation and submittal.
- D. Time and schedule of submittals.

1.02 CONTRACTOR'S ONE YEAR WARRANTY

- A. Unless otherwise provided, materials and equipment incorporated into Work shall be new and, where not specified, of the most suitable grade of the respective kinds, for the intended use, and workmanship shall be in accordance with construction practices acceptable to Owner.
- B. Unless otherwise provided, warrant equipment, materials, and labor furnished or performed under this Contract against defects in design, materials and workmanship (unless furnished by Owner), for a period of twelve months (unless longer guarantees or warranties are provided for elsewhere in Construction Documents in which case the longer guarantees or warranties shall prevail) after final acceptance, regardless of whether furnished or performed by Contractor or subcontractors of any tier.
 - 1. Upon receipt of written notice from Owner of any defect in equipment, materials, or labor during the applicable warranty period, due to defective design, materials or workmanship, the affected items or parts thereof shall be redesigned, repaired or replaced by Contractor at a time acceptable to Owner.
- C. Perform tests Owner may require to verify that redesign, repairs and replacements comply with requirements of Contract.
 - 1. Costs incidental to such redesign, repair, replacement and testing, including the removal, necessary to gain access, shall be borne by Contractor.
- D. Warrant redesigned, repaired or replaced work against defective design, materials and workmanship for a period of twelve months from and after date of acceptance thereof.
 - 1. Should Contractor fail to promptly make the necessary redesign, repair, replacement and test, Owner may perform or cause to be performed the same at Contractor's expense.
 - 2. Contractor and its surety or sureties shall be liable for the satisfaction and run performance of the warranties as set forth herein.